



PRO – 1250 SERIES

DIN rail three phase four wire energy meter

1.1	Safety instruction
1.2	Foreword
1.3	Performance criteria
1.4	Specifications
1.5	Basic errors
1.6	Description
1.7	Dimensions
1.8	Installation
1.9	Operating
1.10	Troubleshooting
1.11	Technical support

User manual



1.1 Safety instructions

Information for Your Own Safety

This manual does not contain all of the safety measures for operation of the equipment (module, device), because special operating conditions, and local code requirements or regulations may necessitate further measures. However, it does contain information which must be read for your personal safety and to avoid material damages. This information is highlighted by a warning triangle and is represented as follows, depending on the degree of potential danger.



Warning

This means that failure to observe the instruction can result in death, serious injury or considerable material damage.



Caution

This means hazard of electric shock and failure to take the necessary safety precautions will result in death, serious injury or considerable material damage.

Qualified personnel

Commissioning and operation of the equipment (module, device) described in this manual may only be performed by qualified personnel. Qualified personnel in the sense of the safety information contained in this manual are persons who are authorized to commission, start up, ground and label devices, systems and circuits according to safety and Regulatory standards.

Use for the intended purpose

The equipment (device, module) may only be used for the application cases specified in the catalogue and the user manual and only in connection with devices and components recommended and approved by DMMetering.

Proper handling

The prerequisites for perfect, reliable operation of the product are proper transport, proper storage, installation and assembly, as well as proper operation and maintenance. When operating electrical equipment, certain parts of this equipment automatically carry dangerous voltages. Improper handling can therefore result in serious injuries or material damage.

- ? Use only isolated tools.
- ? Do not connect while circuit is live (hot).
- ? Place the meter only in dry surroundings.
- ? Do not mount the meter in an explosive area or expose the meter to dust, mildew and insects.
- ? Make sure the used wires are suitable for the maximum current of this meter.
- ? Make sure the AC wires are connected correctly before activating the current/voltage to the meter.
- ? Do not touch the meter connecting clamps directly with your bare hands, with metal, blank wire or other material as you will have the chance of an electrical shock.
- ? Make sure the protection cover is placed after installation.

- ? Installation, maintenance and reparation should only be done by qualified personnel.
- ? Never break the seals and open the front cover as this might influence the functionality of the meter, and will avoid any warranty.
- ? Do not drop, or allow physical impact to the meter as there are high precision components inside that may break.

Exclusion of liability

We have checked the contents of this publication and every effort has been made to ensure that the descriptions are as accurate as possible.

However, deviations from the description cannot be completely ruled out, so that no liability can be accepted for any errors contained in the information given. The data in this manual is checked regularly and the necessary corrections are included in subsequent editions. We are grateful for any improvements that you care to suggest.

Subject to technical modifications without notice.

Copyright

Copyright DMMetering November 2007 All rights Reserved.

It is prohibited to pass on or copy this document or to use or disclose its contents without our express permission. Any duplication is a violation of the law and subject to criminal and civil penalties. All rights reserved, particularly in the event of a patent award or utility model registration.

Registered trademarks

DMMetering® is registered trademark of Inepro Industries Ltd – member of the Inepro Group. The other names appearing in this manual may be trade names the use of these names by third parties for their own purposes may infringe the rights of the owners.

1.2 Foreword

Thank you for purchasing the DMMetering PRO1250 SERIES DIN rail three phase four wire energy meter. The DMMetering PRO1250 SERIES energy meter is the most advanced type electronic kWh meter available at the market. With the DMMetering product range we have introduced a large scale of energy meters on the market suitable for 110V AC to 400V AC (50 or 60Hz). Besides the normal energy meters we also developed our own pre-paid meters with chip card, chip card re-loaders and a complete PC management control system. For more information on other product please contact our sales department at sales@dmmetering.com or info@inepro.com.hk.

Although we produce the DMMetering PRO 1250 SERIES meter according to IEC 62053-21 and our quality inspection is very accurate there might always be a possibility that your product shows a fault or failure for which we do apologize. Under normal conditions your product should give you years of benefit and pleasure. In case there is a problem with the energy meter you should contact your dealer immediately. All energy meters are sealed with a special seal. Once this seal is broken there is no possibility to claim for warranty. Therefore NEVER open an energy meter or break the seal of the energy meter. The warranty time is 5 years, after production, and only valid for construction faults.

1.3 Performance criteria:

Operating humidity	= 75%
Storage humidity	= 95%
Operating temperature	-10°C - +50°C
Storage temperature	-30°C - +70°C
International standard	IEC 62053-21
Accuracy class	1
Protection against penetration of dust and water	IP51
Insulating encased meter of protective class	?

1.4 Specifications:

Meter type	PRO-1250A (register display) PRO-1250D (LCD display)
Nominal voltage (Un)	230/400V AC (3~)
Operational voltage	161/279 – 300/520V AC (3~)
Insulation capabilities:	
- AC voltage withstand	2KV for 1 minute
- Impulse voltage withstand	6KV – 1.2μS waveform
Basic current (Ib)	
CT version	1A
Direct version	10A
Maximum rated current (Imax)	
CT version	5A
Direct version	100A
Operational current range	0.4% Ib- Imax
Over current withstand	30Imax for 0.01s
Operational frequency range	50Hz ±10%
Internal power consumption	=2W / 10VA per phase
Test output flash rate (PULSE LED)	
CT version	1600imp/kWh
Direct version	400imp/kWh
Test pulse output rate (pins 8 & 9)	
CT version	1600imp/kWh
Direct version	400imp/kWh
L1, L2, L3 LED indicators	Meter is connected to power
Consumption indicator (Red LED)	Flashing at load running

1.5 Basic errors:

With balanced loads

0.05Ib	Cosφ = 1	±1.5%
0.1Ib	Cosφ = 0.5L	±1.5%
	Cosφ = 0.8C	±1.5%
0.1Ib - Imax	Cosφ = 1	±1.0%
0.2Ib - Imax	Cosφ = 0.5L	±1.0%
	Cosφ = 0.8C	±1.0%

With single phase load

0.1lb - lmax	Cosf = 1	±2.0%
0.2lb - lmax	Cosf = 0.5L	±2.0%

1.6 Description

A	Front panel
B	Cover
C	Base
D	Security hasp

Material

Front panel	PC inflammable retarding
Cover	ABS inflammable retarding
Base	ABS inflammable retarding

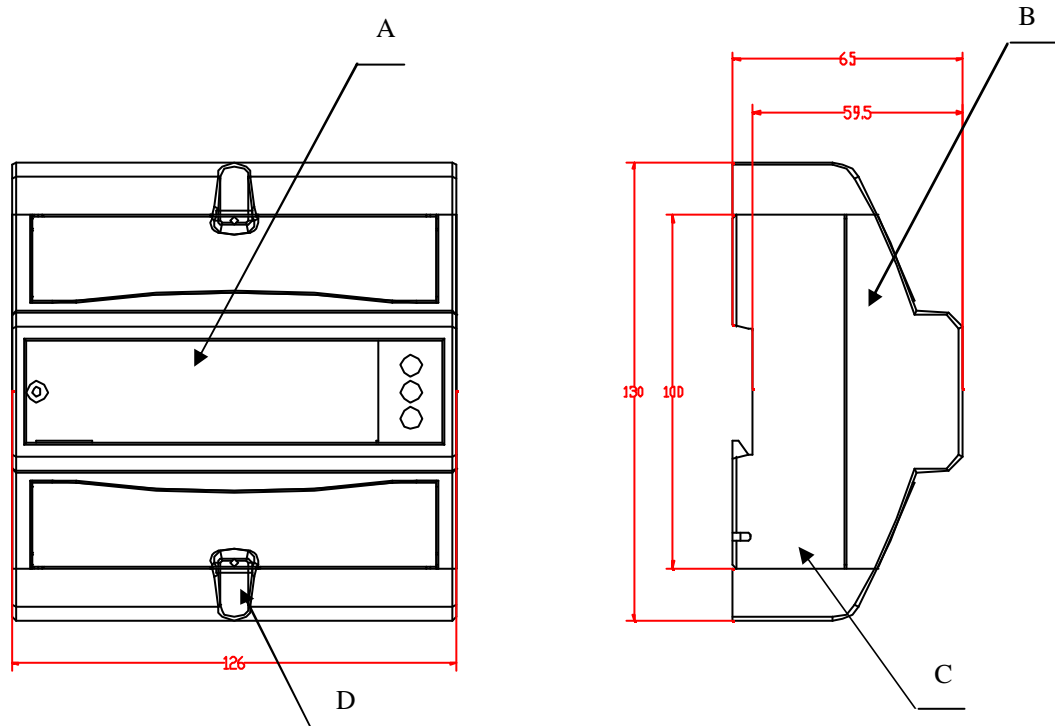

1.7 Dimensions

Height	130 mm
Width	126 mm
Depth	65 mm
Weight	0.7 Kg (net)

1.8 Installation

CAUTION

- ? Turn off and lock out all power supplying the energy meter and the equipment to which it is installed before working on it.
- ? Always use a properly rated voltage sensing device to confirm that power is off.

WARNING

- ? Installation should be performed by qualified personnel familiar with applicable codes and regulations.
- ? Use isolated tools to install the meter.
- ? Fuse or thermal cut-off or single-pole circuit breaker can't be fitted on the supply line and not the neutral line.

- We recommend that the connecting wire which is used to connect the meter to the outside circuit should be sized according to local codes and regulations for the ampacity of the circuit breaker or over current device used in the circuit.
- An external switch or a circuit-breaker should be installed on the inlet wire, which will be used as a disconnection device for the meter. And there it is recommended that the switch or circuit-breaker is near the meter so that it is more convenience for the operator. The switch or circuit-breaker should comply with the specifications of the buildings electrical design and all local regulations.
- An external fuse or thermal cut-off which will be used as an over current protection device for the meter must be installed on the supply side wire, and it is recommended that the over current protection device is near the meter so that it is more convenience for the operator. The over current protection device should comply with the specifications of the buildings electrical design and all local regulations.
- This meter can be installed indoor directly, or in a meter box which is waterproof outdoor, subject to local codes and regulations.
- To prevent tampering, secure the meter with a padlock or a similar device.
- The meter has to be installed against a wall which is fire resistant.
- The meter has to be installed in a good ventilated and dry place.
- The meter has to be installed in a protection box when placed in dangerous or dusty environment.
- The meter can be installed and used after being tested and sealed with a letter press printing.
- The meter can be installed on a 35mm DIN rail or direct on a meter board with screws.
- The meter should be installed in an available height so that it is easy to read.
- When the meter is installed in an area with frequent surges due to e.g. thunderstorms, welding machines, inverters etc, protect the meter with Surge Protection Devices
- After finishing installation, the meter must be sealed to prevent tampering.
- Connection of the wires should be done in accordance with the underneath connection diagram

A. Direct series

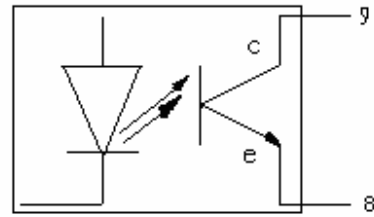
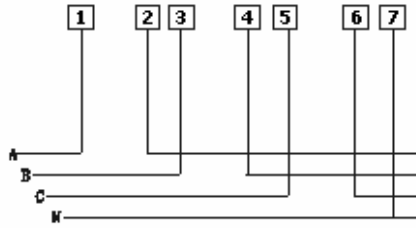

- 1/2 Ia IN/OUT
- 3/4 Ib IN/OUT
- 5/6 Ic IN/OUT
- 7 Neutral

- 8 and 9 Test pulse output contact

B. CT series

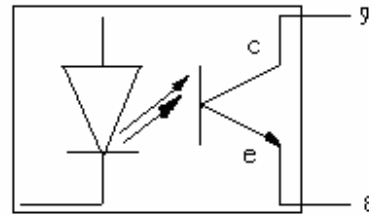
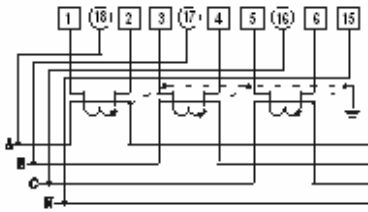

- 1/2 Ia IN/OUT
- 3/4 Ib IN/OUT
- 5/6 Ic IN/OUT
- 18/17/16 Phase A/B/C
- 15 Neutral

- 8 and 9 Test pulse output contact

1.9 Operating

Consumption indication

On the PRO-1250 SERIES'S front panel, there are four LED, in which three LED are for three phase voltage and another one for impulse.

Reading the meter

The PRO-1250A series energy meter is equipped with a 5+1 register. Five integers are marked with black color and one decimal is marked with red. The PRO-1250D series energy meter is equipped with 5+2 LCD display which is used as recording consumption and can't be reset to zero. The reading accuracy is 1/100 kWh.

Pulse output

PRO-1250 series DIN rail energy meter is equipped with a pulse output which is fully separated from the inside circuit. That generates pulses in proportion to the measured energy. They are test pulse output (pins 8 & 9). Usually, the test pulse output is used as testing accuracy or reading purpose in close quarters.

The test pulse output is a polarity dependant, passive transistor output requiring an

external voltage source for correct operation. For this external voltage source, the voltage (U_i) should be 5-27V DC, and the maximum input current (I_{imax}) should be 27mA DC. To connect the impulse output, connect 5-27V DC to connector 9 (anode), and the signal wire (S) to connector 8 (cathode).

1.10 Troubleshooting

CAUTION

- ? During reparation and maintenance, do not touch the meters connecting clamps directly with your bare hands, with metal, blank wire or other material as you will have the chance of an electricity shock and a possible chance for health damage.
- ? Turn off and lock out all power supplying the energy meter and the equipment to which it is installed before opening the protection cover to prevent the hazard of an electric shock.

WARNING

- ? Maintenance or reparation should be performed by qualified personnel familiar with applicable codes and regulations.
- ? Use insulated tools to maintain or repair the meter.
- ? Make sure the protection cover is in place after maintenance or reparation.

Problem	Check	Solution
No light for the Power supply indicator (L1, L2 & L3 LED).	Is AC power supply connected to the meter ?	Check switch or circuit-breaker and fuse or thermal cut-off.
	Is the L1, L2, L3 and N connecting correct ?	Re-install terminal screws on the L1, L2, L3 and N. Make sure all screws are fixed. Then there should be a 230V 50Hz AC voltage between the terminal screws on the N and L1 or L2 or L3, when power supply is input.
	Are the terminals 1, 2, 3, 4, 5, 6 and 7 connecting correct ?	Reinstall terminal screws on the 1, 2, 3, 4, 5, 6 and 7. Make sure all screws are fixed. Then there should be a 230V 50Hz AC voltage between the terminal screws on the 7 and 1 or 3 or 5, when power supply is input.
	Maybe there is a fault in the inside circuit.	Please contact your technical supporter to replace this meter.
No light for the consumption indicator (PULSE LED).	Is the load running ?	Only when load is running, this LED will flash.
	Is the operating power too low ?	If the operating power is too low, the spacing interval of the flashes will take some more time this is why it seems like LED is not burning
	Maybe there is a fault in the inside circuit.	Please contact your technical supporter to replace this meter.

Continue.

Problem	Check	Solution
The register can't run.	<p>Is there a power supply inside the meter ?</p> <p>Is the operating power too low ?</p> <p>Maybe there is a fault in the inside circuit.</p>	<p>Check that the power supply indicator (L1, L2 & L3 LED) is burning.</p> <p>If the operating power is too low, the spacing interval of the pulses will take some more time this is why it seems like the meter won't count</p> <p>Please contact your technical supporter to replace this meter.</p>
No test pulse output.	<p>Is DC power supply connected to the meter ?</p> <p>Is the connecting correct ?</p> <p>Maybe there is a fault in the inside circuit.</p>	<p>Check the external voltage source (Ui) is 5-27V DC.</p> <p>Check correct connecting: connect 5-27V DC to connector 9 (anode), and the signal wire (S) to connector 8 (cathode).</p> <p>Please contact your technical supporter to replace this meter.</p>
Pulse output rate wrong.	<p>Maybe there is a fault in the inside circuit.</p>	<p>Please contact your technical supporter to replace this meter.</p>

1.11 Technical support

For questions about one of our products, please contact:

- DMMetering dealer in your in your region
- Your local DMMetering distributor
- Email: support@dmmetering.com

www.dmmetering.com

Inepro Industries Ltd.
Room 2303, Office Tower
1 Harbour Road, Wan Chai
Hong Kong
Fax: +852 2911 1200
www.inepro.com.hk
info@inepro.com.hk

