

A42

Single phase meter

6A, 4 DIN with IR port

2



A42

2CMC481003C0201

Description

Transformer connected (CTVT) electricity meter. Verified and approved according to MID. IEC approval. Instrument values. Alarm function. Communication - Infrared (M-Bus). Optional - Communication with M-Bus, RS-485 Modbus, RS-485 EQ bus.

Ordering details

Voltage V	Accuracy Class	I/O	Communication	Type	Order Code	Pkg qty	Weight 1 pc
Steel							
Active energy							
57.7...288 V AC	Class B (Cl. 1)	Pulse output	-	A42 111 - 100	2CMA170555R1000	1	0.20
			RS-485	A42 112 - 100	2CMA170510R1000	1	0.20
			M-Bus	A42 113 - 100	2CMA100242R1000	1	0.20
Bronze							
Active and reactive energy, import/export.							
57.7...288 V AC	Class B (Cl. 1) Reactive Cl. 2	Pulse output	RS-485	A42 212 - 100	2CMA170511R1000	1	0.20
Silver							
Active and reactive energy, import/export, tariffs 1-4, tariff control via inputs and communication.							
57.7...288 V AC	Class B (Cl. 1) Reactive Cl. 2	2 output, 2 input	RS-485	A42 312 - 100	2CMA170512R1000	1	0.20
Gold							
Active and reactive energy, import/export, tariffs 1-4, tariff controlled via inputs, communication or clock, previous values, max and min demand.							
57.7...288 V AC	Class B (Cl. 1) Reactive Cl. 2	2 output, 2 input	RS-485	A42 412 - 100	2CMA170513R1000	1	0.20
			M-Bus	A42 413 - 100	2CMA170514R1000	1	0.20
Platinum							
Active and reactive energy, import/export, tariffs 1-4, tariff controlled via inputs, communication or clock, previous values, max and min demand, advanced load profiles, harmonics and THD.							
57.7...288 V AC	Class C (Cl. 0,5 S) Reactive Cl. 2	Configurable 4 I/O channels	RS-485	A42 552 - 100	2CMA100238R1000	1	0.20
			M-Bus	A42 553 - 100	2CMA170516R1000	1	0.20

Dimensions

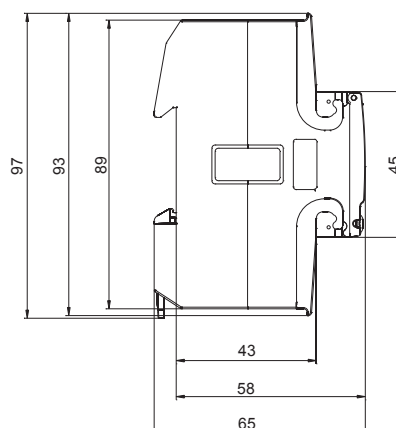
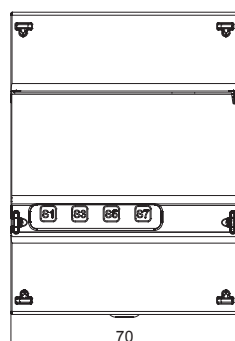

A series

Technical data

	A41	A42	A43	A44
Voltage/current inputs				
Nominal voltage	230 V AC		3x230/400 V AC	
Voltage range	57.7 - 288 V AC (-20% - +15%)		3x57.7/100 ... 288/500 V AC (-20% - +15%)	
Power dissipation voltage circuits	0.8 VA (0.8 W) total			
Power dissipation current circuits	0.007 VA (0.007 W) at 230 VAC	0.001 VA (0.001 W) at 230 VAC	0.007 VA (0.007 W) per phase at 230 VAC and I ₀	0.001 VA (0.001 W) per phase at 230 VAC and I ₀
Base current I _b	5 A	-	5 A	-
Rated current I _n	-	1 A	-	1 A
Reference current I _{ref}	5 A	-	5 A	-
Transitional current I _{tr}	0.5 A	0.05 A	0.5 A	0.05 A
Maximum current I _{max}	80 A	6 A	80 A	6 A
Minimum current I _{min}	0.25 A	0.02 A	0.25 A	0.01 A
Starting current I _{st}	< 20 mA	< 1 mA	< 20 mA	< 1 mA
Terminal wire area	1 - 25 mm ²	0.5 - 10 mm ²	1 - 25 mm ²	0.5 - 10 mm ²
Recommended tightening torque	3 Nm	1.5 Nm	3 Nm	1.5 Nm
Communication				
Terminal wire area	0.5 - 1 mm ²		0.5 - 1 mm ²	
Recommended tightening torque	0.25 Nm			
Transformer ratios				
Configurable voltage ratio (VT)	-	1/999 - 999999/1	-	1/999 - 999999/1
Configurable current ratio (CT)	-	1/9 - 9999/1	-	1/9 - 9999/1
Pulse indicator (LED)				
Pulse frequency	1000 imp/kWh	5000 imp/kWh	1000 imp/kWh	5000 imp/kWh
Pulse length	40 ms	40 ms	40 ms	40 ms
General data				
Frequency	50 or 60 Hz ± 5%			
Accuracy Class	B (Cl.1) or Reactive Cl. 2	B (Cl.1), C (Cl. 0.5 S) or Reactive Cl. 2	A (Cl.2), B (Cl.1) or Reactive Cl. 2	B (Cl.1), C (Cl. 0.5 S) or Reactive Cl. 2
Active energy	1%	0.5%, 1%	1%, 2%	0.5%, 1%
Display of energy	Pixel oriented			
Environmental				
Operating temperature	-40°C - +70°C			
Storage temperature	-40°C - +85°C			
Humidity	75% yearly average, 95% on 30 days/year			
Resistance to fire and heat	Terminal 960°C, cover 650°C (IEC 60695-2-1)			
Resistance to water and dust	IP20 on terminal block without protective enclosure and IP51 in protective enclosure, according to IEC 60529.			
Mechanical environment	Class M2 in accordance with the Measuring Instrument Directive (MID), (2004/22/EC).			
Electromagnetic environment	Class E2 in accordance with the Measuring Instrument Directive (MID), (2004/22/EC).			
Outputs				
Current	2 - 100 mA			
Voltage	5 - 240 V AC/DC. For meters with only 1 output, 5 - 40 V DC.			
Pulse output frequency	Programmable: 1 - 999999 imp/kWh			
Pulse length	Programmable: 10 - 990 ms			
Terminal wire area	0.5 - 1 mm ²			
Recommended tightening torque	0.25 Nm			
Inputs				
Voltage	0 - 240 V AC/DC			
OFF	0 - 12 V AC/DC			
ON	57-240 V AC/24 - 240 V DC			
Min. pulse length	30 ms			
Terminal wire area	0.5 - 1 mm ²			
Recommended tightening torque	0.25 Nm			
EMC compatibility				
Impulse voltage test	6 kV 1.2/50 μs (IEC 60060-1)			
Surge voltage test	4 kV 1.2/50 μs (IEC 61000-4-5)			
Fast transient burst test	4 kV (IEC 61000-4-4)			
Immunity to electromagnetic HF-fields	80 MHz - 2 GHz at 10 V/m (IEC 61000-4-3)			
Immunity to conducted disturbance	150 kHz - 80 MHz, (IEC 61000-4-6)			
Immunity to disturbance with harmonics	2kHz - 150kHz			
Radio frequency emission	EN 55022, class B (CISPR22)			
Electrostatic discharge	15 kV (IEC 61000-4-2)			
Standards	IEC 62052-11, IEC 62053-21 class 1 & 2, IEC 62053-22 class 0,5 S, IEC 62053-23 class 2, IEC 62054-21, GB/T 17215.211-2006, GB/T 17215.321-2008 class 1 & 2, GB/T 17215.322-2008 class 0,5 S, GB 4208-2008, EN 50470-1, EN 50470-3 category A, B & C			
Mechanical				
Material	Polycarbonate in transparent front glass, bottom case, upper case and terminal cover, Glass reinforced polycarbonate in terminal block.			
Dimensions				
Width	70 mm		123 mm	
Height	97 mm		97 mm	
Depth	65 mm		65 mm	
DIN modules	4		7	

¹ Only A44 552 - 110 and A44 553 - 110