

PowerLogic® Series 800 Power Meter PM810

63230-500-201A3

Reference manual

Retain for future use.



HAZARD CATEGORIES AND SPECIAL SYMBOLS

Read these instructions carefully and look at the equipment to become familiar with the device before trying to install, operate, service, or maintain it. The following special messages may appear throughout this bulletin or on the equipment to warn of potential hazards or to call attention to information that clarifies or simplifies a procedure.



The addition of either symbol to a “Danger” or “Warning” safety label indicates that an electrical hazard exists which will result in personal injury if the instructions are not followed.



This is the safety alert symbol. It is used to alert you to potential personal injury hazards. Obey all safety messages that follow this symbol to avoid possible injury or death.

DANGER

DANGER indicates an imminently hazardous situation which, if not avoided, will result in death or serious injury.

WARNING

WARNING indicates a potentially hazardous situation which, if not avoided, can result in death or serious injury.

CAUTION

CAUTION indicates a potentially hazardous situation which, if not avoided, can result in minor or moderate injury.

CAUTION

CAUTION, used without the safety alert symbol, indicates a potentially hazardous situation which, if not avoided, can result in property damage.

NOTE: Provides additional information to clarify or simplify a procedure.

PLEASE NOTE

Electrical equipment should be installed, operated, serviced, and maintained only by qualified personnel. No responsibility is assumed by Schneider Electric for any consequences arising out of the use of this material.

CLASS A FCC STATEMENT

This equipment has been tested and found to comply with the limits for a Class A digital device, pursuant to part 15 of the FCC Rules. These limits are designed to provide reasonable protection against harmful interference when the equipment is operated in a commercial environment. This equipment generates, uses, and can radiate radio frequency energy and, if not installed and used in accordance with the instruction manual, may cause harmful interference to radio communications. Operation of this equipment in a residential area is likely to cause harmful interference in which case the user will be required to correct the interference at his own expense. This Class A digital apparatus complies with Canadian ICES-003.

CHAPTER 1—INTRODUCTION	1
About This Manual	1
Topics Not Covered in This Manual	2
What is the Power Meter?	3
Power Meter Hardware	4
Power Meter With Integrated Display	4
Power Meter Without Display	5
Power Meter With Remote Display	6
Power Meter Parts and Accessories	7
Box Contents	8
Features	9
Firmware	10
CHAPTER 2—SAFETY PRECAUTIONS	11
CHAPTER 3—OPERATION	13
Operating the Display	13
How the Buttons Work	14
Changing Values	14
Menu Overview	14
Set Up the Power Meter	16
Power Meter With Integrated Display Communications Setup	17
Power Meter With Remote Display Communications Setup	18
Comm1 Setup	18
Comm2 Setup	18
Set Up the Date	19
Set Up the Time	19
Set Up the Language	20
Set Up CTs	20
Set Up PTs	21
Set Up Frequency	21
Set Up the Meter System Type	22
Set Up Alarms	23
Set Up I/Os	24
Set Up the Passwords	25
Set Up the Operating Time Threshold	25
Advanced Power Meter Setup Options	26
Set Up the Phase Rotation	26
Set Up the Incremental Energy Interval	27
Set Up the THD Calculation	27
Set Up the VAR/PF Convention	28
Set Up the Lock Resets	28
Set Up the Alarm Backlight	29
Set Up the Bar Graph	29
Set Up the Power Demand Configuration	30
Power Meter Resets	31
Initialize the Power Meter	31
Reset the Accumulated Energy Readings	32

Reset the Accumulated Demand Readings	32
Reset the Minimum/Maximum Values	33
Change the Mode	33
Reset the Accumulated Operating Time	34
Power Meter Diagnostics	35
View the Meter Information	35
Check the Health Status	36
Read and Write Registers	36
View the Meter Date and Time	37
CHAPTER 4—METERING CAPABILITIES	39
Real-Time Readings	39
Min/Max Values for Real-time Readings	40
Power Factor Min/Max Conventions	42
Power Factor Sign Conventions	43
Demand Readings	44
Demand Power Calculation Methods	45
Block Interval Demand	45
Synchronized Demand	47
Thermal Demand	48
Demand Current	48
Predicted Demand	48
Peak Demand	49
Generic Demand	50
Input Metering Demand	51
Energy Readings	53
Energy-Per-Shift (PM810 with PM810LOG)	56
Configuration	56
Power Analysis Values	58
CHAPTER 5—INPUT/OUTPUT CAPABILITIES	61
Digital Inputs	61
Demand Synch Pulse Input	63
Relay Output Operating Modes	64
Solid-state KY Pulse Output	68
2-wire Pulse Initiator	68
Calculating the Kilowatt-hour-Per-Pulse Value	69
Analog Inputs	70
Analog Outputs	71
CHAPTER 6—ALARMS	73
About Alarms	73
Alarm Groups	74
Setpoint-driven Alarms	75
Priorities	77
Viewing Alarm Activity and History	77
Types of Setpoint-controlled Functions	78
Scale Factors	81
Scaling Alarm Setpoints	83

Alarm Conditions and Alarm Numbers	83
CHAPTER 7—LOGGING	89
Introduction	89
Memory Allocation for Log Files	90
Alarm Log	91
Alarm Log Storage	91
Maintenance Log	91
Data Logs	93
Alarm-driven Data Log Entries	95
Billing Log	95
Configure the Billing Log Logging Interval	96
CHAPTER 8—MAINTENANCE AND TROUBLESHOOTING	99
Introduction	99
Power Meter Memory	100
Date and Time Settings	100
Identifying the Firmware Version, Model, and Serial Number	100
Viewing the Display in Different Languages	101
Technical Support	101
Troubleshooting	102
Heartbeat LED	103
APPENDIX A—POWER METER REGISTER LIST	105
About Registers	105
Floating-point Registers	105
How Power Factor is Stored in the Register	106
How Date and Time are Stored in Registers	107
Register List	108
APPENDIX B—USING THE COMMAND INTERFACE	179
Overview of the Command Interface	179
Issuing Commands	181
I/O Point Numbers	185
Operating Outputs from the Command Interface	186
Using the Command Interface to Change Configuration Registers	187
Conditional Energy	188
Command Interface Control	188
Digital Input Control	189
Incremental Energy	189
Using Incremental Energy	190
Setting Up Individual Harmonic Calculations	192
Changing Scale Factors	193
Enabling Floating-point Registers	194
APPENDIX C—GLOSSARY	195
Terms	195
Abbreviations and Symbols	198
INDEX	201

ENGLISH

CHAPTER 1—INTRODUCTION

About This Manual

This reference manual explains how to operate and configure a PowerLogic® Series 800 Power Meter PM810. Unless otherwise noted, the information contained in this manual refers to the following Power Meters:

- Power Meter with integrated display
- Power Meter without a display
- Power Meter with a remote display.

Refer to “Power Meter Parts and Accessories” on page 7 for all models and model numbers. For a list of supported features, see “Features” on page 9.

NOTE: The Power Meter units on the PM810, PM810U, and the PM810RD are functionally equivalent.

Topics Not Covered in This Manual

Some of the power meter's advanced features, such as onboard data logs and alarm log files, can only be set up over the communications link using System Manager™ Software (SMS) from PowerLogic. This power meter instruction bulletin describes these advanced features, but does not explain how to set them up. For instructions on using SMS, refer to the SMS online help and the SMS setup guide, which is available in English, French, and Spanish. See Table 1–1 for a list of power meter models supported by SMS.

Table 1–1: Power Meter Models Supported By SMS

SMS Type	SMS Version	PM810	PM810 with PM810LOG
SMS121	3.3.2.2 or higher	✓	✓
SMS1500	3.3.2.2 or higher	✓	✓
SMS3000	3.3.2.2 or higher	✓	✓
SMSDL	4.0 or higher	✓	✓
SMSSE	4.0 or higher	✓	✓
SMSPE	4.0 or higher	✓	✓

What is the Power Meter?

The power meter is a multifunction, digital instrumentation, data acquisition and control device. It can replace a variety of meters, relays, transducers and other components. The power meter can be installed at multiple locations within a facility.

The power meter is equipped with RS485 communications for integration into any power monitoring and control system. However, System Manager™ software (SMS) from PowerLogic, which is written specifically for power monitoring and control, best supports the power meter’s advanced features.

The power meter is a true rms meter capable of exceptionally accurate measurement of highly nonlinear loads. A sophisticated sampling technique enables accurate, true rms measurement through the 63rd harmonic. You can view over 50 metered values plus minimum and maximum data from the display or remotely using software. Table 1–2 summarizes the readings available from the power meter.

Table 1–2: Summary of power meter Instrumentation

Real-time Readings	Power Analysis
<ul style="list-style-type: none"> • Current (per phase, residual, 3-Phase) • Voltage (L–L, L–N, 3-Phase) • Real Power (per phase, 3-Phase) • Reactive Power (per phase, 3-Phase) • Apparent Power (per phase, 3-Phase) • Power Factor (per phase, 3-Phase) • Frequency • THD (current and voltage) 	<ul style="list-style-type: none"> • Displacement Power Factor (per phase, 3-Phase) • Fundamental Voltages (per phase) • Fundamental Currents (per phase) • Fundamental Real Power (per phase) • Fundamental Reactive Power (per phase) • Unbalance (current and voltage) • Phase Rotation • Current and Voltage Harmonic Magnitudes & Angles (per phase)^① • Sequence Components
Energy Readings	Demand Readings
<ul style="list-style-type: none"> • Accumulated Energy, Real • Accumulated Energy, Reactive • Accumulated Energy, Apparent • Bidirectional Readings • Reactive Energy by Quadrant • Incremental Energy • Conditional Energy 	<ul style="list-style-type: none"> • Demand Current (per phase present, 3-Phase avg.) • Average Power Factor (3-Phase total) • Demand Real Power (per phase present, peak) • Demand Reactive Power (per phase present, peak) • Demand Apparent Power (per phase present, peak) • Coincident Readings • Predicted Power Demands

① PM810 with PM810LOG up to the 31st harmonic

Power Meter Hardware

Power Meter With Integrated Display

Figure 1–1: Parts of the Series 800 Power Meter with integrated display

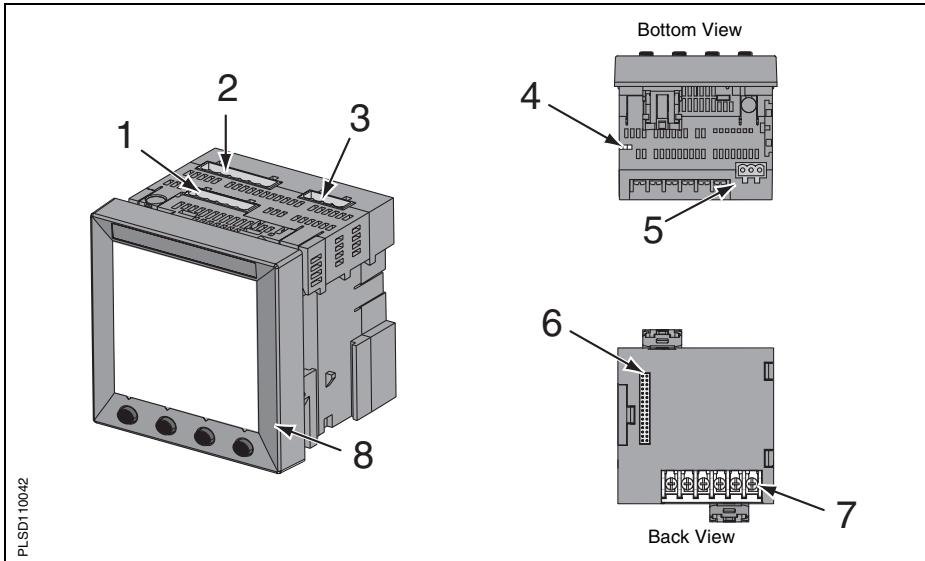

Table 1–3: Parts of the Series 800 Power Meter With Integrated Display

No.	Part	Description
1	Control power supply connector	Connection for control power to the power meter.
2	Voltage inputs	Voltage metering connections.
3	I/O connector	KY pulse output/digital input connections
4	Heartbeat LED	A green flashing LED indicates the power meter is ON.
5	RS-485 port (COM1)	The RS-485 port is used for communications with a monitoring and control system. This port can be daisy-chained to multiple devices.
6	Option module connector	Used to connect an option module to the power meter.
7	Current inputs	Current metering connections.
8	Integrated display	Visual interface to configure and operate the power meter.

Power Meter Without Display

Figure 1–2: Parts of the Series 800 Power Meter without display

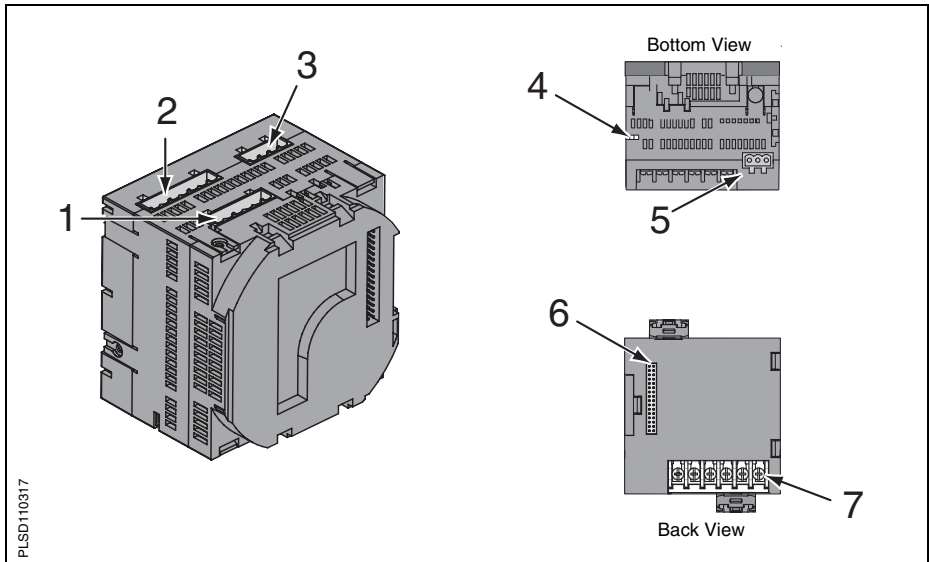

Table 1–4: Parts of the Series 800 Power Meter Without Display

No.	Part	Description
1	Control power supply connector	Connection for control power to the power meter.
2	Voltage inputs	Voltage metering connections.
3	I/O connector	KY pulse output/digital input connections
4	Heartbeat LED	A green flashing LED indicates the power meter is ON.
5	RS-485 port (COM1)	The RS-485 port is used for communications with a monitoring and control system. This port can be daisy-chained to multiple devices.
6	Option module connector	Used to connect an option module to the power meter.
7	Current inputs	Current metering connections.

Power Meter With Remote Display

NOTE: The remote display kit (PM8RD) is used with a power meter without a display. See “Power Meter Without Display” on page 5 for the parts of the power meter without a display.

Figure 1–3: Parts of the remote display and the remote display adapter

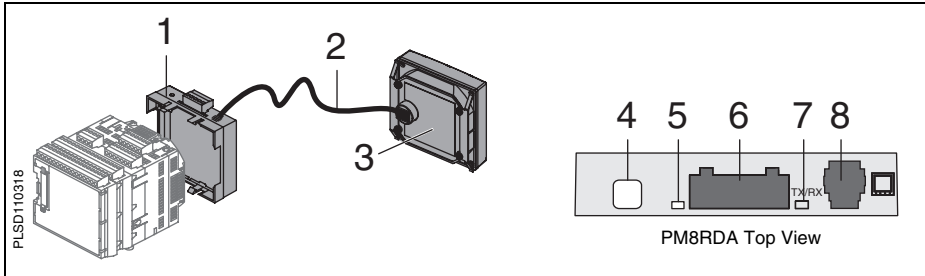







Table 1–5: Parts of the Remote Display

No.	Part	Description
1	Remote display adapter (PM8RDA)	Provides the connection between the remote display and the power meter. Also provides an additional RS232/RS485 connection (2- or 4-wire).
2	Cable CAB12	Connects the remote display to the remote display adapter.
3	Remote display (PM8D)	Visual interface to configure and operate the power meter.
4	Communications mode button	Use to select the communications mode (RS232 or RS485).
5	Communications mode LED	When lit the LED indicates the communications port is in RS232 mode.
6	RS232/RS485 port	The RS485 port is used for communications with a monitoring and control system. This port can be daisy-chained to multiple devices.
7	Tx/Rx Activity LED	The LED flashes to indicate communications activity.
8	CAB12 port	Port for the CAB12 cable used to connect the remote display to the remote display adapter.

Power Meter Parts and Accessories

Table 1–6: Power Meter Parts and Accessories

	Model Number	
	Square D	Merlin Gerin
Power Meters		
	PM810 ^①	PM810MG ^①
	PM810U ^①	PM810UMG ^①
	PM810RD ^①	PM810RDMG ^①
Accessories		
	PM8RD	PM8RDMG
	PM8RDA	
Input/Output Modules	PM8M22, PM8M26, PM8M2222	
PM810 Logging Module	PM810LOG	
Cable (12 inch) Extender Kit for displays	RJ11EXT	
Retrofit Gasket (for 4 in. round hole mounting)	PM8G	
CM2000 Retrofit Mounting Adapter	PM8MA	

① The Power Meter units for these models are identical and support the same features (see “Features” on page 9).

Box Contents

Table 1–7: Box contents based on model

Model Description	Box Contents
Power Meter with Integrated Display	<ul style="list-style-type: none"> • Power Meter with integrated display • Hardware kit (63230-500-16) containing: <ul style="list-style-type: none"> — Two retainer clips — Template — Install sheet — Lugs — Plug set — Terminator MCT2W • Power Meter installation manual
Power Meter without Display	<ul style="list-style-type: none"> • Power Meter without display • Hardware kit (63230-500-42) containing: <ul style="list-style-type: none"> — Two retainer clips — Template — Install sheet — Lugs — DIN Slide — Plug set — Terminator MCT2W • Power Meter installation manual
Power Meter with Remote Display	<ul style="list-style-type: none"> • Power Meter without display • Remote display (PM8D) • Remote display adapter (PM8RDA) • Hardware kit (63230-500-42) containing: <ul style="list-style-type: none"> — Two retainer clips — Template — Install sheet — Lugs — DIN Slide — Plug set — Terminator MCT2W • Hardware kit (63230-500-96) containing: <ul style="list-style-type: none"> — Communication cable (CAB12) — Mounting screws • Power Meter installation manual

Features

Table 1–8: Series 800 Power Meter Features

	PM810	PM810 with PM810LOG
True rms metering to the 63rd harmonic	✓	✓
Accepts standard CT and PT inputs	✓	✓
600 volt direct connection on voltage inputs	✓	✓
High accuracy — 0.075% current and voltage (typical conditions)	✓	✓
Min/max readings of metered data	✓	✓
Input metering (five channels) with PM8M22, PM8M26, or PM8M2222 installed	✓	✓
Power quality readings — THD	✓	✓
Downloadable firmware	✓	✓
Easy setup through the integrated or remote display (password protected)	✓	✓
Setpoint-controlled alarm and relay functions	✓	✓
Onboard alarm logging	✓	✓
Wide operating temperature range: –25° to +70°C for the power meter unit, –10° to 50°C for the display	✓	✓
Communications:		
Onboard: one Modbus RS485 (2-wire)	✓	✓
PM8RD: one configurable Modbus RS232/RS485 (2- or 4-wire)	✓	✓
Active energy accuracy: IEC 62053-22 and ANSI C12.20 Class 0.5S	✓	✓
Time clock:		
Volatile	✓	—
Nonvolatile	—	✓
Onboard data logging	0 KB	80 KB
Real-time harmonic magnitudes and angles (I and V) to the 31st harmonic	—	✓

Firmware

This instruction bulletin is written to be used with firmware version 10.5x. See “Identifying the Firmware Version, Model, and Serial Number” on page 100 for instructions on how to determine the firmware version. To download the latest firmware version, follow the steps below:

1. Using a web browser, go to <http://www.powerlogic.com>.
2. Select **United States**.
3. Click **downloads**.
4. Enter your login information, then click **Login**.
5. Click **PM8 Firmware** under the POWERLOGIC section.
6. Follow the instructions on the web page that explains how to download and install the new firmware.

CHAPTER 2—SAFETY PRECAUTIONS

DANGER

HAZARD OF ELECTRIC SHOCK, EXPLOSION OR ARC FLASH

- Apply appropriate personal protective equipment (PPE) and follow safe electrical practices. For example, in the United States, see NFPA 70E.
- This equipment must only be installed and serviced by qualified electrical personnel.
- NEVER work alone.
- Before performing visual inspections, tests, or maintenance on this equipment, disconnect all sources of electric power. Assume that all circuits are live until they have been completely de-energized, tested, and tagged. Pay particular attention to the design of the power system. Consider all sources of power, including the possibility of backfeeding.
- Turn off all power supplying this equipment before working on or inside equipment.
- Always use a properly rated voltage sensing device to confirm that all power is off.
- Beware of potential hazards and carefully inspect the work area for tools and objects that may have been left inside the equipment.
- Use caution while removing or installing panels so that they do not extend into the energized bus; avoid handling the panels, which could cause personal injury.
- The successful operation of this equipment depends upon proper handling, installation, and operation. Neglecting fundamental installation requirements may lead to personal injury as well as damage to electrical equipment or other property.
- Before performing Dielectric (Hi-Pot) or Megger testing on any equipment in which the power meter is installed, disconnect all input and output wires to the power meter. High voltage testing may damage electronic components contained in the power meter.

Failure to follow this instruction will result in death or serious injury.

CHAPTER 3—OPERATION

This section explains how to use a display with a power meter. For a list of all power meter models using an integrated display or a remote display, see Table 1–6 on page 7.

Operating the Display



The power meter is equipped with a large, back-lit LCD display. It can display up to five lines of information plus a sixth row of menu options. Figure 3–1 shows the different parts of the power meter.

Figure 3–1: Power Meter Display

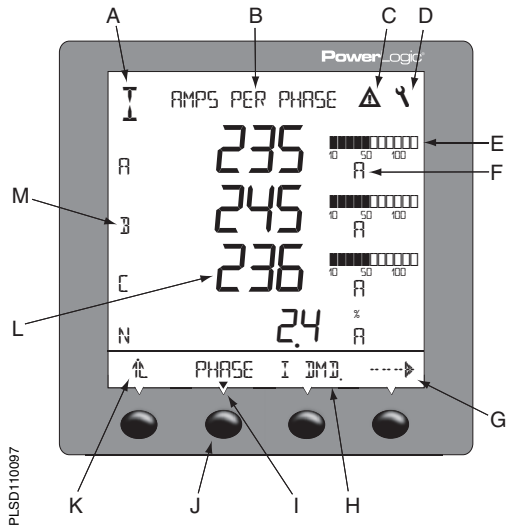
- A. Type of measurement
- B. Screen Title
- C. Alarm indicator
- D. Maintenance icon
- E. Bar Chart (%)
- F. Units
- G. Display more menu items
- H. Menu item
- I. Selected menu indicator
- J. Button
- K. Return to previous menu
- L. Values
- M. Phase



How the Buttons Work

The buttons are used to select menu items, display more menu items in a menu list, and return to previous menus. A menu item appears over one of the four buttons. Pressing a button selects the menu item and displays the menu item's screen. When you have reached the highest menu level, a black triangle appears beneath the selected menu item. To return to the previous menu level, press the button below . To cycle through the menu items in a menu list, press the button below  (see Figure 3-1).

NOTE: Each time you read "press" in this manual, press and release the appropriate button beneath the menu item. For example, if you are asked to "Press PHASE," you would press the button below the PHASE menu item.

Changing Values

When a value is selected, it flashes to indicate that it can be modified. A value is changed by doing the following:

- Press + or – to change numbers or scroll through available options.
- If you are entering more than one number, press  to move to the next number in the sequence.
- To save your changes and move to the next field, press OK.

Menu Overview

The figures below show the menu items of the first two levels of the power meter. Level 1 contains all of the menu items available on the first screen of the power meter. Selecting a Level 1 menu item takes you to the next screen level containing the Level 2 menu items.

NOTE: The  is used to scroll through all menu items on a level.

Figure 3–2: Abbreviated List of PM810(RD) Menu Items



- ① Available on the PM810 only when an optional Power Meter Logging Module (PM810LOG) is installed.
- ② Available with some models.
- ③ IEC is the default for Merlin Gerin branded power meters, and IEEE is the default mode for Square D branded power meters.
- ④ The PM810 has a volatile clock, while the PM810 with a PM810LOG has a nonvolatile clock.

Set Up the Power Meter

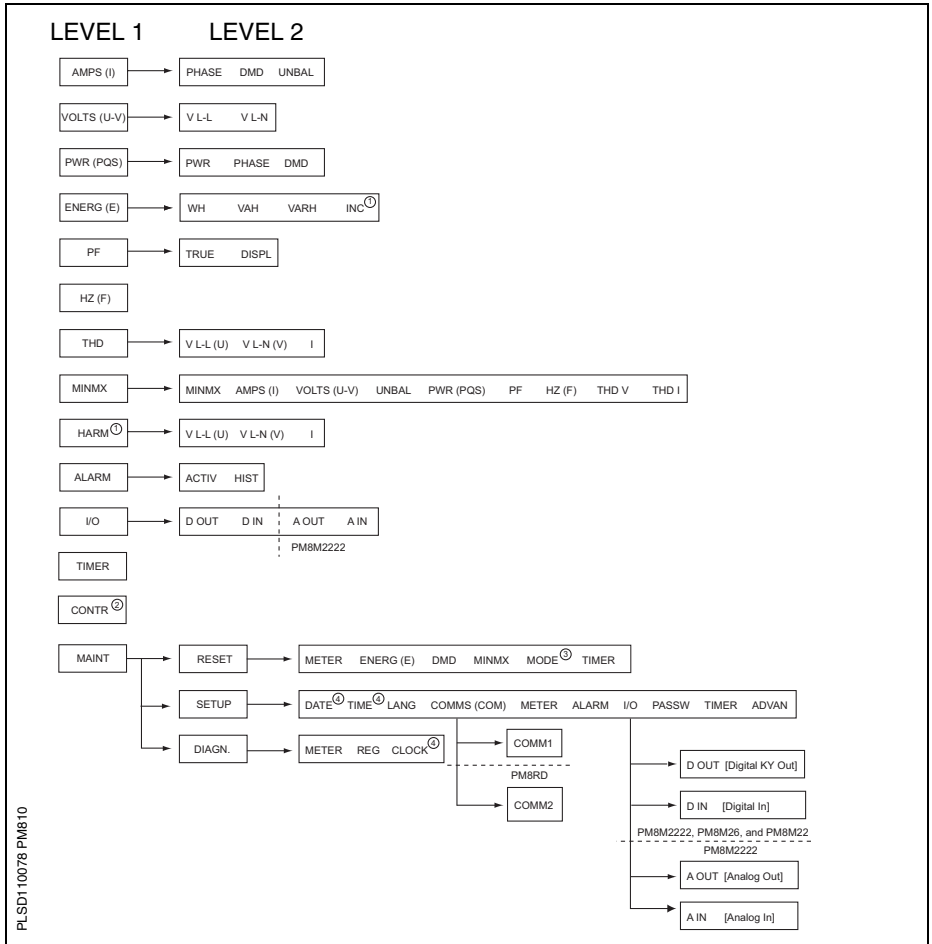
This section explains how to setup a Power Meter using a display. To configure a Power Meter without a display use System Manager Software (SMS).

NOTE: If you are setting up the Power Meter using SMS, it is recommended you set up communications first. The default settings are 1) Protocol: Modbus RTU, 2) Address: 1, 3) Baud rate: 9600, and 4) Parity: Even.

To begin power meter setup, do the following:

1. Scroll through the Level 1 menu list until you see MAINT.
2. Press MAINT.
3. Press SETUP.
4. Enter your password.

NOTE: The default password is 0000.



5. To save the changes, press \uparrow until the SAVE CHANGES? prompt appears, then press YES.

Follow the directions in the following sections to set up the meter.

Power Meter With Integrated Display Communications Setup

Table 3–1: Communications Default Settings

Communications Setting	Default
Protocol	MB.RTU (Modbus RTU)
Address	1
Baud Rate	9600
Parity	Even

1. Press  until COMMS (communications) is visible.
2. Press COMMS (communications).
3. Select the protocol: MB.RTU (Modbus RTU), Jbus, MB. A.8 (Modbus ASCII 8 bits), MB. A.7 (Modbus ASCII 7 bits).
4. Press OK.
5. Enter the ADDR (power meter address).
6. Press OK.
7. Select the BAUD (baud rate).
8. Press OK.
9. Select the parity: EVEN, ODD, or NONE.
10. Press OK.
11. Press  until you are asked to save your changes.
12. Press YES to save the changes.

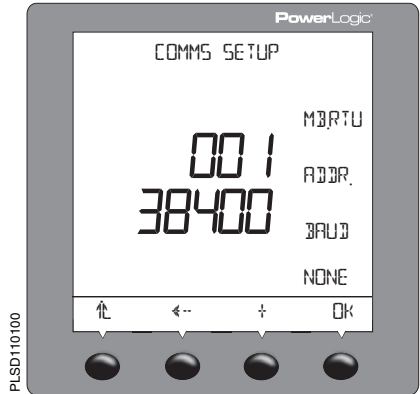

Power Meter With Remote Display Communications Setup

Comm1 Setup

1. Press \rightarrow until COMMS (communications) is visible.
2. Press COMM1 (communications).
3. Select the protocol: MB.RTU (Modbus RTU), Jbus, MB. A.8 (Modbus ASCII 8 bits), MB. A.7 (Modbus ASCII 7 bits).
4. Press OK.
5. Enter the ADDR (power meter address).
6. Press OK.
7. Select the BAUD (baud rate).
8. Press OK.
9. Select the parity: EVEN, ODD, or NONE.
10. Press OK.
11. Press \uparrow until you are asked to save your changes.
12. Press YES to save the changes.

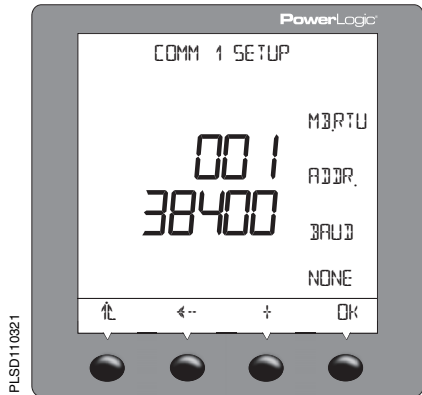

Comm2 Setup

1. Press \rightarrow until COMMS (communications) is visible.
2. Press COMM2 (communications).
3. Select the protocol: MB.RTU (Modbus RTU), Jbus, MB. A.8 (Modbus ASCII 8 bits), MB. A.7 (Modbus ASCII 7 bits).
4. Press OK.
5. Enter the ADDR (power meter address).
6. Press OK.
7. Select the BAUD (baud rate).
8. Press OK.
9. Select the parity: EVEN, ODD, or NONE.
10. Press OK.
11. Press \uparrow until you are asked to save your changes.
12. Press YES to save the changes.

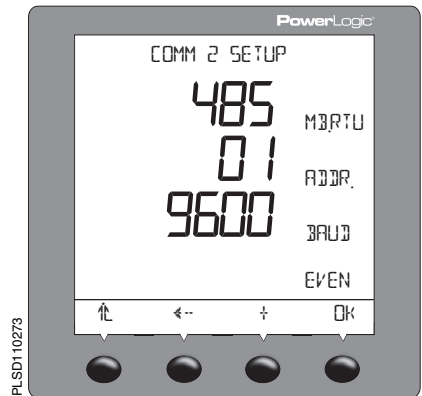

Set Up the Date

1. Press \rightarrow until DATE is visible.
2. Press DATE.
3. Enter the MONTH number.
4. Press OK.
5. Enter the DAY number.
6. Press OK.
7. Enter the YEAR number.
8. Press OK.
9. Select how the date is displayed: M/D/Y, Y/M/D, or D/M/Y).
10. Press \uparrow to return to the SETUP MODE screen.
11. To verify the new settings, press MAINT > DIAGN > CLOCK.

NOTE: The clock in the PM810 is volatile. Each time the meter resets, the PM810 returns to the default clock date/time of 12:00 AM 01-01-1980. See "Date and Time Settings" on page 100 for more information.

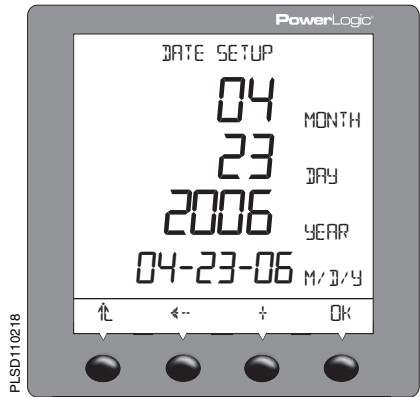

Set Up the Time

1. Press \rightarrow until TIME is visible.
2. Press TIME.
3. Enter the HOUR.
4. Press OK.
5. Enter the MIN (minutes).
6. Press OK.
7. Enter the SEC (seconds).
8. Press OK.
9. Select how the time is displayed: 24H or AM/PM.
10. Press \uparrow to return to the SETUP MODE screen.
11. To verify the new settings, press MAINT > DIAGN > CLOCK.

NOTE: The clock in the PM810 is volatile. Each time the meter resets, the PM810 returns to the default clock date/time of 12:00 AM 01-01-1980. See "Date and Time Settings" on page 100 for more information.

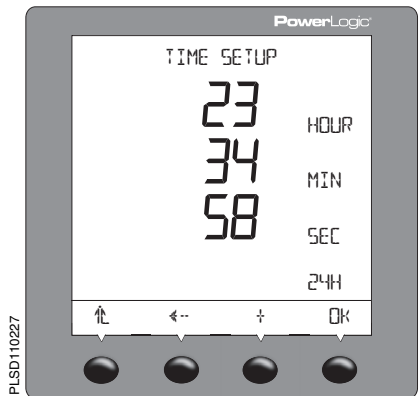

Set Up the Language

1. Press $\leftarrow \rightarrow$ until LANG is visible.
2. Press LANG.
3. Select the language: ENGL (English), SPAN (Spanish), FREN (French), GERMN (German), or RUSSN (Russian).
4. Press OK.
5. Press \uparrow until you are asked to save your changes.
6. Press YES to save the changes.



Set Up CTs

1. Press $\leftarrow \rightarrow$ until METER is visible.
2. Press METER.
3. Press CT.
4. Enter the PRIM (primary CT) number.
5. Press OK.
6. Enter the SEC. (secondary CT) number.
7. Press OK.
8. Press \uparrow until you are asked to save your changes.
9. Press YES to save the changes.

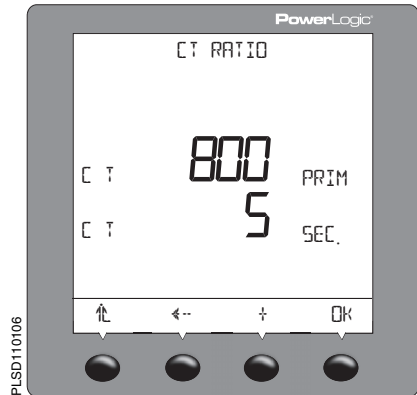

Set Up PTs

1. Press \rightarrow until METER is visible.
2. Press METER.
3. Press PT.
4. Enter the SCALE value: x1, x10, x100, NO PT (for direct connect).
5. Press OK.
6. Enter the PRIM (primary) value.
7. Press OK.
8. Enter the SEC. (secondary) value.
9. Press OK.
10. Press \uparrow until you are asked to save your changes.
11. Press YES to save the changes.

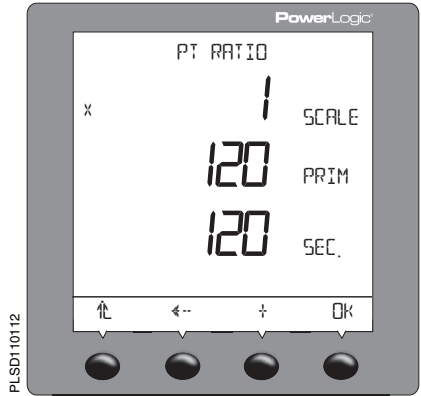

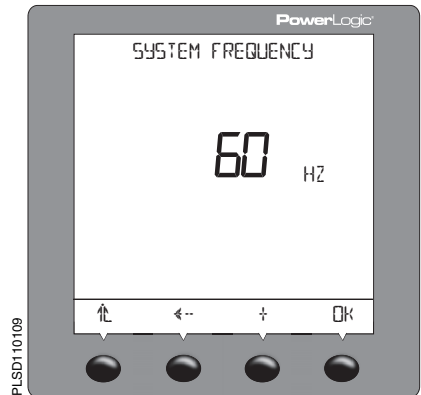

Set Up Frequency

1. Press \rightarrow until METER is visible.
2. Press METER.
3. Press \rightarrow until HZ is visible.
4. Press HZ.
5. Select the frequency.
6. Press OK.
7. Press \uparrow until you are asked to save your changes.
8. Press YES to save the changes.



Set Up the Meter System Type

1. Press  until METER is visible.
2. Press METER.
3. Press  until SYS is visible.
4. Press SYS.
5. Select your system type based on the **(A)** number of wires, **(B)** number of CTs, **(C)** the number of voltage connections (either direct connect or with PT), and **(D)** the SMS system type.
6. Press OK.
7. Press  until you are asked to save your changes.
8. Press YES to save the changes.

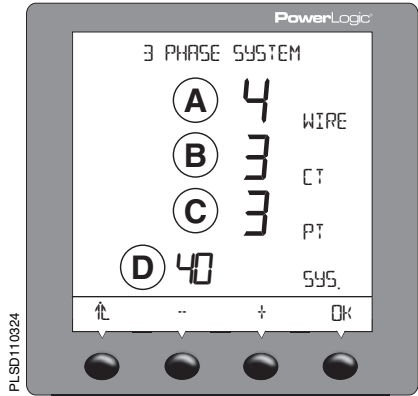

Set Up Alarms

1. Press \rightarrow until ALARM is visible.
2. Press ALARM.
3. Press \leftarrow or \rightarrow to select the alarm you want to edit.
4. Press EDIT.
5. Select to enable or disable the alarm: ENABL (enable) or DISAB (disable).
6. Press OK.
7. Select the PR (priority): NONE, HIGH, MED, or LOW.
8. Press OK.
9. Select how the alarm values are displayed: ABSOL (absolute value) or RELAT (percentage relative to the running average).
10. Enter the PU VALUE (pick-up value).
11. Press OK.
12. Enter the PU DELAY (pick-up delay).
13. Press OK.
14. Enter the DO VALUE (drop-out value).
15. Press OK.
16. Enter the DO DELAY (drop-out delay).
17. Press OK.
18. Press \uparrow to return to the alarm summary screen.
19. Press \uparrow to return to the SETUP screen.

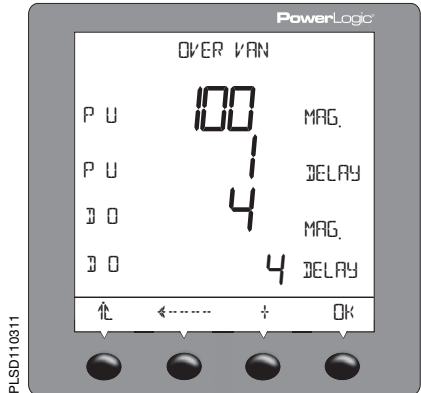
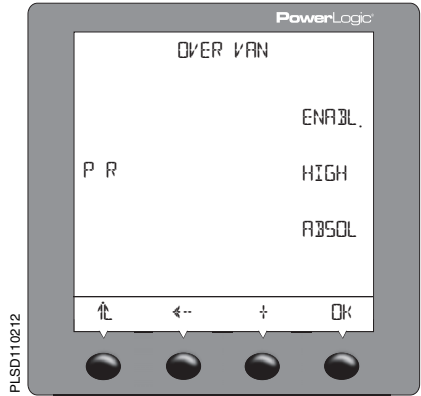

Set Up I/Os

1. Press $\leftarrow \rightarrow$ until I/O is visible.
2. Press I/O.
3. Press D OUT for digital output or D IN for digital input, or press A OUT for analog output or A IN for analog input. Use the $\leftarrow \rightarrow$ button to scroll through these selections.

NOTE: Analog inputs and outputs are available only with the PM8222 option module.

4. Press EDIT.
5. Select the I/O mode based on the I/O type and the user selected mode: NORM., LATCH, TIMED, PULSE, or END OF.
6. Depending on the mode selected, the power meter will prompt you to enter the pulse weight, timer, and control.
7. Press OK.
8. Select EXT. (externally controlled via communications) or ALARM (controlled by an alarm).
9. Press $\uparrow \downarrow$ until you are asked to save your changes.
10. Press YES to save the changes.

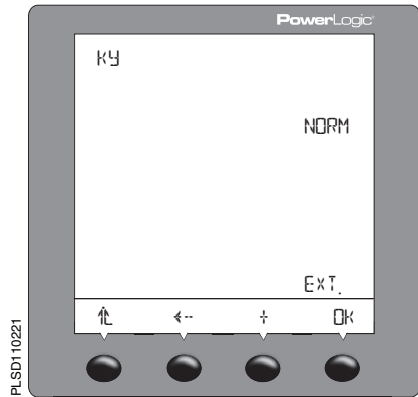

Set Up the Passwords

1. Press $\leftarrow \rightarrow$ until PASSW (password) is visible.
2. Press PASSW.
3. Enter the SETUP password.
4. Press OK.
5. Enter the DIAG (diagnostics) password.
6. Press OK.
7. Enter the ENERG (energy reset) password.
8. Press OK.
9. Enter the MN/MX (minimum/maximum reset) password.
10. Press OK.
11. Press \uparrow until you are asked to save your changes.
12. Press YES to save the changes.

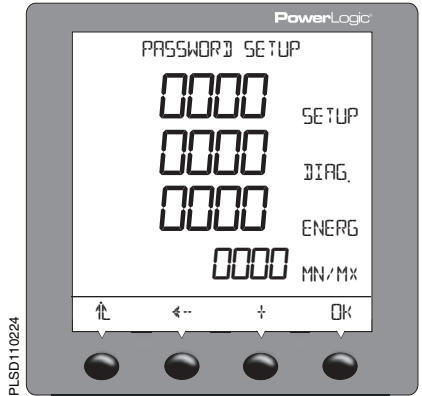

Set Up the Operating Time Threshold

1. Press $\leftarrow \rightarrow$ until TIMER is visible.
2. Press TIMER.
3. Enter the 3-phase current average.
NOTE: The power meter begins counting the operating time whenever the readings are equal to or above the average.
4. Press OK.
5. Press \uparrow until you are asked to save your changes.
6. Press YES to save the changes.

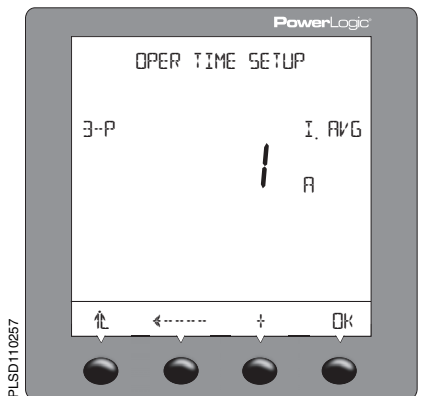

Advanced Power Meter Setup Options

To setup the advanced power meter options, do the following:

1. Scroll through the Level 1 menu list until you see MAINT.
2. Press MAINT.
3. Press SETUP.
4. Enter your password.

NOTE: The default password is 0000.

5. Press $\leftarrow \rightarrow$ until ADVAN (advanced setup) is visible.
6. Press ADVAN.

Follow the directions in the following sections to set up the meter.

Set Up the Phase Rotation

1. Press $\leftarrow \rightarrow$ until ROT (phase rotation) is visible.
2. Press ROT.
3. Select the phase rotation: ABC or CBA.
4. Press OK.
5. Press \uparrow until you are asked to save your changes.
6. Press YES to save the changes.

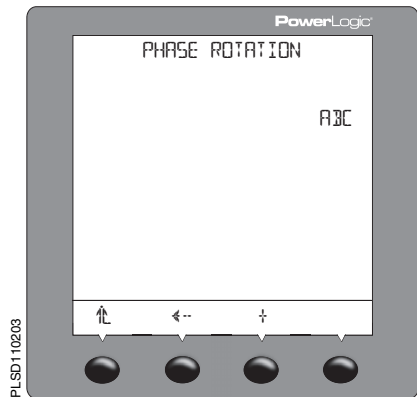

Set Up the Incremental Energy Interval

1. Press $\leftarrow \rightarrow$ until E-INC is visible.
2. Press E-INC (incremental energy).
3. Enter the INTVL (interval). Range is 00 to 1440.
4. Press OK.
5. Press \uparrow until you are asked to save your changes.
6. Press YES to save the changes.

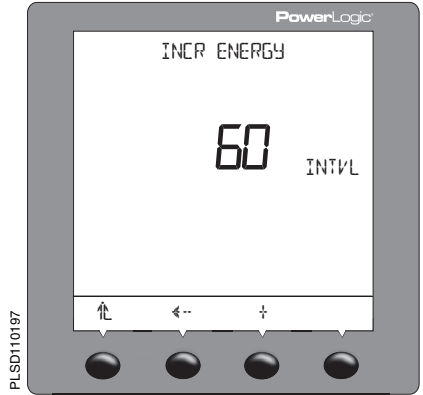

Set Up the THD Calculation

1. Press $\leftarrow \rightarrow$ until THD is visible.
2. Press THD.
3. Select the THD calculation: FUND or RMS.
4. Press OK.
5. Press \uparrow until you are asked to save your changes.
6. Press YES to save the changes.

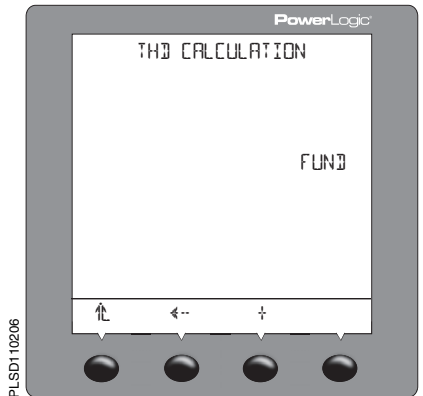

Set Up the VAR/PF Convention

1. Press \rightarrow until PF is visible.
2. Press PF.
3. Select the Var/PF convention: IEEE or IEC.
4. Press OK.
5. Press \uparrow until you are asked to save your changes.
6. Press YES to save the changes.

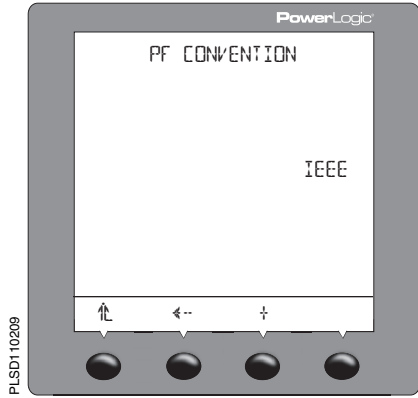

Set Up the Lock Resets

1. Press \rightarrow until LOCK is visible.
2. Press LOCK.
3. Select Y (yes) or N (no) to enable or disable resets for PK.DMD, ENERG, MN/MX, and METER.
4. Press OK.
5. Press \uparrow until you are asked to save your changes.
6. Press YES to save the changes.

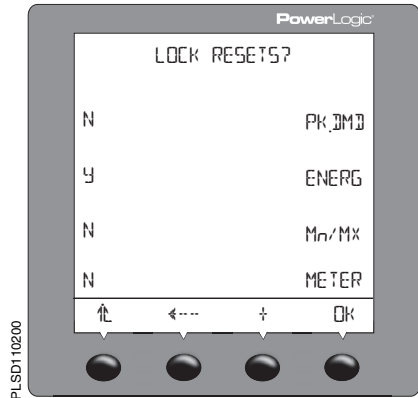

Set Up the Alarm Backlight

1. Press $\leftarrow \rightarrow$ until BLINK is visible.
2. Press BLINK.
3. Enter ON or OFF.
4. Press OK.
5. Press \uparrow until you are asked to save your changes.
6. Press YES to save the changes.



Set Up the Bar Graph

1. Press $\leftarrow \rightarrow$ until BARGR is visible.
2. Press BARGR.
3. Press AMPS or PWR.
4. Select AUTO or MAN. If MAN is selected, press OK and enter the %CT*PT and KW (for PWR) or the %CT and A (for AMPS).
5. Press OK.
6. Press \uparrow until you are asked to save your changes.
7. Press YES to save the changes.

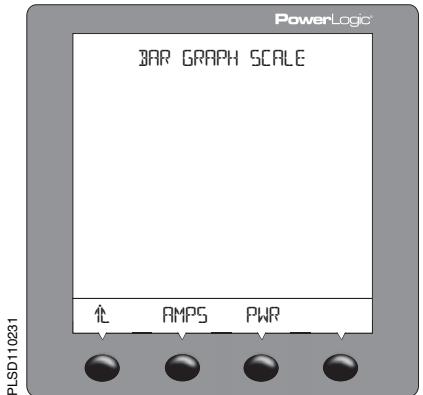

Set Up the Power Demand Configuration

1. Press $\leftarrow \rightarrow$ until DMD is visible.
2. Press DMD.
3. Select the demand configuration. Choices are COMMS, RCOMM, CLOCK, RCLCK, IENGY, THERM, SLIDE, BLOCK, RBLCK, INPUT, and RINPUT.
4. Press OK.
5. Enter the INTVL (interval) and press OK.
6. Enter the SUB-I (sub-interval) and press OK.
7. Press \uparrow until you are asked to save your changes.
8. Press YES to save the changes.

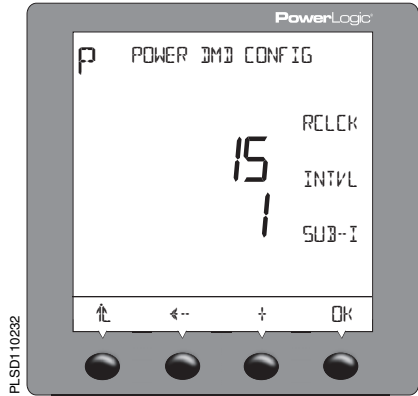

Power Meter Resets

To access the reset options of the power meter, do the following:

1. Scroll through the Level 1 menu list until you see MAINT (maintenance).
2. Press MAINT.
3. Press RESET.
4. Continue by following the instructions in the sections below.

Initialize the Power Meter

Initializing the power meter resets the energy readings, minimum/maximum values, and operating times. Do the following to initialize the power meter:

1. Press \leftarrow until METER is visible.
2. Press METER.
3. Enter the password (the default is 0000).
4. Press YES to initialize the power meter and to return to the RESET MODE screen.

NOTE: We recommend initializing the power meter after you make changes to any of the following: CTs, PTs, frequency, or system type.

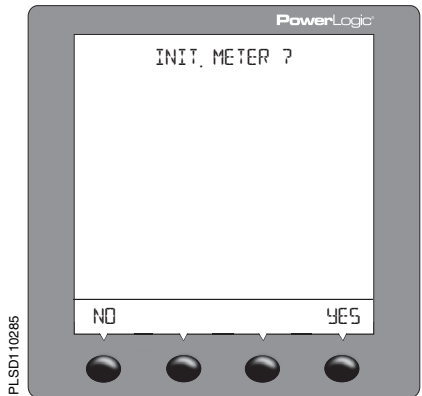

Reset the Accumulated Energy Readings

1. Press $\leftarrow \rightarrow$ until ENER is visible.
2. Press ENERGY.
3. Enter the password (the default is 0000).
4. Press YES to reset the accumulated energy readings and to return to the RESET MODE screen.

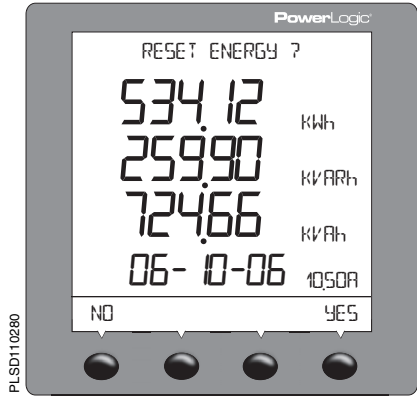

Reset the Accumulated Demand Readings

1. Press $\leftarrow \rightarrow$ until DMD is visible.
2. Press DMD.
3. Enter the password (the default is 0000).
4. Press YES to reset the accumulated demand readings and to return to the RESET MODE screen.

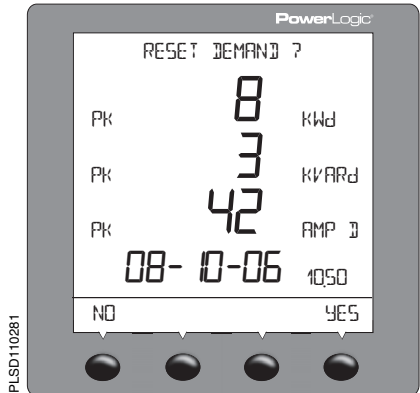

Reset the Minimum/Maximum Values

1. Press $\leftarrow \rightarrow$ until MINMX is visible.
2. Press MINMX.
3. Enter the password (the default is 0000).
4. Press YES to reset the minimum/maximum values and to return to the RESET MODE screen.

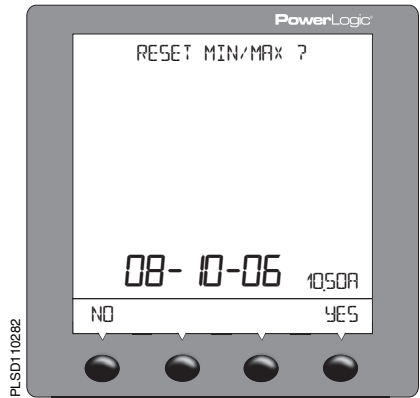

Change the Mode

1. Press $\leftarrow \rightarrow$ until MODE is visible.
2. Press MODE.
3. Press IEEE (default for Square D branded power meters) or IEC (default for Merlin Gerin branded power meters) depending on the operating mode you want to use.

NOTE: Resetting the mode changes the menu labels, power factor conventions, and THD calculations to match the standard mode selected. To customize the mode changes, see the register list.

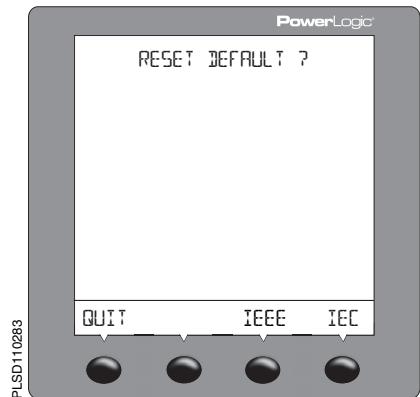

Reset the Accumulated Operating Time

1. Press $\leftarrow \rightarrow$ until TIMER is visible.
2. Press TIMER.
3. Enter the password (the default is 0000).
4. Press YES to reset the accumulated operating time and to return to the RESET MODE screen.

NOTE: The accumulated days, hours, and minutes of operation are reset to zero when YES is pressed.

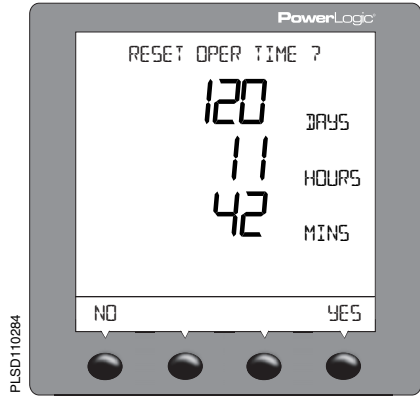

Power Meter Diagnostics

To begin viewing the power meter's model, firmware version, serial number, read and write registers, or check the health status, do the following:

1. Scroll through the Level 1 menu list until you see MAINT (maintenance).
2. Press MAINT.
3. Press DIAG (diagnostics) to open the HEALTH STATUS screen.
4. Continue by following the instructions in the sections below.

View the Meter Information

1. On the HEALTH STATUS screen, press METER (meter information).
2. View the meter information.
3. Press --> to view more meter information.
4. Press ⬆ to return to the HEALTH STATUS screen.

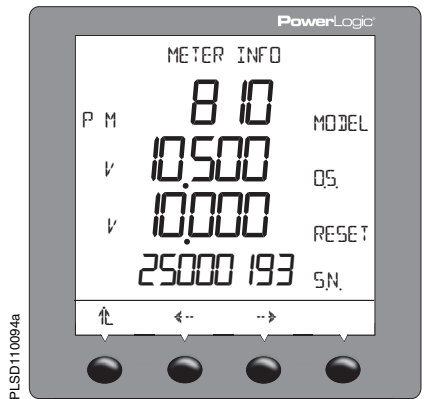

Check the Health Status

1. Press MAINT. (maintenance).
2. Press DIAG. The health status is displayed on the screen.
3. Press \uparrow to return to the MAINTENANCE screen.

NOTE: The wrench icon and the health status code displays when a health problem is detected. For code 1, set up the Date/Time (see “Set Up the Date” and “Set Up the Time” on page 19). For other codes, contact technical support.

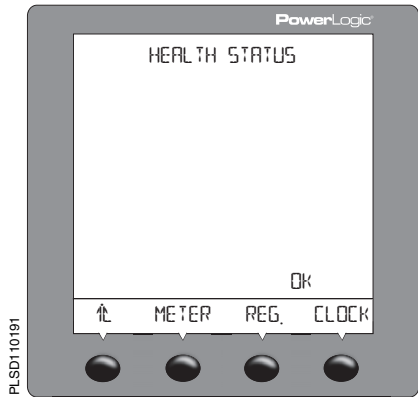

Read and Write Registers

1. On the HEALTH STATUS screen, Press REG (register).
2. Enter the password (the default is 0000).
3. Enter the REG. (register) number.
The HEX (hexadecimal) and DEC (decimal) values of the register number you entered displays.
4. Press OK.
5. Enter the DEC number if necessary.
6. Press \uparrow to return to the DIAGNOSTICS screen.

*NOTE: For more information about using registers, see **Appendix A—Power Meter Register List** on page 105.*

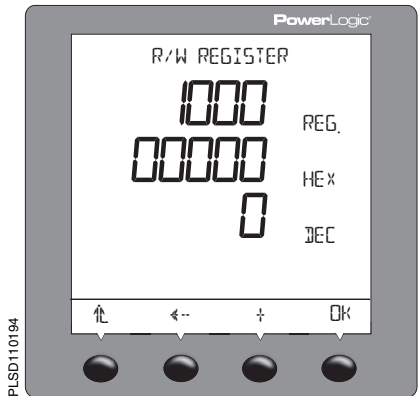

View the Meter Date and Time

1. On the HEALTH STATUS screen, press **CLOCK** (current date and time).
2. View the date and time.
3. Press **↑** to return to the HEALTH STATUS screen.

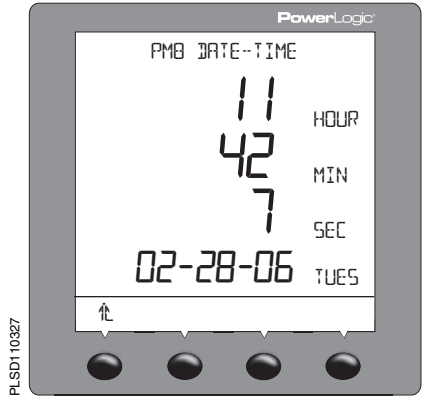

CHAPTER 4—CHAPTER 4—METERING CAPABILITIES

Real-Time Readings

The power meter measures currents and voltages and reports in real time the rms values for all three phases and neutral. In addition, the power meter calculates power factor, real power, reactive power, and more.

Table 4–1 lists some of the real-time readings that are updated every second along with their reportable ranges.

Table 4–1: One-second, Real-time Readings

Real-time Readings	Reportable Range
Current	
Per-Phase	0 to 32,767 A
Neutral	0 to 32,767 A
3-Phase Average	0 to 32,767 A
% Unbalance	0 to 100.0%
Voltage	
Line-to-Line, Per-Phase	0 to 1,200 kV
Line-to-Line, 3-Phase Average	0 to 1,200 kV
Line-to-Neutral, Per-Phase	0 to 1,200 kV
Line-to-Neutral, 3-Phase Average	0 to 1,200 kV
% Unbalance	0 to 100.0%
Real Power	
Per-Phase	0 to ± 3,276.70 MW
3-Phase Total	0 to ± 3,276.70 MW
Reactive Power	
Per-Phase	0 to ± 3,276.70 MVAR
3-Phase Total	0 to ± 3,276.70 MVAR
Apparent Power	
Per-Phase	0 to ± 3,276.70 MVA
3-Phase Total	0 to ± 3,276.70 MVA
Power Factor (True)	
Per-Phase	–0.002 to 1.000 to +0.002
3-Phase Total	–0.002 to 1.000 to +0.002
Power Factor (Displacement)	
Per-Phase	–0.002 to 1.000 to +0.002
3-Phase Total	–0.002 to 1.000 to +0.002
Frequency	
45–65 Hz	23.00 to 67.00 Hz
350–450 Hz	350.00 to 450.00 Hz

Min/Max Values for Real-time Readings

When certain one-second real-time readings reach their highest or lowest value, the Power Meter saves the values in its nonvolatile memory. These values are called the minimum and maximum (min/max) values.

The Power Meter stores the min/max values for the current month and previous month. After the end of each month, the Power Meter moves the current month's min/max values into the previous month's register space and resets the current month's min/max values. The current month's min/max values can be reset manually at any time using the Power Meter display or SMS. After the min/max values are reset, the Power Meter records the date and time. The real-time readings evaluated are:

- Min/Max Voltage L-L
- Min/Max Voltage L-N
- Min/Max Current
- Min/Max Voltage L-L, Unbalance
- Min/Max Voltage L-N, Unbalance
- Min/Max Total True Power Factor
- Min/Max Total Displacement Power Factor
- Min/Max Real Power Total
- Min/Max Reactive Power Total
- Min/Max Apparent Power Total
- Min/Max THD/thd Voltage L-L
- Min/Max THD/thd Voltage L-N
- Min/Max THD/thd Current
- Min/Max Frequency
- Min/Max Voltage N-ground (see the note below)
- Min/Max Current, Neutral (see the note below)

NOTE: Min/Max values for V_{ng} and I_n are not available from the display. Use the display to read registers (see "Read and Write Registers" on page 36) or the PM800 Min/Max Reading Table in SMS (refer to SMS Help for more information).

For each min/max value listed above, the following attributes are recorded by the Power Meter:

- Date/Time of minimum value
- Minimum value
- Phase of recorded minimum value
- Date/Time of maximum value
- Maximum value
- Phase of recorded maximum value

NOTE: Phase of recorded min/max only applies to multi-phase quantities.

NOTE: There are a couple of ways to view the min/max values. The Power Meter display can be used to view the min/max values since the meter was last reset. Using SMS, an instantaneous table with the current month's and previous month's min/max values can be viewed.

Power Factor Min/Max Conventions

All running min/max values, except for power factor, are arithmetic minimum and maximum values. For example, the minimum phase A-B voltage is the lowest value in the range 0 to 1200 kV that has occurred since the min/max values were last reset. In contrast, because the power factor's midpoint is unity (equal to one), the power factor min/max values are not true arithmetic minimums and maximums. Instead, the minimum value represents the measurement closest to -0 on a continuous scale for all real-time readings -0 to 1.00 to +0. The maximum value is the measurement closest to +0 on the same scale.

Figure 4-1 below shows the min/max values in a typical environment in which a positive power flow is assumed. In the figure, the minimum power factor is -0.7 (lagging) and the maximum is 0.8 (leading). Note that the minimum power factor need not be lagging, and the maximum power factor need not be leading. For example, if the power factor values ranged from -0.75 to -0.95, then the minimum power factor would be -0.75 (lagging) and the maximum power factor would be -0.95 (lagging). Both would be negative. Likewise, if the power factor ranged from +0.9 to +0.95, the minimum would be +0.95 (leading) and the maximum would be +0.90 (leading). Both would be positive in this case.

Figure 4-1: Power factor min/max example

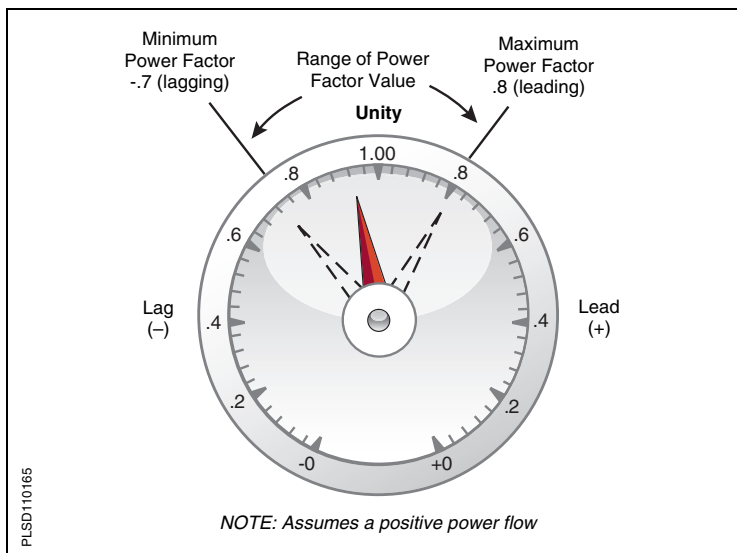

An alternate power factor storage method is also available for use with analog outputs and trending. See the footnotes in “Register List” on page 108 for the applicable registers.

Power Factor Sign Conventions

The power meter can be set to one of two power factor sign conventions: IEEE or IEC. The Series 800 Power Meter defaults to the IEEE power factor sign convention. Figure 4–2 illustrates the two sign conventions. For instructions on changing the power factor sign convention, refer to “Advanced Power Meter Setup Options” on page 26.

Figure 4–2: Power factor sign convention

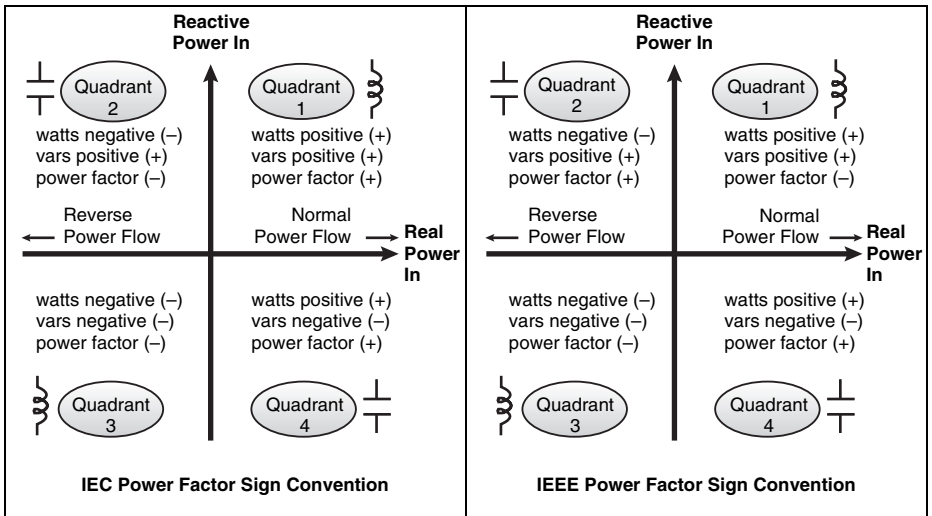
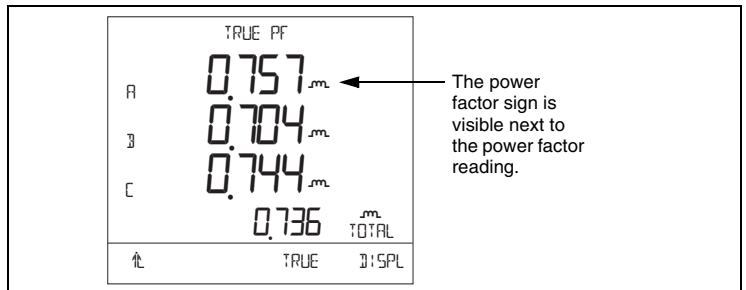

Figure 4–3: Power Factor Display Example



Demand Readings

The power meter provides a variety of demand readings, including coincident readings and predicted demands. Table 4–2 lists the available demand readings and their reportable ranges.

Table 4–2: Demand Readings

Demand Readings	Reportable Range
Demand Current, Per-Phase, 3Ø Average, Neutral	
Last Complete Interval	0 to 32,767 A
Peak	0 to 32,767 A
Average Power Factor (True), 3Ø Total	
Last Complete Interval	–0.002 to 1.000 to +0.002
Coincident with kW Peak	–0.002 to 1.000 to +0.002
Coincident with kVAR Peak	–0.002 to 1.000 to +0.002
Coincident with kVA Peak	–0.002 to 1.000 to +0.002
Demand Real Power, 3Ø Total	
Last Complete Interval	0 to ± 3276.70 MW
Predicted	0 to ± 3276.70 MW
Peak	0 to ± 3276.70 MW
Coincident kVA Demand	0 to ± 3276.70 MVA
Coincident kVAR Demand	0 to ± 3276.70 MVAR
Demand Reactive Power, 3Ø Total	
Last Complete Interval	0 to ± 3276.70 MVAR
Predicted	0 to ± 3276.70 MVAR
Peak	0 to ± 3276.70 MVAR
Coincident kVA Demand	0 to ± 3276.70 MVA
Coincident kW Demand	0 to ± 3276.70 MW
Demand Apparent Power, 3Ø Total	
Last Complete Interval	0 to ± 3276.70 MVA
Predicted	0 to ± 3276.70 MVA
Peak	0 to ± 3276.70 MVA
Coincident kW Demand	0 to ± 3276.70 MW
Coincident kVAR Demand	0 to ± 3276.70 MVAR

Demand Power Calculation Methods

Demand power is the energy accumulated during a specified period divided by the length of that period. How the power meter performs this calculation depends on the method you select. To be compatible with electric utility billing practices, the power meter provides the following types of demand power calculations:

- Block Interval Demand
- Synchronized Demand
- Thermal Demand

The default demand calculation is set to sliding block with a 15 minute interval. You can set up any of the demand power calculation methods from SMS. See the SMS online help to perform the set up using the software.

Block Interval Demand

In the block interval demand method, you select a “block” of time that the power meter uses for the demand calculation. You choose how the power meter handles that block of time (interval). Three different modes are possible:

- **Sliding Block.** In the sliding block interval, you select an interval from 1 to 60 minutes (in 1-minute increments). If the interval is between 1 and 15 minutes, the demand calculation *updates every 15 seconds*. If the interval is between 16 and 60 minutes, the demand calculation *updates every 60 seconds*. The power meter displays the demand value for the last completed interval.
- **Fixed Block.** In the fixed block interval, you select an interval from 1 to 60 minutes (in 1-minute increments). The power meter calculates and updates the demand at the end of each interval.
- **Rolling Block.** In the rolling block interval, you select an interval and a subinterval. The subinterval must divide evenly into the interval. For example, you might set three 5-minute subintervals for a 15-minute interval. Demand is *updated at each subinterval*. The power meter displays the demand value for the last completed interval.

Figure 4–4 below illustrates the three ways to calculate demand power using the block method. For illustration purposes, the interval is set to 15 minutes.

Figure 4-4: Block Interval Demand Examples

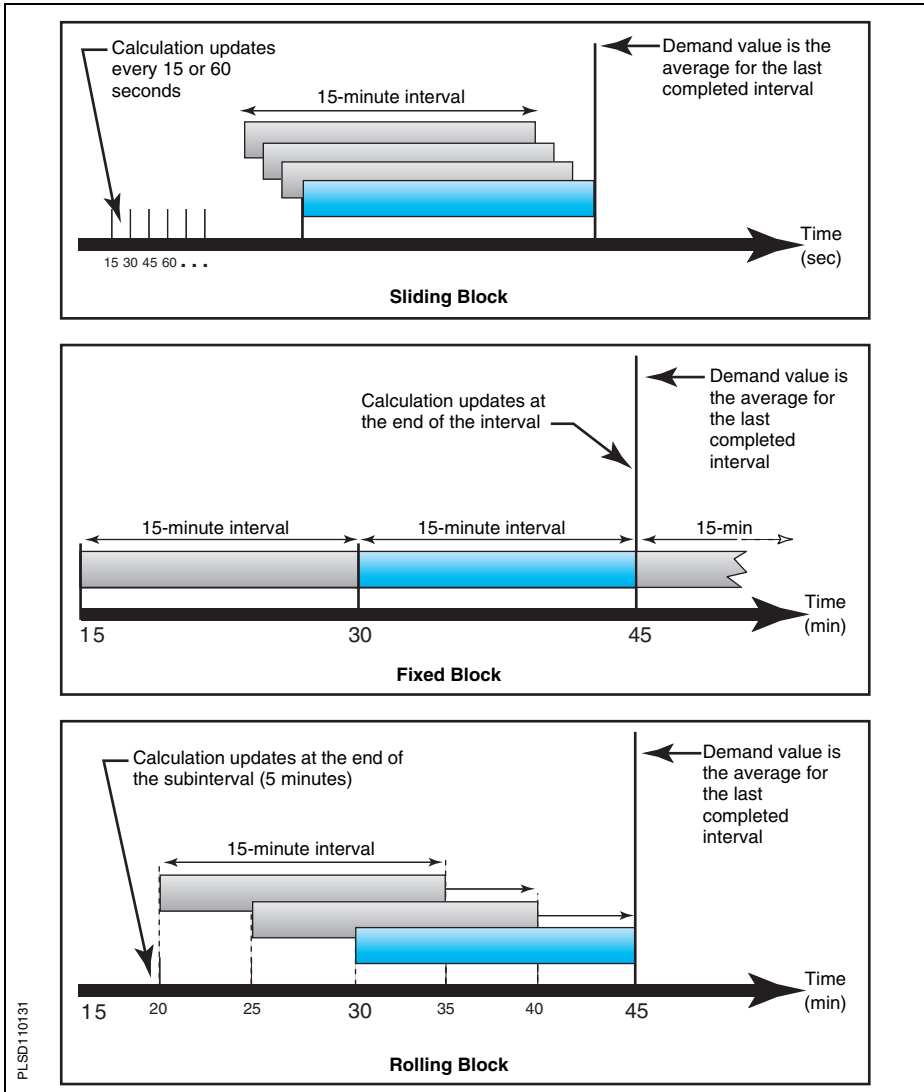

Synchronized Demand

The demand calculations can be synchronized by accepting an external pulse input, a command sent over communications, or by synchronizing to the internal real-time clock.

- **Input Synchronized Demand.** You can set up the power meter to accept an input such as a demand synch pulse from an external source. The power meter then uses the same time interval as the other meter for each demand calculation. You can use the standard digital input installed on the meter to receive the synch pulse. When setting up this type of demand, you select whether it will be input-synchronized block or input-synchronized rolling block demand. The rolling block demand requires that you choose a subinterval.
- **Command Synchronized Demand.** Using command synchronized demand, you can synchronize the demand intervals of multiple meters on a communications network. For example, if a PLC input is monitoring a pulse at the end of a demand interval on a utility revenue meter, you could program the PLC to issue a command to multiple meters whenever the utility meter starts a new demand interval. Each time the command is issued, the demand readings of each meter are calculated for the same interval. When setting up this type of demand, you select whether it will be command-synchronized block or command-synchronized rolling block demand. The rolling block demand requires that you choose a subinterval. See **Appendix B—Using the Command Interface** on page 179 for more information.
- **Clock Synchronized Demand (Requires PM810LOG).** You can synchronize the demand interval to the internal real-time clock in the power meter. This enables you to synchronize the demand to a particular time, typically on the hour. The default time is 12:00 am. If you select another time of day when the demand intervals are to be synchronized, the time must be in minutes from midnight. For example, to synchronize at 8:00 am, select 480 minutes. When setting up this type of demand, you select whether it will be clock-synchronized block or clock-synchronized rolling block demand. The rolling block demand requires that you choose a subinterval.

Thermal Demand

The thermal demand method calculates the demand based on a thermal response, which mimics thermal demand meters. The demand calculation updates at the end of each interval. You select the demand interval from 1 to 60 minutes (in 1-minute increments). In Figure 4–5 the interval is set to 15 minutes for illustration purposes.

Figure 4–5: Thermal Demand Example

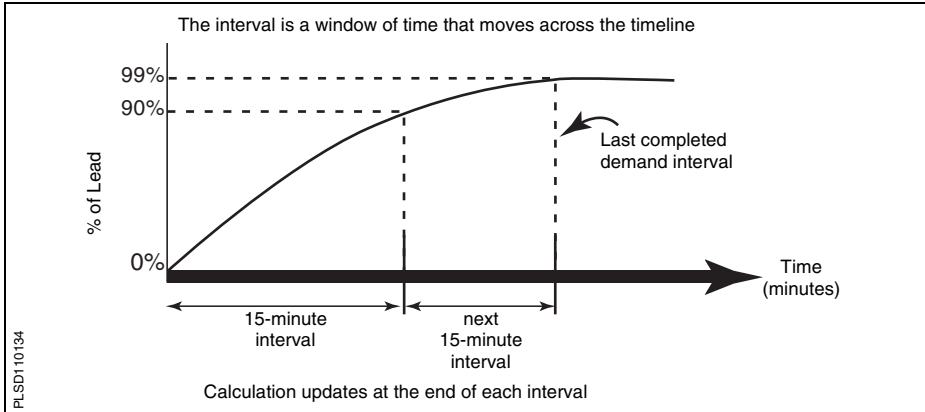

Demand Current

The power meter calculates demand current using the thermal demand method. The default interval is 15 minutes, but you can set the demand current interval between 1 and 60 minutes in 1-minute increments.

Predicted Demand

The power meter calculates predicted demand for the end of the present interval for kW, kVAR, and kVA demand. This prediction takes into account the energy consumption thus far within the present (partial) interval and the present rate of consumption. The prediction is updated every second.

Figure 4–6 illustrates how a change in load can affect predicted demand for the interval.

Figure 4–6: Predicted Demand Example

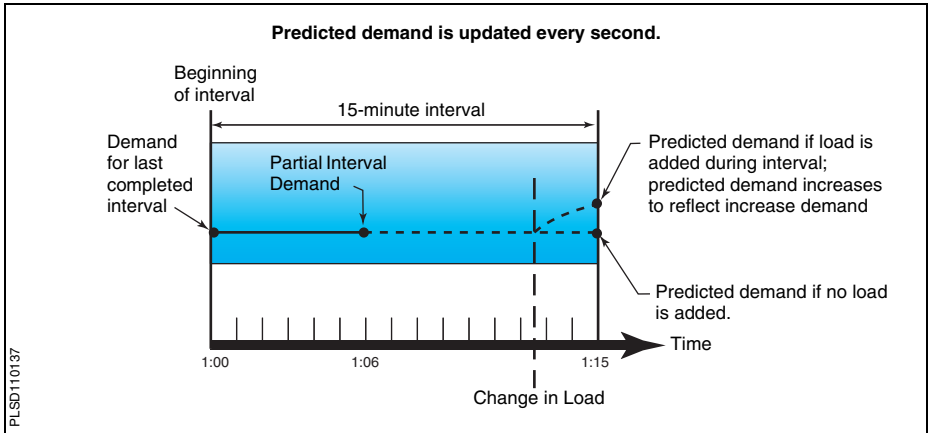

Peak Demand

In nonvolatile memory, the power meter maintains a running maximum for power demand values, called “peak demand.” The peak is the highest average for each of these readings: kWd, kVARD, and kVAD since the last reset. The power meter also stores the date and time when the peak demand occurred. In addition to the peak demand, the power meter also stores the coinciding average 3-phase power factor. The average 3-phase power factor is defined as “demand kW/demand kVA” for the peak demand interval. Table 4–2 on page 44 lists the available peak demand readings from the power meter.

You can reset peak demand values from the power meter display. From the Main Menu, select MAINT > RESET > DMD. You can also reset the values over the communications link by using SMS. See the SMS online help for instructions.

NOTE: You should reset peak demand after changes to basic meter setup, such as CT ratio or system type.

The power meter also stores the peak demand during the last incremental energy interval. See “Energy Readings” on page 53 for more about incremental energy readings.

Generic Demand

The power meter can perform any of the demand calculation methods, described earlier in this chapter, on up to 10 quantities that you choose. For generic demand, you do the following in SMS:

- **Select the demand calculation method** (thermal, block interval, or synchronized).
- **Select the demand interval** (from 5–60 minutes in 1–minute increments) and select the demand subinterval (if applicable).
- **Select the quantities** on which to perform the demand calculation. You must also select the units and scale factor for each quantity.

Use the Device Setup > Basic Setup tab in SMS to create the generic demand profiles. For each quantity in the demand profile, the power meter stores four values:

- Partial interval demand value
- Last completed demand interval value
- Minimum values (date and time for each is also stored)
- Peak demand value (date and time for each is also stored)

You can reset the minimum and peak values of the quantities in a generic demand profile by using one of two methods:

- Use SMS (see the SMS online help file), or
- Use the command interface.

Command 5115 resets the generic demand profile. See **Appendix B—Using the Command Interface** on page 179 for more about the command interface.

Input Metering Demand

The power meter has five input pulse metering channels, but only one digital input. Digital inputs can be added by installing one or more option modules (PM8M22, PM8M26, or PM8M2222). The input pulse metering channels count pulses received from one or more digital inputs assigned to that channel. Each channel requires a consumption pulse weight, consumption scale factor, demand pulse weight, and demand scale factor. The consumption pulse weight is the number of watt-hours or kilowatt-hours per pulse. The consumption scale factor is a factor of 10 multiplier that determines the format of the value. For example, if each incoming pulse represents 125 Wh, and you want consumption data in watt-hours, the consumption pulse weight is 125 and the consumption scale factor is zero. The resulting calculation is 125×10^0 , which equals 125 watt-hours per pulse. If you want the consumption data in kilowatt-hours, the calculation is 125×10^{-3} , which equals 0.125 kilowatt-hours per pulse. Time must be taken into account for demand data so you begin by calculating demand pulse weight using the following formula:

$$\text{watts} = \frac{\text{watt-hours}}{\text{pulse}} \times \frac{3600 \text{ seconds}}{\text{hour}} \times \frac{\text{pulse}}{\text{second}}$$

If each incoming pulse represents 125 Wh, using the formula above you get 450,000 watts. If you want demand data in watts, the demand pulse weight is 450 and the demand scale factor is three. The calculation is 450×10^3 , which equals 450,000 watts. If you want the demand data in kilowatts, the calculation is 450×10^0 , which equals 450 kilowatts.

NOTE: The power meter counts each input transition as a pulse. Therefore, for an input transition of OFF-to-ON and ON-to-OFF will be counted as two pulses. For each channel, the power meter maintains the following information:

- Total consumption
- Last completed interval demand—calculated demand for the last completed interval.
- Partial interval demand—demand calculation up to the present point during the interval.

- Peak demand—highest demand value since the last reset of the input pulse demand. The date and time of the peak demand is also saved.
- Minimum demand—lowest demand value since the last reset of the input pulse demand. The date and time of the minimum demand is also saved.

To use the channels feature, first set up the digital inputs from the display (see “Set Up I/Os” on page 24). Then using SMS, you must set the I/O operating mode to Normal and set up the channels. The demand method and interval that you select applies to all channels. See the SMS online help for instructions on device set up of the power meter.

Energy Readings

The power meter calculates and stores accumulated energy values for real and reactive energy (kWh and kVARh) both into and out of the load, and also accumulates absolute apparent energy. Table 4–3 lists the energy values the power meter can accumulate.

Table 4–3: Energy Readings

Energy Reading, 3-Phase	Reportable Range	Shown on the Display
Accumulated Energy		
Real (Signed/Absolute) ①	-9,999,999,999,999,999 to 9,999,999,999,999,999 Wh	0000.000 kWh to 99,999.99 MWh and 0000.000 to 99,999.99 MVARh
Reactive (Signed/Absolute) ①	-9,999,999,999,999,999 to 9,999,999,999,999,999 VARh	
Real (In)	0 to 9,999,999,999,999,999 Wh	
Real (Out) ①	0 to 9,999,999,999,999,999 Wh	
Reactive (In)	0 to 9,999,999,999,999,999 VARh	
Reactive (Out) ①	0 to 9,999,999,999,999,999 VARh	
Apparent	0 to 9,999,999,999,999,999 VAh	
Accumulated Energy, Conditional		
Real (In) ①	0 to 9,999,999,999,999,999 Wh	Not shown on the display. Readings are obtained only through the communications link.
Real (Out) ①	0 to 9,999,999,999,999,999 Wh	
Reactive (In) ①	0 to 9,999,999,999,999,999 VARh	
Reactive (Out) ①	0 to 9,999,999,999,999,999 VARh	
Apparent ①	0 to 9,999,999,999,999,999 VAh	
Accumulated Energy, Incremental		
Real (In) ①	0 to 999,999,999,999 Wh	Not shown on the display. Readings are obtained only through the communications link.
Real (Out) ①	0 to 999,999,999,999 Wh	
Reactive (In) ①	0 to 999,999,999,999 VARh	
Reactive (Out) ①	0 to 999,999,999,999 VARh	
Apparent ①	0 to 999,999,999,999 VAh	
Reactive Energy		
Quadrant 1 ①	0 to 999,999,999,999 VARh	Not shown on the display. Readings are obtained only through the communications link.
Quadrant 2 ①	0 to 999,999,999,999 VARh	
Quadrant 3 ①	0 to 999,999,999,999 VARh	
Quadrant 4 ①	0 to 999,999,999,999 VARh	
① Not shown on the power meter display.		

The power meter can accumulate the energy values shown in Table 4–3 in one of two modes: signed or unsigned (absolute). In signed mode, the power meter considers the direction of power flow, allowing the magnitude of accumulated energy to increase and decrease. In unsigned mode, the power meter accumulates energy as a positive value, regardless of the direction of power flow. In other words, the energy value increases, even during reverse power flow. The default accumulation mode is unsigned.

You can view accumulated energy from the display. The resolution of the energy value will automatically change through the range of 000.000 kWh to 000,000 MWh (000.000 kVAh to 000,000 MVARh), or it can be fixed. See **Appendix A—Power Meter Register List** on page 105 for the contents of the registers.

For conditional accumulated energy readings, you can set the real, reactive, and apparent energy accumulation to OFF or ON when a particular condition occurs. You can do this over the communications link using a command, or from a digital input change. For example, you may want to track accumulated energy values during a particular process that is controlled by a PLC. The power meter stores the date and time of the last reset of conditional energy in nonvolatile memory.

Also, the power meter provides an additional energy reading that is only available over the communications link:

- **Four-quadrant reactive accumulated energy readings.** The power meter accumulates reactive energy (kVARh) in four quadrants as shown in Figure 4–7. The registers operate in unsigned (absolute) mode in which the power meter accumulates energy as positive.

Figure 4–7: Reactive energy accumulates in four quadrants

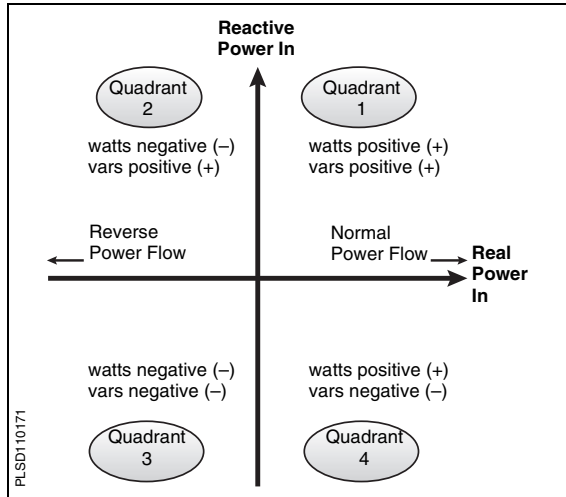

Energy-Per-Shift (PM810 with PM810LOG)

The energy-per-shift feature allows the power meter to group energy usage based on three groups: 1st shift, 2nd shift, and 3rd shift. These groups provide a quick, historical view of energy usage and energy cost during each shift. All data is stored in nonvolatile memory.

Table 4–4: Energy-per-shift recorded values

Category	Recorded Values
Time Scales	<ul style="list-style-type: none"> • Today • Yesterday • This Week • Last Week • This Month • Last Month
Energy	<ul style="list-style-type: none"> • Real • Apparent
Energy Cost	<ul style="list-style-type: none"> • Today • Yesterday • This Week • Last Week • This Month • Last Month
User Configuration	<ul style="list-style-type: none"> • Meter Reading Date • Meter Reading Time of Day • 1st Day of the Week

Configuration

The start time of each shift is configured by setting registers using the display or by using SMS. The table below summarizes the quantities needed to configure energy-per-shift using register numbers. For SMS setup, refer to SMS Help.

Table 4–5: Energy-per-shift recorded values

Quantity	Register Number(s)	Description
Shift Start Time	<ul style="list-style-type: none"> • 1st shift: 16171 • 2nd shift: 16172 • 3rd shift: 16173 	For each shift, enter the minutes from midnight at which the shift starts. Defaults: 1st shift = 420 minutes (7:00 am) 2nd shift = 900 minutes (3:00 pm) 3rd shift = 1380 minutes (11:00 pm)
Cost per kWhr	<ul style="list-style-type: none"> • 1st shift: 16174 • 2nd shift: 16175 • 3rd shift: 16176 	Enter the cost per kWhr for each shift.
Monetary Scale Factor	16177	The scale factor multiplied by the monetary units to determine the energy cost. Values: -3 to 3 Default: 0

Power Analysis Values

The power meter provides a number of power analysis values that can be used to detect power quality problems, diagnose wiring problems, and more. Table 4–6 on page 59 summarizes the power analysis values.

- **THD.** Total Harmonic Distortion (THD) is a quick measure of the total distortion present in a waveform and is the ratio of harmonic content to the fundamental. It provides a general indication of the “quality” of a waveform. THD is calculated for both voltage and current. The power meter uses the following equation to calculate THD where H is the harmonic distortion:

$$\text{THD} = \frac{\sqrt{H_2^2 + H_3^2 + H_4^2 + \dots}}{H_1} \times 100\%$$

- **thd.** An alternate method for calculating Total Harmonic Distortion, used widely in Europe. It considers the total harmonic current and the total rms content rather than fundamental content in the calculation. The power meter calculates thd for both voltage and current. The power meter uses the following equation to calculate thd where H is the harmonic distortion:

$$\text{thd} = \frac{\sqrt{H_2^2 + H_3^2 + H_4^2 + \dots}}{\text{Total rms}} \times 100\%$$

- **Displacement Power Factor.** Power factor (PF) represents the degree to which voltage and current coming into a load are out of phase. Displacement power factor is based on the angle between the fundamental components of current and voltage.

Harmonic Values. Harmonics can reduce the capacity of the power system. The power meter determines the individual per-phase harmonic magnitudes and angles through the 31st harmonic for all currents and voltages. The harmonic magnitudes can be formatted as either a percentage of the fundamental (default), a percentage of the rms value, or the actual rms value. Refer to “Setting Up Individual Harmonic Calculations” on page 192 for information on how to configure harmonic calculations.

Table 4–6: Power Analysis Values

Value	Reportable Range
THD—Voltage, Current	
3-phase, per-phase, neutral	0 to 3,276.7%
thd—Voltage, Current	
3-phase, per-phase, neutral	0 to 3,276.7%
Fundamental Voltages (per phase)	
Magnitude	0 to 1,200 kV
Angle	0.0 to 359.9°
Fundamental Currents (per phase)	
Magnitude	0 to 32,767 A
Angle	0.0 to 359.9°
Miscellaneous	
Displacement P.F. (per phase, 3-phase)	–0.002 to 1.000 to +0.002
Phase Rotation	ABC or CBA
Unbalance (current and voltage) ①	0.0 to 100.0%
Individual Current and Voltage Harmonic Magnitudes ②	0 to 327.67%
Individual Current and Voltage Harmonic Angles ②	0.0° to 359.9°
① Readings are obtained only through communications.	
② PM810 with a PM810LOG: Current and Voltage Harmonic Magnitude and Angles 2, 3, 4, 5, 6, 7, 8, 9, 10, 11, 12, and 13 are shown on the display.	

CHAPTER 5—INPUT/OUTPUT CAPABILITIES

Digital Inputs

The power meter includes one solid-state digital input. A digital input is used to detect digital signals. For example, the digital input can be used to determine circuit breaker status, count pulses, or count motor starts. The digital input can also be associated with an external relay. You can log digital input transitions as events in the power meter's on-board alarm log. The event is date and time stamped with resolution to the second. The power meter counts OFF-to-ON transitions for each input. You can view the count for each input using the Digital Inputs screen, and you can reset this value using the command interface. Figure 5–1 is an example of the Digital Inputs screen.

Figure 5–1: Digital Inputs Screen

- A. Lit bargraph indicates that the input is ON. For analog inputs or outputs, the bargraph indicates the output percentage.
- B. S1 is common to all meters and represents standard digital input.
- C. A-S1 and A-S2 represent I/O point numbers on the first (A) module.
- D. Use the arrow buttons to scroll through the remaining I/O points. Point numbers beginning with "B" are on the second module. See Table B–3 on page 185 for a complete list of I/O point numbers.

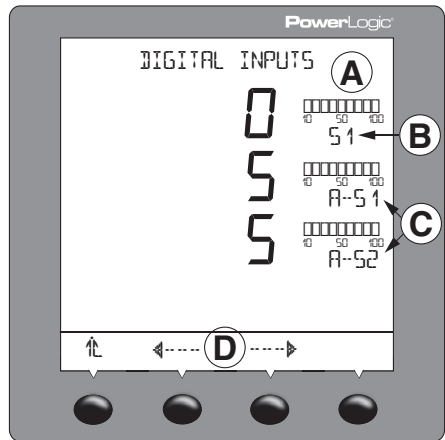

The digital input has three operating modes:

- **Normal**—Use the normal mode for simple on/off digital inputs. In normal mode, digital inputs can be used to count KY pulses for demand and energy calculation.
- **Demand Interval Synch Pulse**—you can configure any digital input to accept a demand synch pulse from a utility demand meter (see “Demand Synch Pulse Input” on page 63 of this chapter for more about this topic). For each demand profile, you can designate only one input as a demand synch input.
- **Conditional Energy Control**—you can configure one digital input to control conditional energy (see “Energy Readings” on page 53 in **Chapter 4—Metering Capabilities** for more about conditional energy).

NOTE: By default, the digital input is named DIG IN S02 and is set up for normal mode.

For custom setup, use SMS to define the name and operating mode of the digital input. The name is a 16-character label that identifies the digital input. The operating mode is one of those listed above. See the SMS online help for instructions on device set up of the power meter.

Demand Synch Pulse Input

You can configure the power meter to accept a demand synch pulse from an external source such as another demand meter. By accepting demand synch pulses through a digital input, the power meter can make its demand interval “window” match the other meter’s demand interval “window.” The power meter does this by “watching” the digital input for a pulse from the other demand meter. When it sees a pulse, it starts a new demand interval and calculates the demand for the preceding interval. The power meter then uses the same time interval as the other meter for each demand calculation. Figure 5–2 illustrates this point. See “Synchronized Demand” on page 47 in **Chapter 4—Metering Capabilities** for more about demand calculations.

When in demand synch pulse operating mode, the power meter will not start or stop a demand interval without a pulse. The maximum allowable time between pulses is 60 minutes. If 66 minutes (110% of the demand interval) pass before a synch pulse is received, the power meter throws out the demand calculations and begins a new calculation when the next pulse is received. Once in synch with the billing meter, the power meter can be used to verify peak demand charges.

Important facts about the power meter’s demand synch feature are listed below:

- Any installed digital input can be set to accept a demand synch pulse.
- Each system can choose whether to use an external synch pulse, but only one demand synch pulse can be brought into the meter for each demand system. One input can be used to synchronize any combination of the demand systems.
- The demand synch feature can be set up from SMS. See the SMS online help for instructions on device set up of the power meter.

Figure 5–2: Demand synch pulse timing

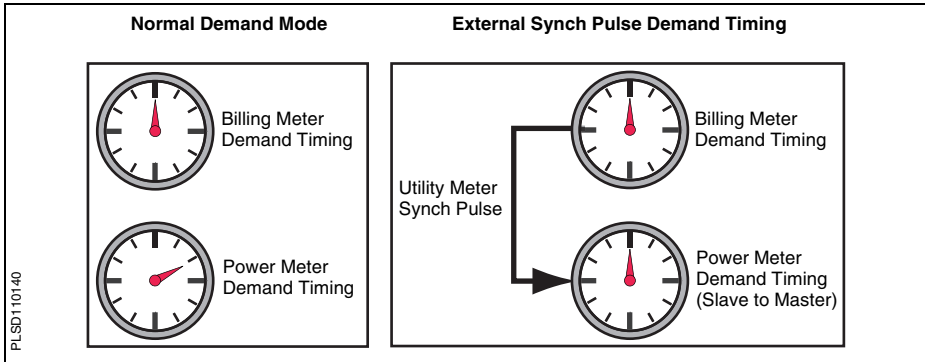

Relay Output Operating Modes

The relay output defaults to external control, but you can choose whether the relay is set to external or internal control:

- **Remote (external) control**—the relay is controlled either from a PC using SMS or a programmable logic controller using commands via communications.
- **Power meter (internal) control**—the relay is controlled by the power meter in response to a set-point controlled alarm condition, or as a pulse initiator output. Once you've set up a relay for power meter control, you can no longer operate the relay remotely. However, you can temporarily override the relay, using SMS.

NOTE: If any basic setup parameters or I/O setup parameters are modified, all relay outputs will be de-energized.

The 11 relay operating modes are as follows:

- **Normal**
 - *Remotely Controlled:* Energize the relay by issuing a command from a remote PC or programmable controller. The relay remains energized until a command to de-energize is issued from the remote PC or programmable controller, or until the power meter loses control power. When control power is restored, the relay is not automatically re-energized.
 - *Power Meter Controlled:* When an alarm condition assigned to the relay occurs, the relay is energized. The relay is not de-energized until *all* alarm conditions assigned to the relay have dropped out, the power meter loses control power, or the

alarms are over-ridden using SMS software. If the alarm condition is still true when the power meter regains control power, the relay will be re-energized.

- **Latched**

- *Remotely Controlled:* Energize the relay by issuing a command from a remote PC or programmable controller. The relay remains energized until a command to de-energize is issued from a remote PC or programmable controller, or until the power meter loses control power. When control power is restored, the relay will not be re-energized.
- *Power Meter Controlled:* When an alarm condition assigned to the relay occurs, the relay is energized. The relay remains energized—even after all alarm conditions assigned to the relay have dropped out—until a command to de-energize is issued from a remote PC or programmable controller, until the high priority alarm log is cleared from the display, or until the power meter loses control power. When control power is restored, the relay will not be re-energized if the alarm condition is not TRUE.

- **Timed**

- *Remotely Controlled:* Energize the relay by issuing a command from a remote PC or programmable controller. The relay remains energized until the timer expires, or until the power meter loses control power. If a new command to energize the relay is issued before the timer expires, the timer restarts. If the power meter loses control power, the relay will not be re-energized when control power is restored and the timer will reset to zero and begin timing again.
- *Power Meter Controlled:* When an alarm condition assigned to the relay occurs, the relay is energized. The relay remains energized for the duration of the timer. When the timer expires, the relay will de-energize and remain de-energized. If the relay is on and the power meter loses control power, the relay will not be re-energized when control power is restored and the timer will reset to zero and begin timing again.

- **End Of Power Demand Interval**

This mode assigns the relay to operate as a synch pulse to another device. The output operates in timed mode using the timer setting and turns on at the end of a power demand interval. It turns off when the timer expires.

- **Absolute kWh Pulse**
This mode assigns the relay to operate as a pulse initiator with a user-defined number of kWh per pulse. In this mode, both forward and reverse real energy are treated as additive (as in a tie circuit breaker).
- **Absolute kVARh Pulse**
This mode assigns the relay to operate as a pulse initiator with a user-defined number of kVARh per pulse. In this mode, both forward and reverse reactive energy are treated as additive (as in a tie circuit breaker).
- **kVAh Pulse**
This mode assigns the relay to operate as a pulse initiator with a user-defined number of kVAh per pulse. Since kVA has no sign, the kVAh pulse has only one mode.
- **kWh In Pulse**
This mode assigns the relay to operate as a pulse initiator with a user-defined number of kWh per pulse. In this mode, only the kWh flowing into the load is considered.
- **kVARh In Pulse**
This mode assigns the relay to operate as a pulse initiator with a user-defined number of kVARh per pulse. In this mode, only the kVARh flowing into the load is considered.
- **kWh Out Pulse**
This mode assigns the relay to operate as a pulse initiator with a user-defined number of kWh per pulse. In this mode, only the kWh flowing out of the load is considered.
- **kVARh Out Pulse**
This mode assigns the relay to operate as a pulse initiator with a user-defined number of kVARh per pulse. In this mode, only the kVARh flowing out of the load is considered.

The last seven modes in the list above are for pulse initiator applications. All Series 800 Power Meters are equipped with one solid-state KY pulse output rated at 100 mA. The solid-state KY output provides the long life—billions of operations—required for pulse initiator applications.

The KY output is factory configured with Name = KY, Mode = Normal, and Control = External. To set up custom values, press SETUP > I/O. For detailed instructions, see “Set Up I/Os” on page 24. Then using

SMS, you must define the following values for each mechanical relay output:

- **Name**—A 16-character label used to identify the digital output.
- **Mode**—Select one of the operating modes listed above.
- **Pulse Weight**—You must set the pulse weight, the multiplier of the unit being measured, if you select any of the pulse modes (last 7 listed above).
- **Timer**—You must set the timer if you select the timed mode or end of power demand interval mode (in seconds).
- **Control**—You must set the relay to be controlled either remotely or internally (from the power meter) if you select the normal, latched, or timed mode.

For instructions on setting up digital I/Os in SMS, see the SMS online help on device set up of the power meter.

Solid-state KY Pulse Output

This section describes the pulse output capabilities of the power meter. For instructions on wiring the KY pulse output, see “Wiring the Solid-State KY Output” in Chapter 5—Wiring of the installation manual.

The power meter units are equipped with one onboard, solid-state KY pulse output. This solid-state relay provides the extremely long life—billions of operations—required for pulse initiator applications.

The KY output is a Form-A contact with a maximum rating of 100 mA. Because most pulse initiator applications feed solid-state receivers with low burdens, this 100 mA rating is adequate for most applications.

To set the kilowatt-hour-per-pulse value, use SMS or the display. When setting the kWh/pulse value, set the value based on a 2-wire pulse output. For instructions on calculating the correct value, see “Calculating the Kilowatt-hour-Per-Pulse Value” on page 69 in this chapter.

The KY pulse output can be configured to operate in one of 11 operating modes. See “Relay Output Operating Modes” on page 64 for a description of the modes.

2-wire Pulse Initiator

Figure 5–3 shows a pulse train from a 2-wire pulse initiator application.

Figure 5–3: Two-wire pulse train

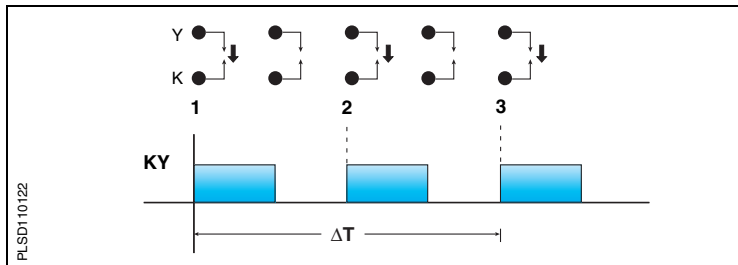

In Figure 5–3, the transitions are marked as 1 and 2. Each transition represents the time when the relay contact closes. Each time the relay transitions, the receiver counts a pulse. The power meter can deliver up to 12 pulses per second in a 2-wire application.

Calculating the Kilowatt-hour-Per-Pulse Value

This section shows an example of how to calculate kilowatt-hours per pulse. To calculate this value, first determine the highest kW value you can expect and the required pulse rate. In this example, the following assumptions are made:

- The metered load should not exceed 1600 kW.
- About two KY pulses per second should occur at full scale.

Step 1: Convert 1600 kW load into kWh/second.

$$(1600 \text{ kW})(1 \text{ Hr}) = 1600 \text{ kWh}$$

$$\frac{(1600 \text{ kWh})}{1 \text{ hour}} = \frac{X \text{ kWh}}{1 \text{ second}}$$

$$\frac{(1600 \text{ kWh})}{3600 \text{ seconds}} = \frac{X \text{ kWh}}{1 \text{ second}}$$

$$X = 1600/3600 = 0.444 \text{ kWh/second}$$

Step 2: Calculate the kWh required per pulse.

$$\frac{0.444 \text{ kWh/second}}{2 \text{ pulses/second}} = 0.2222 \text{ kWh/pulse}$$

Step 3: Adjust for the KY initiator (KY will give one pulse per two transitions of the relay).

$$\frac{0.2222 \text{ kWh/second}}{2} = 0.1111 \text{ kWh/pulse}$$

Step 4: Round to nearest hundredth, since the power meter only accepts 0.01 kWh increments.

$$K_e = 0.11 \text{ kWh/pulse}$$

Analog Inputs

With a PM8M2222 option module installed, a power meter can accept either voltage or current signals through the analog inputs on the option module. The Power Meter stores a minimum and a maximum value for each analog input.

For technical specifications and instructions on installing and configuring the analog inputs on the PM8M2222, refer to the instruction bulletin (63230-502-200) that ships with the option module. To set up an analog input, you must first set it up from the display. From the SUMMARY screen, select MAINT > SETUP > I/O, then select the appropriate analog input option. Then, in SMS define the following values for each analog input:

- **Name**—a 16-character label used to identify the analog input.
- **Units**—the units of the monitored analog value (for example, “psi”).
- **Scale factor**—multiplies the units by this value (such as tenths or hundredths).
- **Report Range Lower Limit**—the value the Power Meter reports when the input reaches a minimum value. When the input current is below the lowest valid reading, the Power Meter reports the lower limit.
- **Report Range Upper Limit**—the value the circuit monitor reports when the input reaches the maximum value. When the input current is above highest valid reading, the Power Meter reports the upper limit.

For instructions on setting up analog inputs in SMS, see device set up of the Power Meter in the SMS online Help.

Analog Outputs

This section describes the analog output capabilities when a PM8M2222 is installed on the Power Meter. For technical specifications and instructions on installing and configuring the analog outputs on the PM8M2222, refer to the instruction bulletin (63230-502-200) that ships with the option module.

To set up an analog output, you must first set it up from the display. From the SUMMARY screen, select MAINT > SETUP > I/O, then select the appropriate analog output option. Then, in SMS define the following values for each analog input

- **Name**—A 16-character label used to identify the output. Default names are assigned, but can be customized
- **Output register**—The Power Meter register assigned to the analog output.
- **Lower Limit**—The value equivalent to the minimum output current. When the register value is below the lower limit, the Power Meter outputs the minimum output current.
- **Upper Limit**—The value equivalent to the maximum output current. When the register value is above the upper limit, the Power Meter outputs the maximum output current.

For instructions on setting up an analog output in SMS, see the SMS online help on device set up of the Power Meter.

CHAPTER 6—ALARMS

This section describes the alarm features on the PM810 and the PM810 with a PM810LOG installed.

About Alarms

The power meter can detect over 50 alarm conditions, including over or under conditions, digital input changes, phase unbalance conditions, and more. It also maintains a counter for each alarm to keep track of the total number of occurrences. A complete list of default alarm configurations are described in Table 6–4 on page 84. In addition, you can set up your own custom alarms after installing an input/output module (PM8M22, PM8M26, or PM8M2222).

When one or more alarm conditions are true, the power meter will execute a task automatically. An **▲** alarm icon appears in the upper-right corner of the power meter display, indicating that an alarm is active. If a PM810LOG is installed on a PM810, SMS can be used to set up each alarm condition to force data log entries in a single data log file. See **Chapter 7—Logging** on page 89 for more information about data logging.

Table 6–1: Basic alarm features by model

Basic Alarm Feature	PM810	PM810 with PM810LOG
Standard alarms	33	33
Open slots for additional standard alarms	7 ^①	7 ^①
Digital	12 ^②	12 ^②
Custom alarms	Yes ^②	Yes ^②

① Available when an I/O module with analog IN/OUT is installed.

② Requires an input/output option module (PM8M22, PM8M26, or the PM8M2222).

Alarm Groups

When using a default alarm, you first choose the alarm group that is appropriate for the application. Each alarm condition is assigned to one of these alarm groups:

- **Standard**—Standard alarms have a detection rate of 1 second and are useful for detecting conditions such as over current and under voltage. Up to 40 alarms can be set up in this alarm group.
- **Digital**—Digital alarms are triggered by an exception such as the transition of a digital input or the end of an incremental energy interval. Up to 12 alarms can be set up in this group.
- **Custom**—The power meter has many pre-defined alarms, but you can also set up your own custom alarms using SMS. For example, you may need to alarm on the ON-to-OFF transition of a digital input. To create this type of custom alarm:
 1. Select the appropriate alarm group (digital in this case).
 2. Select the type of alarm (described in Table 6–5 on page 85).
 3. Give the alarm a name.
 4. Save the custom alarm.

After creating a custom alarm, you can configure it by applying priorities, setting pickups and dropouts (if applicable), and so forth.

SMS and the Power Meter display can be used to setup standard, digital, and custom alarm types.

Setpoint-driven Alarms

Many of the alarm conditions require that you define setpoints. This includes all alarms for over, under, and phase unbalance alarm conditions. Other alarm conditions such as digital input transitions and phase reversals do not require setpoints. For those alarm conditions that require setpoints, you must define the following information:

- Pickup Setpoint
- Pickup Delay
- Dropout Setpoint
- Dropout Delay

NOTE: Alarms with both Pickup and Dropout setpoints set to zero are invalid.

To understand how the power meter handles setpoint-driven alarms, see Figure 6–2 on page 76. Figure 6–1 shows what the actual alarm Log entries for Figure 6–2 might look like, as displayed by SMS.

NOTE: The software does not actually display the codes in parentheses—EV1, EV2, Max1, Max2. These are references to the codes in Figure 6–2.

Figure 6–1: Sample alarm log entry

Time	Device	Type	Function	Value	State	Level
11/14/2005 5:16:34.996 PM	PM870 Office	0	Swell lb	690	Voltage/Current Swell Dropout	3
11/14/2005 5:16:34.987 PM	PM870 Office	0	Swell la	690	Voltage/Current Swell Dropout	2
11/14/2005 5:16:31.297 PM	PM870 Office	0	Swell la	685	Voltage/Current Swell Pickup	2
11/14/2005 5:16:31.181 PM	PM870 Office	0	Swell la	651	Voltage/Current Swell Dropout	2
11/14/2005 5:16:31.031 PM	PM870 Office	0	Swell la	670	Voltage/Current Swell Pickup	2
11/14/2005 5:16:30.997 PM	PM870 Office	0	Swell lb	653	Voltage/Current Swell Pickup	3
11/14/2005 5:16:28.404 PM	PM870 Office	0	Swell lb	674	Voltage/Current Swell Dropout	3

Annotations in the image:
- EV2 points to the 'Value' column of the first row (690).
- EV1 points to the 'Value' column of the second row (690).
- Max2 points to the 'Value' column of the third row (685).
- Max1 points to the 'Value' column of the fourth row (651).

Figure 6–2: How the power meter handles setpoint-driven alarms

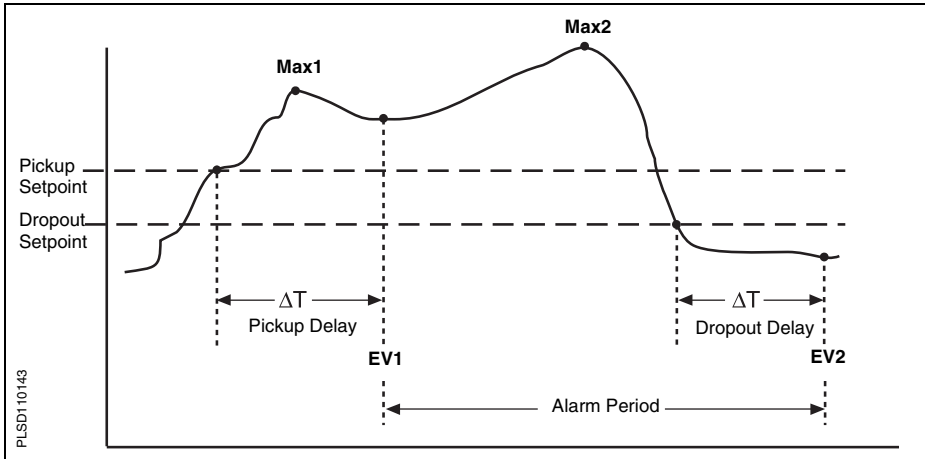

EV1—The power meter records the date and time that the pickup setpoint and time delay were satisfied, and the maximum value reached (Max1) during the pickup delay period (ΔT). Also, the power meter performs any tasks assigned to the event such as waveform captures or forced data log entries.

EV2—The power meter records the date and time that the dropout setpoint and time delay were satisfied, and the maximum value reached (Max2) during the alarm period.

The power meter also stores a correlation sequence number (CSN) for each event (such as *Under Voltage Phase A Pickup*, *Under Voltage Phase A Dropout*). The CSN lets you relate pickups and dropouts in the alarm log. You can sort pickups and dropouts by CSN to correlate the pickups and dropouts of a particular alarm. The pickup and dropout entries of an alarm will have the same CSN. You can also calculate the duration of an event by looking at pickups and dropouts with the same CSN.

Priorities

Each alarm also has a priority level. Use the priorities to distinguish between events that require immediate action and those that do not require action.

- **High priority**—if a high priority alarm occurs, the display informs you in two ways: the LED backlight on the display flashes until you acknowledge the alarm and the alarm icon blinks while the alarm is active.
- **Medium priority**—if a medium priority alarm occurs, the alarm icon blinks only while the alarm is active. Once the alarm becomes inactive, the alarm icon stops blinking and remains on the display.
- **Low priority**—if a low priority alarm occurs, the alarm icon blinks only while the alarm is active. Once the alarm becomes inactive, the alarm icon disappears from the display.
- **No priority**—if an alarm is setup with no priority, no visible representation will appear on the display. Alarms with no priority are not entered in the Alarm Log. See **Chapter 7—Logging** for alarm logging information.

If multiple alarms with different priorities are active at the same time, the display shows the alarm message for the last alarm that occurred. For instructions on setting up alarms from the power meter display, see “Set Up Alarms” on page 23.

Viewing Alarm Activity and History

1. Press **←** until ALARM is visible.
2. Press ALARM.
3. View the active alarm listed on the power meter display. If there are no active alarms, the screen reads, “NO ACTIVE ALARMS.”
4. If there are active alarms, press **←** or **→** to view a different alarm.
5. Press HIST.
6. Press **←** or **→** to view a different alarm’s history.
7. Press **↑** to return to the SUMMARY screen.

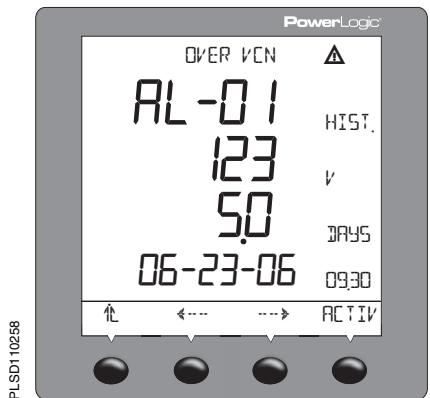

Types of Setpoint-controlled Functions

This section describes some common alarm functions to which the following information applies:

- Values that are too large to fit into the display may require scale factors. For more information on scale factors, refer to “Changing Scale Factors” on page 193.
- Relays can be configured as normal, latched, or timed. See “Relay Output Operating Modes” on page 64 in **Chapter 5—Input/Output Capabilities** for more information.
- When the alarm occurs, the power meter operates any specified relays. There are two ways to release relays that are in latched mode:
 - Issue a command to de-energize a relay. See **Appendix B—Using the Command Interface** for instructions on using the command interface, or
 - Acknowledge the alarm in the high priority log to release the relays from latched mode. From the main menu of the display, press ALARM to view and acknowledge unacknowledged alarms.

The list that follows shows the types of alarms available for some common alarm functions:

NOTE: Voltage based alarm setpoints depend on your system configuration. Alarm setpoints for 3-wire systems are V_{L-L} values while 4-wire systems are V_{L-N} values.

Undervoltage: Pickup and dropout setpoints are entered in volts. The per-phase undervoltage alarm occurs when the per-phase voltage is equal to or below the pickup setpoint long enough to satisfy the specified pickup delay (in seconds). The undervoltage alarm clears when the phase voltage remains above the dropout setpoint for the specified dropout delay period.

Overvoltage: Pickup and dropout setpoints are entered in volts. The per-phase overvoltage alarm occurs when the per-phase voltage is equal to or above the pickup setpoint long enough to satisfy the specified pickup delay (in seconds). The overvoltage alarm clears when the phase voltage remains below the dropout setpoint for the specified dropout delay period.

Unbalance Current: Pickup and dropout setpoints are entered in tenths of percent, based on the percentage difference between each

phase current with respect to the average of all phase currents. For example, enter an unbalance of 7% as 70. The unbalance current alarm occurs when the phase current deviates from the average of the phase currents, by the percentage pickup setpoint, for the specified pickup delay. The alarm clears when the percentage difference between the phase current and the average of all phases remains below the dropout setpoint for the specified dropout delay period.

Unbalance Voltage: Pickup and dropout setpoints are entered in tenths of percent, based on the percentage difference between each phase voltage with respect to the average of all phase voltages. For example, enter an unbalance of 7% as 70. The unbalance voltage alarm occurs when the phase voltage deviates from the average of the phase voltages, by the percentage pickup setpoint, for the specified pickup delay. The alarm clears when the percentage difference between the phase voltage and the average of all phases remains below the dropout setpoint for the specified dropout delay (in seconds).

Phase Loss—Current: Pickup and dropout setpoints are entered in amperes. The phase loss current alarm occurs when any current value (but not all current values) is equal to or below the pickup setpoint for the specified pickup delay (in seconds). The alarm clears when one of the following is true:

- All of the phases remain above the dropout setpoint for the specified dropout delay, or
- All of the phases drop below the phase loss pickup setpoint.

If all of the phase currents are equal to or below the pickup setpoint, during the pickup delay, the phase loss alarm will not activate. This is considered an under current condition. It should be handled by configuring the under current alarm functions.

Phase Loss—Voltage: Pickup and dropout setpoints are entered in volts. The phase loss voltage alarm occurs when any voltage value (but not all voltage values) is equal to or below the pickup setpoint for the specified pickup delay (in seconds). The alarm clears when one of the following is true:

- All of the phases remain above the dropout setpoint for the specified dropout delay (in seconds), OR
- All of the phases drop below the phase loss pickup setpoint.

If all of the phase voltages are equal to or below the pickup setpoint, during the pickup delay, the phase loss alarm will not activate. This is considered an under voltage condition. It should be handled by configuring the under voltage alarm functions.

Reverse Power: Pickup and dropout setpoints are entered in kilowatts or kVARs. The reverse power alarm occurs when the power flows in a negative direction and remains at or below the negative pickup value for the specified pickup delay (in seconds). The alarm clears when the power reading remains above the dropout setpoint for the specified dropout delay (in seconds).

Phase Reversal: Pickup and dropout setpoints and delays do not apply to phase reversal. The phase reversal alarm occurs when the phase voltage rotation differs from the default phase rotation. The power meter assumes that an ABC phase rotation is normal. If a CBA phase rotation is normal, the user must change the power meter's phase rotation from ABC (default) to CBA. To change the phase rotation from the display, from the main menu select Setup > Meter > Advanced. For more information about changing the phase rotation setting of the power meter, refer to "Advanced Power Meter Setup Options" on page 26.

Scale Factors

A scale factor is the multiplier expressed as a power of 10. For example, a multiplier of 10 is represented as a scale factor of 1, since $10^1=10$; a multiplier of 100 is represented as a scale factor of 2, since $10^2=100$. This allows you to make larger values fit into the register. Normally, you do not need to change scale factors. If you are creating custom alarms, you need to understand how scale factors work so that you do not overflow the register with a number larger than what the register can hold. When SMS is used to set up alarms, it automatically handles the scaling of pickup and dropout setpoints. When creating a custom alarm using the power meter's display, do the following:

- Determine how the corresponding metering value is scaled, and
- Take the scale factor into account when entering alarm pickup and dropout settings.

Pickup and dropout settings must be integer values in the range of -32,767 to +32,767. For example, to set up an under voltage alarm for a 138 kV nominal system, decide upon a setpoint value and then convert it into an integer between -32,767 and +32,767. If the under voltage setpoint were 125,000 V, this would typically be converted to 12500×10 and entered as a setpoint of 12500.

Six scale groups are defined (A through F). The scale factor is preset for all factory-configured alarms. Table 6–2 on page 82 lists the available scale factors for each of the scale groups. If you need either an extended range or more resolution, select any of the available scale factors to suit your need. Refer to “Changing Scale Factors” on page 193 of **Appendix B—Using the Command Interface**.

Table 6–2: Scale Groups

Scale Group	Measurement Range	Scale Factor
Scale Group A—Phase Current	Amperes	
	0–327.67 A	–2
	0–3,276.7 A	–1
	0–32,767 A	0 (default)
	0–327.67 kA	1
Scale Group B—Neutral Current	Amperes	
	0–327.67 A	–2
	0–3,276.7 A	–1
	0–32,767 A	0 (default)
	0–327.67 kA	1
Scale Group D—Voltage	Voltage	
	0–3,276.7 V	–1
	0–32,767 V	0 (default)
	0–327.67 kV	1
	0–3,276.7 kV	2
Scale Group F—Power kW, kVAR, kVA	Power	
	0–32.767 kW, kVAR, kVA	–3
	0–327.67 kW, kVAR, kVA	–2
	0–3,276.7 kW, kVAR, kVA	–1
	0–32,767 kW, kVAR, kVA	0 (default)
	0–327.67 MW, MVAR, MVA	1
	0–3,276.7 MW, MVAR, MVA	2
	0–32,767 MW, MVAR, MVA	3

Scaling Alarm Setpoints

This section is for users who do not have SMS and must set up alarms from the power meter display. It explains how to scale alarm setpoints.

When the power meter is equipped with a display, most metered quantities are limited to five characters (plus a positive or negative sign). The display will also show the engineering units applied to that quantity.

To determine the proper scaling of an alarm setpoint, view the register number for the associated scale group. The scale factor is the number in the Dec column for that register. For example, the register number for Scale D to Phase Volts is 3212. If the number in the Dec column is 1, the scale factor is 10 ($10^1=10$). Remember that scale factor 1 in Table 6–3 on page 83 for Scale Group D is measured in kV. Therefore, to define an alarm setpoint of 125 kV, enter 12.5 because 12.5 multiplied by 10 is 125. Below is a table listing the scale groups and their register numbers.

Table 6–3: Scale Group Register Numbers

Scale Group	Register Number
Scale Group A—Phase Current	3209
Scale Group B—Neutral Current	3210
Scale Group C—Ground Current	3211
Scale Group D—Voltage	3212
Scale Group F—Power kW, kVAR, kVA	3214

Alarm Conditions and Alarm Numbers

This section lists the power meter's predefined alarm conditions. For each alarm condition, the following information is provided.

- **Alarm No.**—a position number indicating where an alarm falls in the list.
- **Alarm Description**—a brief description of the alarm condition
- **Abbreviated Display Name**—an abbreviated name that describes the alarm condition, but is limited to 15 characters that fit in the window of the power meter's display.
- **Test Register**—the register number that contains the value (where applicable) that is used as the basis for a comparison to alarm pickup and dropout settings.
- **Units**—the unit that applies to the pickup and dropout settings.

- **Scale Group**—the scale group that applies to the test register’s metering value (A–F). For a description of scale groups, see “Scale Factors” on page 81.
- **Alarm Type**—a reference to a definition that provides details on the operation and configuration of the alarm. For a description of alarm types, refer to Table 6–5 on page 85.

Table 6–4 on page 84 lists the preconfigured alarms by alarm number. Table 6–5 on page 87 lists the default alarm configurations.

Table 6–4: List of Default Basic Alarms by Alarm Number

Alarm Number	Alarm Description	Abbreviated Display Name	Test Register	Units	Scale Group ^①	Alarm Type ^②
Standard Speed Alarms (1 Second)						
01	Over Current Phase A	Over Ia	1100	Amperes	A	010
02	Over Current Phase B	Over Ib	1101	Amperes	A	010
03	Over Current Phase C	Over Ic	1102	Amperes	A	010
04	Over Current Neutral	Over In	1103	Amperes	B	010
05	Current Unbalance, Max	I Unbal Max	1110	Tenths %	—	010
06	Current Loss	Current Loss	3262	Amperes	A	053
07	Over Voltage Phase A–N	Over Van	1124	Volts	D	010
08	Over Voltage Phase B–N	Over Vbn	1125	Volts	D	010
09	Over Voltage Phase C–N	Over Vcn	1126	Volts	D	010
10	Over Voltage Phase A–B	Over Vab	1120	Volts	D	010
11	Over Voltage Phase B–C	Over Vbc	1121	Volts	D	010
12	Over Voltage Phase C–A	Over Vca	1122	Volts	D	010
13	Under Voltage Phase A	Under Van	1124	Volts	D	020
14	Under Voltage Phase B	Under Vbn	1125	Volts	D	020
15	Under Voltage Phase C	Under Vcn	1126	Volts	D	020
16	Under Voltage Phase A–B	Under Vab	1120	Volts	D	020
17	Under Voltage Phase B–C	Under Vbc	1121	Volts	D	020
18	Under Voltage Phase C–A	Under Vca	1122	Volts	D	020
19	Voltage Unbalance L–N, Max	V Unbal L–N Max	1136	Tenths %	—	010
20	Voltage Unbalance L–L, Max	V Unbal L–L Max	1132	Tenths %	—	010
21	Voltage Loss (loss of A,B,C, but not all)	Voltage Loss	3262	Volts	D	052
22	Phase Reversal	Phase Rev	3228	—	—	051
23	Over kW Demand	Over kW Dmd	2151	kW	F	011

① Scale groups are described in Table 6–2 on page 82.

② Alarm types are described in Table 6–5 on page 85.

③ Additional analog and digital alarms require a corresponding I/O module to be installed.

Table 6–4: List of Default Basic Alarms by Alarm Number

Alarm Number	Alarm Description	Abbreviated Display Name	Test Register	Units	Scale Group ^①	Alarm Type ^②
24	Lagging true power factor	Lag True PF	1163	Thousandths	—	055
25	Over THD of Voltage Phase A–N	Over THD Van	1207	Tenths %		
26	Over THD of Voltage Phase B–N	Over THD Vbn	1208	Tenths %		
27	Over THD of Voltage Phase C–N	Over THD Vcn	1209	Tenths %		
28	Over THD of Voltage Phase A–B	Over THD Vab	1211	Tenths %		
29	Over THD of Voltage Phase B–C	Over THD Vbc	1212	Tenths %		
30	Over THD of Voltage Phase C–A	Over THD Vca	1213	Tenths %		
31	Over kVA Demand	Over kVA Dmd	2181			
32	Over kW Total	Over kW Total	1143			
33	Over kVA Total	Over kVA Total	1151			
34-40	Reserved for additional analog alarms ^③	—	—	—	—	—
Digital						
01	End of incremental energy interval	End Inc Enr Int	N/A	—	—	070
02	End of power demand interval	End Dmd Int	N/A	—	—	070
03	Power up/Reset	Pwr Up/Reset	N/A	—	—	070
04	Digital Input OFF/ON	DIG IN S02	2	—	—	060
05-12	Reserved for additional digital alarms ^③	—	—	—	—	—

① Scale groups are described in Table 6–2 on page 82.

② Alarm types are described in Table 6–5 on page 85.

③ Additional analog and digital alarms require a corresponding I/O module to be installed.

Table 6–5: Alarm Types

Type	Description	Operation
Standard Speed		
010	Over Value Alarm	If the test register value exceeds the setpoint long enough to satisfy the pickup delay period, the alarm condition will be true. When the value in the test register falls below the dropout setpoint long enough to satisfy the dropout delay period, the alarm will dropout. Pickup and dropout setpoints are positive, delays are in seconds.
011	Over Power Alarm	If the absolute value in the test register exceeds the setpoint long enough to satisfy the pickup delay period, the alarm condition will be true. When absolute the value in the test register falls below the dropout setpoint long enough to satisfy the dropout delay period, the alarm will dropout. Pickup and dropout setpoints are positive, delays are in seconds.

Table 6–5: Alarm Types

Type	Description	Operation
012	Over Reverse Power Alarm	If the absolute value in the test register exceeds the setpoint long enough to satisfy the pickup delay period, the alarm condition will be true. When absolute the value in the test register falls below the dropout setpoint long enough to satisfy the dropout delay period, the alarm will dropout. This alarm will only hold true for reverse power conditions. Positive power values will not cause the alarm to occur. Pickup and dropout setpoints are positive, delays are in seconds.
020	Under Value Alarm	If the test register value is below the setpoint long enough to satisfy the pickup delay period, the alarm condition will be true. When the value in the test register rises above the dropout setpoint long enough to satisfy the dropout delay period, the alarm will dropout. Pickup and dropout setpoints are positive, delays are in seconds.
021	Under Power Alarm	If the absolute value in the test register is below the setpoint long enough to satisfy the pickup delay period, the alarm condition will be true. When the absolute value in the test register rises above the dropout setpoint long enough to satisfy the dropout delay period, the alarm will dropout. Pickup and dropout setpoints are positive, delays are in seconds.
051	Phase Reversal	The phase reversal alarm will occur whenever the phase voltage waveform rotation differs from the default phase rotation. The ABC phase rotation is assumed to be normal. If a CBA phase rotation is normal, the user should reprogram the power meter's phase rotation ABC to CBA phase rotation. The pickup and dropout setpoints and delays for phase reversal do not apply.
052	Phase Loss, Voltage	The phase loss voltage alarm will occur when any one or two phase voltages (but not all) fall to the pickup value and remain at or below the pickup value long enough to satisfy the specified pickup delay. When all of the phases remain at or above the dropout value for the dropout delay period, or when all of the phases drop below the specified phase loss pickup value, the alarm will dropout. Pickup and dropout setpoints are positive, delays are in seconds.
053	Phase Loss, Current	The phase loss current alarm will occur when any one or two phase currents (but not all) fall to the pickup value and remain at or below the pickup value long enough to satisfy the specified pickup delay. When all of the phases remain at or above the dropout value for the dropout delay period, or when all of the phases drop below the specified phase loss pickup value, the alarm will dropout. Pickup and dropout setpoints are positive, delays are in seconds.
054	Leading Power Factor	The leading power factor alarm will occur when the test register value becomes more leading than the pickup setpoint (such as closer to 0.010) and remains more leading long enough to satisfy the pickup delay period. When the value becomes equal to or less leading than the dropout setpoint, that is 1.000, and remains less leading for the dropout delay period, the alarm will dropout. Both the pickup setpoint and the dropout setpoint must be positive values representing leading power factor. Enter setpoints as integer values representing power factor in thousandths. For example, to define a dropout setpoint of 0.5, enter 500. Delays are in seconds.

Table 6–5: Alarm Types

Type	Description	Operation
055	Lagging Power Factor	The lagging power factor alarm will occur when the test register value becomes more lagging than the pickup setpoint (such as closer to –0.010) and remains more lagging long enough to satisfy the pickup delay period. When the value becomes equal to or less lagging than the dropout setpoint and remains less lagging for the dropout delay period, the alarm will dropout. Both the pickup setpoint and the dropout setpoint must be positive values representing lagging power factor. Enter setpoints as integer values representing power factor in thousandths. For example, to define a dropout setpoint of –0.5, enter 500. Delays are in seconds.
Digital		
060	Digital Input On	The digital input transition alarms will occur whenever the digital input changes from off to on. The alarm will dropout when the digital input changes back to off from on. The pickup and dropout setpoints and delays do not apply.
061	Digital Input Off	The digital input transition alarms will occur whenever the digital input changes from on to off. The alarm will dropout when the digital input changes back to on from off. The pickup and dropout setpoints and delays do not apply.
070	Unary	This is a internal signal from the power meter and can be used, for example, to alarm at the end of an interval or when the power meter is reset. Neither the pickup and dropout delays nor the setpoints apply.

Table 6–5: Default Alarm Configuration - Factory-enabled Alarms

Alarm No.	Standard Alarm	Pickup Limit	Pickup Limit Time Delay	Dropout Limit	Dropout Limit Time Delay
19	Voltage Unbalance L-N	20 (2.0%)	300	20 (2.0%)	300
20	Max. Voltage Unbalance L-L	20 (2.0%)	300	20 (2.0%)	300
53	End of Incremental Energy Interval	0	0	0	0
55	Power-up Reset	0	0	0	0

CHAPTER 7—LOGGING

Introduction

This chapter briefly describes the following logs of the power meter:

- Alarm log
- Maintenance log
- Billing log
- User-defined data logs

See the table below for a summary of logs supported by each power meter model.

Table 7-1: Number of logs supported by model

Log Type	Number of Logs Per Model	
	PM810	PM810 with PM810LOG
Alarm Log	1	1
Maintenance Log	1	1
Billing Log	—	1
Data Log 1	—	1

Logs are files stored in the nonvolatile memory of the power meter and are referred to as “onboard logs.” The amount of memory available depends on the model (see Table 8-2). Data and billing log files are preconfigured at the factory. You can accept the preconfigured logs or change them to meet your specific needs. Use SMS to set up and view all the logs. See the SMS online Help for information about working with the power meter’s onboard logs.

Power Meter Model	Total Memory Available
PM810	0 KB
PM810 with PM810LOG	80 KB

Refer to “Memory Allocation for Log Files” for information about memory allocation in the power meter.

Memory Allocation for Log Files

Each file in the power meter has a maximum memory size. Memory is not shared between the different logs, so reducing the number of values recorded in one log will not allow more values to be stored in a different log. The following table lists the memory allocated to each log:

Table 7–2: Memory Allocation for Each Log

Log Type	Max. Records Stored	Max. Register Values Recorded	Storage (Bytes)	Power Meter Model
Alarm Log	100	11	2,200	All models
Maintenance Log	40	4	320	All models
Billing Log	5000	96 + 3 D/T	65,536	PM810 with PM810LOG
Data Log 1	5000	96 + 3 D/T	14,808	PM810 with PM810LOG

Alarm Log

By default, the power meter can log the occurrence of any alarm condition. Each time an alarm occurs it is entered into the alarm log. The alarm log in the power meter stores the pickup and dropout points of alarms along with the date and time associated with these alarms. You select whether the alarm log saves data as first-in-first-out (FIFO) or fill and hold. With SMS, you can view and save the alarm log to disk, and reset the alarm log to clear the data out of the power meter's memory.

Alarm Log Storage

The power meter stores alarm log data in nonvolatile memory. The size of the alarm log is fixed at 100 records.

Maintenance Log

The power meter stores a maintenance log in nonvolatile memory. The file has a fixed record length of four registers and a total of 40 records. The first register is a cumulative counter over the life of the power meter. The last three registers contain the date/time of when the log was updated. Table 7–3 describes the values stored in the maintenance log. These values are cumulative over the life of the power meter and cannot be reset.

NOTE: Use SMS to view the maintenance log. Refer to the SMS online help for instructions.

Table 7–3: Values Stored in the Maintenance Log

Record Number	Value Stored
1	Time stamp of the last change
2	Date and time of the last power failure
3	Date and time of the last firmware download
4	Date and time of the last option module change
5	Date and time of the latest LVC update due to configuration errors detected during meter initialization
6–11	Reserved
12	Date and time the Present Month Min/Max was last reset
13	Date and time the Previous Month Min/Max was last reset
14	Date and time the Energy Pulse Output was overdriven

① Additional outputs require option modules and are based on the I/O configuration of that particular module.

Table 7–3: Values Stored in the Maintenance Log

Record Number	Value Stored
15	Date and time the Power Demand Min/Max was last reset
16	Date and time the Current Demand Min/Max was last reset
17	Date and time the Generic Demand Min/Max was last reset
18	Date and time the Input Demand Min/Max was last reset
19	Reserved
20	Date and time the Accumulated Energy value was last reset
21	Date and time the Conditional Energy value was last reset
22	Date and time the Incremental Energy value was last reset
23	Reserved
24	Date and time of the last Standard KY Output operation
25	Date and time of the last Discrete Output @A01 operation ^①
26	Date and time of the last Discrete Output @A02 operation ^①
27	Date and time of the last Discrete Output @A03 operation ^①
28	Date and time of the last Discrete Output @A04 operation ^①
29	Date and time of the last Discrete Output @A05 operation ^①
30	Date and time of the last Discrete Output @A06 operation ^①
31	Date and time of the last Discrete Output @A07 operation ^①
32	Date and time of the last Discrete Output @A08 operation ^①
33	Date and time of the last Discrete Output @B01 operation ^①
34	Date and time of the last Discrete Output @B02 operation ^①
35	Date and time of the last Discrete Output @B03 operation ^①
36	Date and time of the last Discrete Output @B04 operation ^①
37	Date and time of the last Discrete Output @B05 operation ^①
38	Date and time of the last Discrete Output @B06 operation ^①
39	Date and time of the last Discrete Output @B07 operation ^①
40	Date and time of the last Discrete Output @B08 operation ^①

^① Additional outputs require option modules and are based on the I/O configuration of that particular module.

Data Logs

The PM810 with a PM810LOG records and stores readings at regularly scheduled intervals in one independent data log. This log is preconfigured at the factory. You can accept the preconfigured data log or change it to meet your specific needs. You can set up the data log to store the following information:

- Timed Interval—1 second to 24 hours for Data Log 1
- First-In-First-Out (FIFO) or Fill and Hold
- Values to be logged—up to 96 registers along with the date and time of each log entry
- START/STOP Time—each log has the ability to start and stop at a certain time during the day

The default registers for Data Log 1 are listed in Table 7–4 below.

Table 7–4: Default Data Log 1 Register List

Description	Number of Registers	Data Type ^①	Register Number
Start Date/Time	3	D/T	Current D/T
Current, Phase A	1	integer	1100
Current, Phase B	1	integer	1101
Current, Phase C	1	integer	1102
Current, Neutral	1	integer	1103
Voltage A-B	1	integer	1120
Voltage B-C	1	integer	1121
Voltage C-A	1	integer	1122
Voltage A-N	1	integer	1124
Voltage B-N	1	integer	1125
Voltage C-N	1	integer	1126
True Power Factor, Phase A	1	signed integer	1160
True Power Factor, Phase B	1	signed integer	1161
True Power Factor, Phase C	1	signed integer	1162
True Power Factor, Total	1	signed integer	1163
Last Demand, Current, 3-Phase Average	1	integer	2000
Last Demand, Real Power, 3-Phase Total	1	integer	2150
Last Demand, Reactive Power, 3-Phase Total	1	integer	2165
Last Demand, Apparent Power 3-Phase Total	1	integer	2180

^① Refer to Appendix A for more information about data types.

Use SMS to clear each data log file, independently of the others, from the power meter’s memory. For instructions on setting up and clearing data log files, refer to the SMS online help file.

Alarm-driven Data Log Entries

The PM810 with a PM810LOG can detect over 50 alarm conditions, including over/under conditions, digital input changes, phase unbalance conditions, and more. (See **Chapter 6—Alarms** on page 73 for more information.) Use SMS to assign each alarm condition one or more tasks, including forcing data log entries into Data Log 1.

Billing Log

The PM810 with a PM810LOG stores a configurable billing log that updates every 10 to 1,440 minutes (the default interval 60 minutes). Data is stored by month, day, and the specified interval in minutes. The log contains 24 months of monthly data and 32 days of daily data, but because the maximum amount of memory for the billing log is 64 KB, the number of recorded intervals varies based on the number of registers recorded in the billing log. For example, using all of the registers listed in Table 7–5, the billing log holds 12 days of data at 60-minute intervals. This value is calculated by doing the following:

1. Calculate the total number of registers used (see Table 7–5 on page 96 for the number of registers). In this example, all 26 registers are used.
2. Calculate the number of bytes used for the 24 monthly records.
24 records (26 registers x 2 bytes/register) = 1,248
3. Calculate the number of bytes used for the 32 daily records.
 $32 (26 \times 2) = 1,664$
4. Calculate the number of bytes used each day.
 $96 (26 \times 2) = 4,992$
5. Calculate the number of days of 60-minute interval data recorded by subtracting the values from steps 2 and 3 from the total log file size of 65,536 bytes and then dividing by the value in step 4.
 $(65,536 - 1,248 - 1,664) \div 4,992 = 12$ days

Table 7–5: Billing Log Register List

Description	Number of Registers	Data Type ^①	Register Number
Start Date/Time	3	D/T	Current D/T
Real Energy In	4	MOD10L4	1700
Reactive Energy In	4	MOD10L4	1704
Real Energy Out	4	MOD10L4	1708
Reactive Energy Out	4	MOD10L4	1712
Apparent Energy Total	4	MOD10L4	1724
Total PF	1	INT16	1163
3P Real Power Demand	1	INT16	2151
3P Apparent Power Demand	1	INT16	2181

① Refer to Appendix A for more information about data types.

Configure the Billing Log Logging Interval

The billing log can be configured to update every 10 to 1,440 minutes. The default logging interval is 60 minutes. To set the logging interval you can use SMS (see the SMS online Help for setup details) or you can use the power meter to write the logging interval to register 3085 (see “Read and Write Registers” on page 36).

CHAPTER 8—MAINTENANCE AND TROUBLESHOOTING

Introduction

This chapter describes information related to maintenance of your power meter.

The power meter does not contain any user-serviceable parts. If the power meter requires service, contact your local sales representative. Do not open the power meter. Opening the power meter voids the warranty.

DANGER

HAZARD OF ELECTRIC SHOCK, EXPLOSION, OR ARC FLASH

- Do not attempt to service the power meter. CT and PT inputs may contain hazardous currents and voltages.
- Only authorized service personnel from the manufacturer should service the power meter.

Failure to follow this instruction will result in death or serious injury.

CAUTION

HAZARD OF EQUIPMENT DAMAGE

- Do not perform a Dielectric (Hi-Pot) or Megger test on the power meter. High voltage testing of the power meter may damage the unit.
- Before performing Hi-Pot or Megger testing on any equipment in which the power meter is installed, disconnect all input and output wires to the power meter.

Failure to follow this instruction can result in injury or equipment damage.

Power Meter Memory

The power meter uses its nonvolatile memory (RAM) to retain all data and metering configuration values. Under the operating temperature range specified for the power meter, this nonvolatile memory has an expected life of up to 100 years. The power meter stores its data logs on a memory chip, which has a life expectancy of up to 20 years under the operating temperature range specified for the power meter. For the PM810 with a PM810LOG, the life of the internal battery-backed clock is over 10 years at 25°C.

NOTE: Life expectancy is a function of operating conditions; this does not constitute any expressed or implied warranty.

Date and Time Settings

The clock in the PM810 is volatile. Therefore, the PM810 returns to the default clock date/time of 12:00 AM 01-01-1980 each time the meter resets. Reset occurs when the meter loses control power or you change meter configuration parameters including selecting the time format (24-hr or AM/PM) or date format. To avoid resetting clock time more than once, always set the clock date and time last. The PM810LOG (optional module) provides a nonvolatile clock in addition to onboard logging and individual harmonics readings for the PM810.

Identifying the Firmware Version, Model, and Serial Number

1. From the first menu level, press \rightarrow until MAINT is visible.
2. Press DIAG.
3. Press METER.
4. View the model, firmware (OS) version, and serial number.
5. Press \uparrow to return to the MAINTENANCE screen.

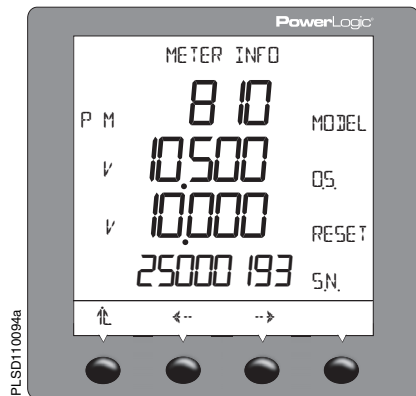

Viewing the Display in Different Languages

The power meter can be set to use one of three different languages: English, French, and Spanish. Other languages are available. Please contact your local sales representative for more information about other language options.

The power meter language can be selected by doing the following:

1. From the first menu level, press \rightarrow until MAINT is visible.
2. Press MAINT.
3. Press SETUP.
4. Enter your password, then press OK.
5. Press \rightarrow until LANG is visible.
6. Press LANG.
7. Select the language: ENGL (English), SPAN (Spanish), FREN (French), GERMN (German), or RUSSN (Russian).
8. Press OK.
9. Press \uparrow .
10. Press YES to save your changes.



Technical Support

Please refer to the *Technical Support Contacts* provided in the power meter shipping carton for a list of support phone numbers by country.

Troubleshooting

The information in Table 8–1 on page 103 describes potential problems and their possible causes. It also describes checks you can perform or possible solutions for each. After referring to this table, if you cannot resolve the problem, contact the your local Square D/Schneider Electric sales representative for assistance.

DANGER

HAZARD OF ELECTRIC SHOCK, EXPLOSION, OR ARC FLASH

- Apply appropriate personal protective equipment (PPE) and follow safe electrical practices. For example, in the United States, see NFPA 70E.
- This equipment must be installed and serviced only by qualified personnel.
- Turn off all power supplying this equipment before working on or inside.
- Always use a properly rated voltage sensing device to confirm that all power is off.
- Carefully inspect the work area for tools and objects that may have been left inside the equipment.
- Use caution while removing or installing panels so that they do not extend into the energized bus; avoid handling the panels, which could cause personal injury.

Failure to follow this instruction will result in death or serious injury.

Heartbeat LED

The heartbeat LED helps to troubleshoot the power meter. The LED works as follows:

- **Normal operation** — the LED flashes at a steady rate during normal operation.
- **Communications** — the LED flash rate changes as the communications port transmits and receives data. If the LED flash rate does not change when data is sent from the host computer, the power meter is not receiving requests from the host computer.
- **Hardware** — if the heartbeat LED remains lit and does not flash ON and OFF, there is a hardware problem. Do a hard reset of the power meter (turn OFF power to the power meter, then restore power to the power meter). If the heartbeat LED remains lit, contact your local sales representative.
- **Control power and display** — if the heartbeat LED flashes, but the display is blank, the display is not functioning properly. If the display is blank and the LED is not lit, verify that control power is connected to the power meter.

Table 8–1: Troubleshooting

Potential Problem	Possible Cause	Possible Solution
The maintenance icon is illuminated on the power meter display.	When the maintenance icon is illuminated, it indicates a potential hardware or firmware problem in the power meter.	When the maintenance icon is illuminated, go to DIAGNOSTICS > MAINTENANCE. Error messages display to indicate the reason the icon is illuminated. Note these error messages and call Technical Support or contact your local sales representative for assistance.
The display shows error code 3.	Loss of control power or meter configuration has changed.	Set date and time.
The display is blank after applying control power to the power meter.	The power meter may not be receiving the necessary power.	<ul style="list-style-type: none">• Verify that the power meter line (L) and neutral (N) terminals (terminals 25 and 27) are receiving the necessary power.• Verify that the heartbeat LED is blinking.• Check the PLSD110074.

Table 8–1: Troubleshooting

Potential Problem	Possible Cause	Possible Solution
The data being displayed is inaccurate or not what you expect.	Power meter is grounded incorrectly.	Verify that the power meter is grounded as described in “Grounding the Power Meter” in the installation manual.
	Incorrect setup values.	Check that the correct values have been entered for power meter setup parameters (CT and PT ratings, System Type, Nominal Frequency, and so on). See “Set Up the Power Meter” on page 16 for setup instructions.
	Incorrect voltage inputs.	Check power meter voltage input terminals L (8, 9, 10, 11) to verify that adequate voltage is present.
	Power meter is wired improperly.	Check that all CTs and PTs are connected correctly (proper polarity is observed) and that they are energized. Check shorting terminals. See Chapter 4 — Wiring in the installation manual. Initiate a wiring check using SMS.
Cannot communicate with power meter from a remote personal computer.	Power meter address is incorrect.	Check to see that the power meter is correctly addressed. See “Power Meter With Integrated Display Communications Setup” on page 17 for instructions.
	Power meter baud rate is incorrect.	Verify that the baud rate of the power meter matches the baud rate of all other devices on its communications link. See “Power Meter With Integrated Display Communications Setup” on page 17 for instructions.
	Communications lines are improperly connected.	Verify the power meter communications connections. Refer to Chapter 5 — Communications in the installation manual for instructions.
	Communications lines are improperly terminated.	Check to see that a multipoint communications terminator is properly installed. See “Terminating the Communications Link” on page 28 in the installation manual for instructions.
	Incorrect route statement to power meter.	Check the route statement. Refer to the SMS online help for instructions on defining route statements.

APPENDIX A—POWER METER REGISTER LIST

About Registers

The four tables in this appendix contain an abbreviated listing of power meter registers. For registers defined in bits, the rightmost bit is referred to as bit 00. Figure A–1 shows how bits are organized in a register.

Figure A–1: Bits in a register

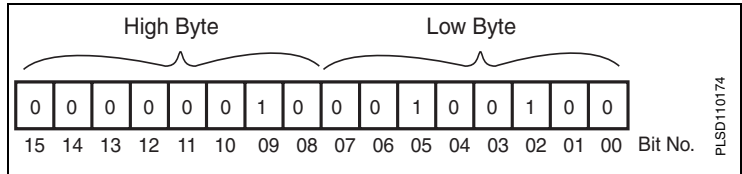

The power meter registers can be used with MODBUS or JBUS protocols. Although the MODBUS protocol uses a zero-based register addressing convention and JBUS protocol uses a one-based register addressing convention, the power meter automatically compensates for the MODBUS offset of one. Regard all registers as holding registers where a 30,000 or 40,000 offset can be used. For example, Current Phase A will reside in register 31,100 or 41,100 instead of 1,100 as listed in Table A–3 on page 108.

Floating-point Registers

Floating-point registers are also available. See Table A–7 on page 164 for an abbreviated list of floating-point registers. To enable floating-point registers, see “Enabling Floating-point Registers” on page 194.

How Power Factor is Stored in the Register

Each power factor value occupies one register. Power factor values are stored using signed magnitude notation (see Figure A–2 below). Bit number 15, the sign bit, indicates leading/lagging. A positive value (bit 15=0) always indicates leading. A negative value (bit 15=1) always indicates lagging. Bits 0–9 store a value in the range 0–1,000 decimal. For example the power meter would return a leading power factor of 0.5 as 500. Divide by 1,000 to get a power factor in the range 0 to 1.000.

Figure A–2: Power factor

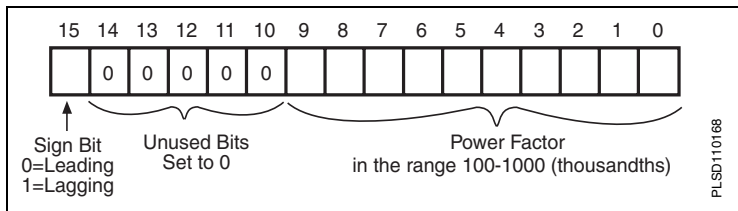

When the power factor is lagging, the power meter returns a high negative value—for example, -31,794. This happens because bit 15=1 (for example, the binary equivalent of -31,794 is 1000011110011110). To get a value in the range 0 to 1,000, you need to mask bit 15. You do this by adding 32,768 to the value. An example will help clarify.

Assume that you read a power factor value of -31,794. Convert this to a power factor in the range 0 to 1.000, as follows:

$$-31,794 + 32,768 = 974$$

$$974/1,000 = .974 \text{ lagging power factor}$$

How Date and Time are Stored in Registers

The date and time are stored in a three-register compressed format. Each of the three registers, such as registers 1810 to 1812, contain a high and low byte value to represent the date and time in hexadecimal. Table A–1 lists the register and the portion of the date or time it represents.

Table A–1: Date and Time Format

Register	Hi Byte	Lo Byte
Register 0	Month (1-12)	Day (1-31)
Register 1	Year (0-199)	Hour (0-23)
Register 2	Minute (0-59)	Second (0-59)

For example, if the date was 01/25/00 at 11:06:59, the Hex value would be 0119, 640B, 063B. Breaking it down into bytes we have the following:

NOTE: Date format is a 3 (6-byte) register compressed format. (Year 2001 is represented as 101 in the year byte.)

Table A–2: Date and Time Byte Example

Hexadecimal Value	Hi Byte	Lo Byte
0119	01 = month	19 = day
640B	64 = year	0B = hour
063B	06 = minute	3B = seconds

Register List

Table A-3: Abbreviated Register List

Reg	Name	Scale	Units	Range	Notes
1s Metering					
1s Metering — Current					
1100	Current, Phase A	A	Amps/Scale	0 – 32,767	RMS
1101	Current, Phase B	A	Amps/Scale	0 – 32,767	RMS
1102	Current, Phase C	A	Amps/Scale	0 – 32,767	RMS
1103	Current, Neutral	B	Amps/Scale	0 – 32,767 (-32,768 if N/A)	RMS (4-wire system only)
1105	Current, 3-Phase Average	A	Amps/Scale	0 – 32,767	Calculated mean of Phases A, B & C
1107	Current, Unbalance, Phase A	—	0.10%	0 – 1,000	
1108	Current, Unbalance, Phase B	—	0.10%	0 – 1,000	
1109	Current, Unbalance, Phase C	—	0.10%	0 – 1,000	
1110	Current, Unbalance, Max	—	0.10%	0 – 1,000	Percent Unbalance, Worst
1s Metering — Voltage					
1120	Voltage, A-B	D	Volts/Scale	0 – 32,767	RMS Voltage measured between A & B
1121	Voltage, B-C	D	Volts/Scale	0 – 32,767	RMS Voltage measured between B & C
1122	Voltage, C-A	D	Volts/Scale	0 – 32,767	RMS Voltage measured between C & A
1123	Voltage, L-L Average	D	Volts/Scale	0 – 32,767	RMS 3 Phase Average L-L Voltage
1124	Voltage, A-N	D	Volts/Scale	0 – 32,767 (-32,768 if N/A)	RMS Voltage measured between A & N 4-wire system, system 10, and system 12
1125	Voltage, B-N	D	Volts/Scale	0 – 32,767 (-32,768 if N/A)	RMS Voltage measured between B & N 4-wire system and system 12
1126	Voltage, C-N	D	Volts/Scale	0 – 32,767 (-32,768 if N/A)	RMS Voltage measured between C & N 4-wire system only
1127	Voltage, N-R	E	Volts/Scale	0 – 32,767 (-32,768 if N/A)	RMS Voltage measured between N & meter reference 4-wire system with 4 element metering only
1128	Voltage, L-N Average	D	Volts/Scale	0 – 32,767	RMS 3-Phase Average L-N Voltage (2-phase average for system 12)
1129	Voltage, Unbalance, A-B	—	0.10%	0 – 1,000	Percent Voltage Unbalance, Phase A-B
1130	Voltage, Unbalance, B-C	—	0.10%	0 – 1,000	Percent Voltage Unbalance, Phase B-C
1131	Voltage, Unbalance, C-A	—	0.10%	0 – 1,000	Percent Voltage Unbalance, Phase C-A
1132	Voltage, Unbalance, Max L-L	—	0.10%	0 – 1,000	Percent Voltage Unbalance, Worst L-L

Table A-3: Abbreviated Register List

Reg	Name	Scale	Units	Range	Notes
1133	Voltage, Unbalance, A-N	—	0.10%	0 – 1,000 (-32,768 if N/A)	Percent Voltage Unbalance, Phase A-N 4-wire system only
1134	Voltage, Unbalance, B-N	—	0.10%	0 – 1,000 (-32,768 if N/A)	Percent Voltage Unbalance, Phase B-N 4-wire system only
1135	Voltage, Unbalance, C-N	—	0.10%	0 – 1,000 (-32,768 if N/A)	Percent Voltage Unbalance, Phase C-N 4-wire system only
1136	Voltage, Unbalance, Max L-N	—	0.10%	0 – 1,000 (-32,768 if N/A)	Percent Voltage Unbalance, Worst L-N 4-wire system only
1s Metering — Power					
1140	Real Power, Phase A	F	kW/Scale	-32,767 – 32,767 (-32,768 if N/A)	Real Power (PA) 4-wire system only
1141	Real Power, Phase B	F	kW/Scale	-32,767 – 32,767 (-32,768 if N/A)	Real Power (PB) 4-wire system only
1142	Real Power, Phase C	F	kW/Scale	-32,767 – 32,767 (-32,768 if N/A)	Real Power (PC) 4-wire system only
1143	Real Power, Total	F	kW/Scale	-32,767 – 32,767	4-wire system = PA+PB+PC 3-wire system = 3-Phase real power
1144	Reactive Power, Phase A	F	kVAr/Scale	-32,767 – 32,767 (-32,768 if N/A)	Reactive Power (QA) 4-wire system only
1145	Reactive Power, Phase B	F	kVAr/Scale	-32,767 – 32,767 (-32,768 if N/A)	Reactive Power (QB) 4-wire system only
1146	Reactive Power, Phase C	F	kVAr/Scale	-32,767 – 32,767 (-32,768 if N/A)	Reactive Power (QC) 4-wire system only
1147	Reactive Power, Total	F	kVAr/Scale	-32,767 – 32,767	4-wire system = QA+QB+QC 3-wire system = 3-Phase reactive power
1148	Apparent Power, Phase A	F	kVA/Scale	-32,767 – 32,767 (-32,768 if N/A)	Apparent Power (SA) 4-wire system only
1149	Apparent Power, Phase B	F	kVA/Scale	-32,767 – 32,767 (-32,768 if N/A)	Apparent Power (SB) 4-wire system only
1150	Apparent Power, Phase C	F	kVA/Scale	-32,767 – 32,767 (-32,768 if N/A)	Apparent Power (SC) 4-wire system only
1151	Apparent Power, Total	F	kVA/Scale	-32,767 – 32,767	4-wire system = SA+SB+SC 3-wire system = 3-Phase apparent power
1s Metering — Power Factor					
1160	True Power Factor, Phase A	—	0.001	-0.002 to 1.000 to +0.002 (-32,768 if N/A)	Derived using the complete harmonic content of real and apparent power. 4-wire system only
1161	True Power Factor, Phase B	—	0.001	-0.002 to 1.000 to +0.002 (-32,768 if N/A)	Derived using the complete harmonic content of real and apparent power. 4-wire system only

Table A-3: Abbreviated Register List

Reg	Name	Scale	Units	Range	Notes
1162	True Power Factor, Phase C	—	0.001	-0.002 to 1.000 to +0.002 (-32,768 if N/A)	Derived using the complete harmonic content of real and apparent power. 4-wire system only
1163	True Power Factor, Total	—	0.001	-0.002 to 1.000 to +0.002 (-32,768 if N/A)	Derived using the complete harmonic content of real and apparent power
1164	Alternate True Power Factor, Phase A	—	0.001	0 – 2,000 (-32,768 if N/A)	Derived using the complete harmonic content of real and apparent power (4-wire system only). The reported value is mapped from 0-2000, with 1000 representing unity, values below 1000 representing lagging, and values above 1000 representing leading.
1165	Alternate True Power Factor, Phase B	—	0.001	0 – 2,000 (-32,768 if N/A)	Derived using the complete harmonic content of real and apparent power (4-wire system only). The reported value is mapped from 0-2000, with 1000 representing unity, values below 1000 representing lagging, and values above 1000 representing leading.
1166	Alternate True Power Factor, Phase C	—	0.001	0 – 2,000 (-32,768 if N/A)	Derived using the complete harmonic content of real and apparent power (4-wire system only). The reported value is mapped from 0-2000, with 1000 representing unity, values below 1000 representing lagging, and values above 1000 representing leading.
1167	Alternate True Power Factor, Total	—	0.001	0 – 2,000	Derived using the complete harmonic content of real and apparent power. The reported value is mapped from 0-2000, with 1000 representing unity, values below 1000 representing lagging, and values above 1000 representing leading.
1168	Displacement Power Factor, Phase A	—	0.001	-0.002 to 1.000 to +0.002 (-32,768 if N/A)	Derived using only fundamental frequency of the real and apparent power. 4-wire system only
1169	Displacement Power Factor, Phase B	—	0.001	-0.002 to 1.000 to +0.002 (-32,768 if N/A)	Derived using only fundamental frequency of the real and apparent power. 4-wire system only
1170	Displacement Power Factor, Phase C	—	0.001	-0.002 to 1.000 to +0.002 (-32,768 if N/A)	Derived using only fundamental frequency of the real and apparent power. 4-wire system only
1171	Displacement Power Factor, Total	—	0.001	-0.002 to 1.000 to +0.002 (-32,768 if N/A)	Derived using only fundamental frequency of the real and apparent power
1172	Alternate Displacement Power Factor, Phase A	—	0.001	0 – 2,000 (-32,768 if N/A)	Derived using only fundamental frequency of the real and apparent power (4-wire system only). The reported value is mapped from 0-2000, with 1000 representing unity, values below 1000 representing lagging, and values above 1000 representing leading.

Table A–3: Abbreviated Register List

Reg	Name	Scale	Units	Range	Notes
1173	Alternate Displacement Power Factor, Phase B	—	0.001	0 – 2,000 (-32,768 if N/A)	Derived using only fundamental frequency of the real and apparent power (4-wire system only). The reported value is mapped from 0-2000, with 1000 representing unity, values below 1000 representing lagging, and values above 1000 representing leading.
1174	Alternate Displacement Power Factor, Phase C	—	0.001	0 – 2,000 (-32,768 if N/A)	Derived using only fundamental frequency of the real and apparent power (4-wire system only). The reported value is mapped from 0-2000, with 1000 representing unity, values below 1000 representing lagging, and values above 1000 representing leading.
1175	Alternate Displacement Power Factor, Total	—	0.001	0 – 2,000	Derived using only fundamental frequency of the real and apparent power. The reported value is mapped from 0-2000, with 1000 representing unity, values below 1000 representing lagging, and values above 1000 representing leading.
1s Metering — Frequency					
1180	Frequency	—	0.01Hz 0.10Hz	(50/60Hz) 2,300 – 6,700 (400Hz) 3,500 – 4,500 (-32,768 if N/A)	Frequency of circuits being monitored. If the frequency is out of range, the register is -32,768.
Power Quality					
THD					
1200	THD/thd Current, Phase A	—	0.10%	0 – 32,767	Total Harmonic Distortion, Phase A Current See register 3227 for THD/ thd definition
1201	THD/thd Current, Phase B	—	0.10%	0 – 32,767	Total Harmonic Distortion, Phase B Current See register 3227 for THD/ thd definition
1202	THD/thd Current, Phase C	—	0.10%	0 – 32,767	Total Harmonic Distortion, Phase C Current See register 3227 for THD/ thd definition
1203	THD/thd Current, Phase N	—	0.10%	0 – 32,767 (-32,768 if N/A)	Total Harmonic Distortion, Phase N Current (4-wire system only) See register 3227 for THD/ thd definition
1207	THD/thd Voltage, Phase A-N	—	0.10%	0 – 32,767 (-32,768 if N/A)	Total Harmonic Distortion Phase A-N (4-wire system only) See register 3227 for THD/ thd definition
1208	THD/thd Voltage, Phase B-N	—	0.10%	0 – 32,767 (-32,768 if N/A)	Total Harmonic Distortion Phase B-N (4-wire system only) See register 3227 for THD/ thd definition
1209	THD/thd Voltage, Phase C-N	—	0.10%	0 – 32,767 (-32,768 if N/A)	Total Harmonic Distortion Phase C-N (4-wire system only) See register 3227 for THD/ thd definition

Table A-3: Abbreviated Register List

Reg	Name	Scale	Units	Range	Notes
1211	THD/thd Voltage, Phase A-B	—	0.10%	0 – 32,767	Total Harmonic Distortion Phase A-B See register 3227 for THD/ thd definition
1212	THD/thd Voltage, Phase B-C	—	0.10%	0 – 32,767	Total Harmonic Distortion Phase B-C See register 3227 for THD/ thd definition
1213	THD/thd Voltage, Phase C-A	—	0.10%	0 – 32,767	Total Harmonic Distortion Phase C-A See register 3227 for THD/ thd definition
Fundamental Magnitudes and Angles					
Current					
1230	Current Fundamental RMS Magnitude, Phase A	A	Amps/Scale	0 – 32,767	
1231	Current Fundamental Coincident Angle, Phase A	—	0.1°	0 – 3,599	Referenced to A-N/A-B Voltage Angle
1232	Current Fundamental RMS Magnitude, Phase B	A	Amps/Scale	0 – 32,767	
1233	Current Fundamental Coincident Angle, Phase B	—	0.1°	0 – 3,599	Referenced to A-N/A-B Voltage Angle
1234	Current Fundamental RMS Magnitude, Phase C	A	Amps/Scale	0 – 32,767	
1235	Current Fundamental Coincident Angle, Phase C	—	0.1°	0 – 3,599	Referenced to A-N/A-B Voltage Angle
1236	Current Fundamental RMS Magnitude, Neutral	B	Amps/Scale	0 – 32,767 (-32,768 if N/A)	4-wire system only
1237	Current Fundamental Coincident Angle, Neutral	—	0.1°	0 – 3,599 (-32,768 if N/A)	Referenced to A-N 4-wire system only
Voltage					
1244	Voltage Fundamental RMS Magnitude, A-N/A-B	D	Volts/Scale	0 – 32,767	Voltage A-N (4-wire system) Voltage A-B (3-wire system)
1245	Voltage Fundamental Coincident Angle, A-N/A-B	—	0.1°	0 – 3,599	Referenced to A-N (4-wire) or A-B (3-wire)
1246	Voltage Fundamental RMS Magnitude, B-N/B-C	D	Volts/Scale	0 – 32,767	Voltage B-N (4-wire system) Voltage B-C (3-wire system)
1247	Voltage Fundamental Coincident Angle, B-N/B-C	—	0.1°	0 – 3,599	Referenced to A-N (4-wire) or A-B (3-wire)
1248	Voltage Fundamental RMS Magnitude, C-N/C-A	D	Volts/Scale	0 – 32,767	Voltage C-N (4-wire system) Voltage C-A (3-wire system)

Table A-3: Abbreviated Register List

Reg	Name	Scale	Units	Range	Notes
1249	Voltage Fundamental Coincident Angle, C-N/C-A	—	0.1°	0 – 3,599	Referenced to A-N (4-wire) or A-B (3-wire)
Sequence Components					
1284	Current, Positive Sequence, Magnitude	A	Amps/Scale	0 – 32,767	
1285	Current, Positive Sequence, Angle	—	0.1	0 – 3,599	
1286	Current, Negative Sequence, Magnitude	A	Amps/Scale	0 – 32,767	
1287	Current, Negative Sequence, Angle	—	0.1	0 – 3,599	
1288	Current, Zero Sequence, Magnitude	A	Amps/Scale	0 – 32,767	
1289	Current, Zero Sequence, Angle	—	0.1	0 – 3,599	
1290	Voltage, Positive Sequence, Magnitude	D	Volts/Scale	0 – 32,767	
1291	Voltage, Positive Sequence, Angle	—	0.1	0 – 3,599	
1292	Voltage, Negative Sequence, Magnitude	D	Volts/Scale	0 – 32,767	
1293	Voltage, Negative Sequence, Angle	—	0.1	0 – 3,599	
1294	Voltage, Zero Sequence, Magnitude	D	Volts/Scale	0 – 32,767	
1295	Voltage, Zero Sequence, Angle	—	0.1	0 – 3,599	
1296	Current, Sequence, Unbalance	—	0.10%	0 – 10,000	
1297	Voltage, Sequence, Unbalance	—	0.10%	0 – 10,000	
1298	Current, Sequence Unbalance Factor	—	0.10%	0 – 10,000	Negative Sequence / Positive Sequence
1299	Voltage, Sequence Unbalance Factor	—	0.10%	0 – 10,000	Negative Sequence / Positive Sequence

Table A-3: Abbreviated Register List

Reg	Name	Scale	Units	Range	Notes
Minimum/Maximum					
Present Month Min/Max Group 1					
1300	Min/Max Voltage L-L	—	—	—	See "Minimum/Maximum Template" on page 115
1310	Min/Max Voltage L-N	—	—	—	See "Minimum/Maximum Template" on page 115
1320	Min/Max Current	—	—	—	See "Minimum/Maximum Template" on page 115
1330	Min/Max Voltage L-L, Unbalance	—	—	—	See "Minimum/Maximum Template" on page 115
1340	Min/Max Voltage L-N Unbalance	—	—	—	See "Minimum/Maximum Template" on page 115
1350	Min/Max True Power Factor Total	—	—	—	See "Minimum/Maximum Template" on page 115
1360	Min/Max Displacement Power Factor Total	—	—	—	See "Minimum/Maximum Template" on page 115
1370	Min/Max Real Power Total	—	—	—	See "Minimum/Maximum Template" on page 115
1380	Min/Max Reactive Power Total	—	—	—	See "Minimum/Maximum Template" on page 115
1390	Min/Max Apparent Power Total	—	—	—	See "Minimum/Maximum Template" on page 115
1400	Min/Max THD/thd Voltage L-L	—	—	—	See "Minimum/Maximum Template" on page 115
1410	Min/Max THD/thd Voltage L-N	—	—	—	See "Minimum/Maximum Template" on page 115
1420	Min/Max THD/thd Current	—	—	—	See "Minimum/Maximum Template" on page 115
1430	Min/Max Frequency	—	—	—	See "Minimum/Maximum Template" on page 115
1440	Date/Time of last Present Month Min/Max Update	—	See Table A-1 on page 107	See Table A-1 on page 107	Date/Time of last Present Month Min/Max Update
Previous Month Min/Max Group 1					
1450	Min/Max Voltage L-L	—	—	—	See "Minimum/Maximum Template" on page 115
1460	Min/Max Voltage L-N	—	—	—	See "Minimum/Maximum Template" on page 115
1470	Min/Max Current	—	—	—	See "Minimum/Maximum Template" on page 115
1480	Min/Max Voltage L-L, Unbalance	—	—	—	See "Minimum/Maximum Template" on page 115
1490	Min/Max Voltage L-N Unbalance	—	—	—	See "Minimum/Maximum Template" on page 115

Table A–3: Abbreviated Register List

Reg	Name	Scale	Units	Range	Notes
1500	Min/Max True Power Factor Total	—	—	—	See "Minimum/Maximum Template" on page 115
1510	Min/Max Displacement Power Factor Total	—	—	—	See "Minimum/Maximum Template" on page 115
1520	Min/Max Real Power Total	—	—	—	See "Minimum/Maximum Template" on page 115
1530	Min/Max Reactive Power Total	—	—	—	See "Minimum/Maximum Template" on page 115
1540	Min/Max Apparent Power Total	—	—	—	See "Minimum/Maximum Template" on page 115
1550	Min/Max THD/thd Voltage L-L	—	—	—	See "Minimum/Maximum Template" on page 115
1560	Min/Max THD/thd Voltage L-N	—	—	—	See "Minimum/Maximum Template" on page 115
1570	Min/Max THD/thd Current	—	—	—	See "Minimum/Maximum Template" on page 115
1580	Min/Max Frequency	—	—	—	See "Minimum/Maximum Template" on page 115
1590	Min/Max End Time	—	See "Minimum/Maximum Template" on page 115	See "Minimum/Maximum Template" on page 115	
Present Month Min/Max Group 2					
1600	Min/Max Voltage N-ground	—	—	—	See "Minimum/Maximum Template" on page 115
1610	Min/Max Current, Neutral	—	—	—	See "Minimum/Maximum Template" on page 115
Previous Month Min/Max Group 2					
1650	Min/Max Voltage N-ground	—	—	—	See "Minimum/Maximum Template" on page 115
1660	Min/Max Current, Neutral	—	—	—	See "Minimum/Maximum Template" on page 115
Minimum/Maximum Template					
Base	Date/Time of Min	—	Table A–1 on page 107	Table A–1 on page 107	Date/Time when Min was recorded
Base+3	Min Value			0 – 32,767	Min value metered for all phases
Base+4	Phase of recorded Min*	—		1 to 3	Phase of Min recorded
Base+5	Date/Time of Max	—	Table A–1 on page 107	Table A–1 on page 107	Date/Time when Max was recorded
Base+8	Max Value			0 – 32,767	Max value metered for all phases
Base+9	Phase of recorded Max*	—		1 to 3	Phase of Max recorded

* Only applicable for multi-phase quantities

Table A-3: Abbreviated Register List

Reg	Name	Scale	Units	Range	Notes
Energy					
1700	Energy, Real In	—	WH	(1)	3-Phase total real energy into the load
1704	Energy, Reactive In	—	VArH	(1)	3-Phase total reactive energy into the load
1708	Energy, Real Out	—	WH	(1)	3-Phase total real energy out of the load
1712	Energy, Reactive Out	—	VArH	(1)	3-Phase total reactive energy out of the load
1716	Energy, Real Total (signed/absolute)	—	WH	(2)	Total Real Energy In, Out or In + Out
1720	Energy, Reactive Total (signed/absolute)	—	VArH	(2)	Total Reactive Energy In, Out or In + Out
1724	Energy, Apparent	—	VAH	(1)	3-Phase total apparent energy
1728	Energy, Conditional Real In	—	WH	(1)	3-Phase total accumulated conditional real energy into the load
1732	Energy, Conditional Reactive In	—	VArH	(1)	3-Phase total accumulated conditional reactive energy into the load
1736	Energy, Conditional Real Out	—	WH	(1)	3-Phase total accumulated conditional real energy out of the load
1740	Energy, Conditional Reactive Out	—	VArH	(1)	3-Phase total accumulated conditional reactive energy out of the load
1744	Energy, Conditional Apparent	—	VAH	(1)	3-Phase total accumulated conditional apparent energy
1748	Energy, Incremental Real In, Last Complete Interval	—	WH	(3)	3-Phase total accumulated incremental real energy into the load
1751	Energy, Incremental Reactive In, Last Complete Interval	—	VArH	(3)	3-Phase total accumulated incremental reactive energy into the load
1754	Energy, Incremental Real Out, Last Complete Interval	—	WH	(3)	3-Phase total accumulated incremental real energy out of the load
1757	Energy, Incremental Reactive Out, Last Complete Interval	—	VArH	(3)	3-Phase total accumulated incremental reactive energy out of the load
1760	Energy, Incremental Apparent, Last Complete Interval	—	VAH	(3)	3-Phase total accumulated incremental apparent energy
1763	Last Complete Interval Date/Time	—	Table A-1 on page 107	Table A-1 on page 107	Date/Time of last completed incremental energy interval
1767	Energy, Incremental Real In, Present Interval	—	WH	(3)	3-Phase total accumulated incremental real energy into the load
1770	Energy, Incremental Reactive In, Present Interval	—	VArH	(3)	3-Phase total accumulated incremental reactive energy into the load
1773	Energy, Incremental Real Out, Present Interval	—	WH	(3)	3-Phase total accumulated incremental real energy out of the load

Table A-3: Abbreviated Register List

Reg	Name	Scale	Units	Range	Notes
1776	Energy, Incremental Reactive Out, Present Interval	—	VArH	(3)	3-Phase total accumulated incremental reactive energy out of the load
1779	Energy, Incremental Apparent, Present Interval	—	VAH	(3)	3-Phase total accumulated incremental apparent energy
1782	Energy, Reactive, Quadrant 1	—	VArH	(3)	3-Phase total accumulated incremental reactive energy – quadrant 1
1785	Energy, Reactive, Quadrant 2	—	VArH	(3)	3-Phase total accumulated incremental reactive energy – quadrant 2
1788	Energy, Reactive, Quadrant 3	—	VArH	(3)	3-Phase total accumulated incremental reactive energy – quadrant 3
1791	Energy, Reactive, Quadrant 4	—	VArH	(3)	3-Phase total accumulated incremental reactive energy – quadrant 4
1794	Conditional Energy Control Status	—	—	0 – 1	0 = Off (default) 1 = On
(1) 0 – 9,999,999,999,999,999					
(2) -9,999,999,999,999,999 – 9,999,999,999,999,999					
(3) 0 – 999,999,999,999					
Demand					
Demand — Current Demand System Configuration and Data					
1800	Demand Calculation Mode Current	—	—	0 – 1024	0 = Thermal Demand (default) 1 = Timed Interval Sliding Block 2 = Timed Interval Block 4 = Timed Interval Rolling Block 8 = Input Synchronized Block 16 = Input Synchronized Rolling Block 32 = Command Synchronized Block 64 = Command Synchronized Rolling Block 128 = Clock Synchronized Block 256 = Clock Synchronized Rolling Block 512 = Slave to Power Demand Interval 1024 = Slave to Incremental Energy Interval
1801	Demand Interval Current	—	Minutes	1 – 60	Default = 15
1802	Demand Subinterval Current	—	Minutes	1 – 60	Default = 1
1803	Demand Sensitivity Current	—	1%	1 – 99	Adjusts the sensitivity of the thermal demand calculation. Default = 90
1805	Short Demand Interval Current	—	Seconds	0 – 60	Sets the interval for a running average demand calculation of short duration. Default = 15
1806	Time Elapsed in Interval Current	—	Seconds	0 – 3,600	Time elapsed in the present demand interval.

Table A-3: Abbreviated Register List

Reg	Name	Scale	Units	Range	Notes
1807	Time Elapsed in Subinterval Current	—	Seconds	0 – 3,600	Time elapsed in the present demand subinterval.
1808	Interval Count Current	—	1.0	0 – 32,767	Count of demand intervals. Rolls over at 32,767.
1809	Subinterval Count Current	—	1.0	0 – 60	Count of demand subintervals. Rolls over at interval.
1810	Min/Max Reset DateTime Current	—	Table A-1 on page 107	Table A-1 on page 107	Date/Time of last reset of Current Demand Min/Max demands
1814	Min/Max Reset Count Current	—	1.0	0 – 32,767	Count of Min/Max demand resets. Rolls over at 32,767.
1815	Demand System Status Current	—	—	0x0000 – 0x000F	Bit 00 = end of demand subinterval Bit 01 = end of demand interval Bit 02 = start of first complete interval Bit 03 = end of first complete interval
Demand — Power Demand System Configuration and Data					
1840	Demand Calculation Mode Power	—	—	0 – 1024	0 = Thermal Demand(it) 1 = Timed Interval Sliding Block 2 = Timed Interval Block 4 = Timed Interval Rolling Block 8 = Input Synchronized Block 16 = Input Synchronized Rolling Block 32 = Command Synchronized Block 64 = Command Synchronized Rolling Block 128 = Clock Synchronized Block 256 = Clock Synchronized Rolling Block 1024 = Slave to Incremental Energy Interval
1841	Demand Interval Power	—	Minutes	1 – 60	Default = 15
1842	Demand Subinterval Power	—	Minutes	1 – 60	Default = 1
1843	Demand Sensitivity Power	—	1%	1 – 99	Adjusts the sensitivity of the thermal demand calculation. Default = 90
1844	Predicted Demand Sensitivity Power	—	1.0	1 – 10	Adjusts sensitivity of predicted demand calculation to recent changes in power consumption. Default = 5.
1845	Short Demand Interval Power	—	Seconds	0 – 60	Sets the interval for a running average demand calculation of short duration. Default = 15
1846	Time Elapsed in Interval Power	—	Seconds	0 – 3,600	Time elapsed in the present demand interval.

Table A-3: Abbreviated Register List

Reg	Name	Scale	Units	Range	Notes
1847	Time Elapsed in Subinterval Power	—	Seconds	0 – 3,600	Time elapsed in the present demand subinterval.
1848	Interval Count Power	—	1.0	0 – 32,767	Count of demand intervals. Rolls over at 32,767.
1849	Subinterval Count Power	—	1.0	0 – 60	Count of demand subintervals. Rolls over at interval.
1850	Min/Max Reset DateTime Power	—	Table A-1 on page 107	Table A-1 on page 107	Date/Time of last reset of Power Demand Min/Max demands
1854	Min/Max Reset Count Power	—	1.0	0 – 32,767	Count of Min/Max demand resets. Rolls over at 32,767.
1855	Demand System Status Power	—	—	0x0000 – 0x000F	Bit 00 = end of demand subinterval Bit 01 = end of demand interval Bit 02 = start of first complete interval Bit 03 = end of first complete interval
Demand — Input Metering Demand System Configuration and Data					
1860	Demand Calculation Mode Input Pulse Metering	—	—	0 – 1024	0 = Thermal Demand 1 = Timed Interval Sliding Block 2 = Timed Interval Block (default) 4 = Timed Interval Rolling Block 8 = Input Synchronized Block 16 = Input Synchronized Rolling Block 32 = Command Synchronized Block 64 = Command Synchronized Rolling Block 128 = Clock Synchronized Block 256 = Clock Synchronized Rolling Block 512 = Slave to Power Demand Interval 1024 = Slave to Incremental Energy Interval
1861	Demand Interval Input Pulse Metering	—	Minutes	1 – 60	Default = 15
1862	Demand Subinterval Input Pulse Metering	—	Minutes	1 – 60	Default = 1
1863	Demand Sensitivity Input Pulse Metering	—	%	1 – 99	Adjusts the sensitivity of the thermal demand calculation. Default = 90
1865	Short Demand Interval Input Pulse Metering	—	Seconds	0 – 60	Sets the interval for a running average demand calculation of short duration. Default = 15
1866	Time Elapsed in Interval Input Pulse Metering	—	Seconds	0 – 3,600	
1867	Time Elapsed in Subinterval Input Pulse Metering	—	Seconds	0 – 3,600	

Table A-3: Abbreviated Register List

Reg	Name	Scale	Units	Range	Notes
1868	Interval Count Input Pulse Metering	—	1.0	0 – 32,767	Rolls over at 32,767.
1869	Subinterval Count Input Pulse Metering	—	1.0	0 – 60	Rolls over at interval.
1870	Min/Max Reset Date/Time Input Pulse Metering	—	Table A-1 on page 107	Table A-1 on page 107	
1874	Min/Max Reset Count Input Pulse Metering	—	1.0	0 – 32,767	Rolls over at 32,767.
1875	Demand System Status Input Pulse Metering	—	—	0x0000 – 0x000F	Bit 00 = end of demand subinterval Bit 01 = end of demand interval Bit 02 = start of first complete interval Bit 03 = end of first complete interval
Demand — Generic Demand System Configuration and Data					
1880	Demand Calculation Mode Generic Group 1	—	—	0 – 1024	0 = Thermal Demand (default) 1 = Timed Interval Sliding Block 2 = Timed Interval Block 4 = Timed Interval Rolling Block 8 = Input Synchronized Block 16 = Input Synchronized Rolling Block 32 = Command Synchronized Block 64 = Command Synchronized Rolling Block 128 = Clock Synchronized Block 256 = Clock Synchronized Rolling Block 512 = Slave to Power Demand Interval 1024 = Slave to Incremental Energy Interval
1881	Demand Interval Generic	—	Minutes	1 – 60	Default = 15
1882	Demand Subinterval Generic	—	Minutes	1 – 60	Default = 1
1883	Demand Sensitivity Generic	—	1%	1 – 99	Adjusts the sensitivity of the thermal demand calculation. Default = 90
1885	Short Demand Interval Generic	—	Seconds	0 – 60	Sets the interval for a running average demand calculation of short duration. Default = 15
1886	Time Elapsed in Interval Generic	—	Seconds	0 – 3,600	Time elapsed in the present demand interval.
1887	Time Elapsed in Subinterval Generic	—	Seconds	0 – 3,600	Time elapsed in the present demand subinterval.
1888	Interval Count Generic	—	1.0	0 – 32,767	Count of demand intervals. Rolls over at 32,767.

Table A-3: Abbreviated Register List

Reg	Name	Scale	Units	Range	Notes
1889	Subinterval Count Generic	—	1.0	0 – 60	Count of demand subintervals. Rolls over at interval.
1890	Min/Max Reset DateTime Generic	—	Table A-1 on page 107	Table A-1 on page 107	Date/Time of last reset of Generic Group 1 Demand Min/Max demands
1894	Min/Max Reset Count Generic	—	1.0	0 – 32,767	Count of Min/Max demand resets. Rolls over at 32,767.
1895	Demand System Status Generic	—	—	0x0000 – 0x000F	Bit 00 = end of demand subinterval Bit 01 = end of demand interval Bit 02 = start of first complete interval Bit 03 = end of first complete interval
Demand — Miscellaneous Demand System Configuration and Data					
1920	Demand Forgiveness Duration	—	Seconds	0 – 3,600	Duration of time after a power outage, during which power demand is not calculated
1921	Demand Forgiveness Outage Definition	—	Seconds	0 – 3,600	Duration of time that metered voltage must be lost to be considered a power outage for demand forgiveness
1923	Clock Sync Time of Day	—	Minutes	0 – 1,440	Time of day, in minutes from midnight, to which the demand interval is to be synchronized. Applies to demand intervals configured as Clock Synchronized.
1924	Power Factor Average Over Last Power Demand Interval	—	0.001	-0.001 to 1000 to 0.001 (-32,768 if N/A)	
1925	Cumulative Demand Reset DateTime	—	Table A-1 on page 107	Table A-1 on page 107	Date/Time of the last reset of cumulative demand
1929	Cumulative Input Pulse Metering Reset DateTime	—	Table A-1 on page 107	Table A-1 on page 107	Date/Time of last reset of input pulse metering accumulation
1940	Last Incremental Interval, Real Demand Peak	F	kW/Scale	-32,767 – 32,767	Maximum real 3-phase power demand over the last incremental energy interval
1941	Last Incremental Interval, Real Demand Peak DateTime	—	Table A-1 on page 107	Table A-1 on page 107	Date/Time of the Real Power Demand peak during the last completed incremental energy interval
1945	Last Incremental Interval, Reactive Demand Peak	F	kVAr/Scale	-32,767 – 32,767	Maximum reactive 3-phase power demand over the last incremental energy interval
1946	Last Incremental Interval, Reactive Demand Peak DateTime	—	Table A-1 on page 107	Table A-1 on page 107	Date/Time of the Reactive Power Demand peak during the last completed incremental energy interval
1950	Last Incremental Interval, Apparent Demand Peak	F	kVA/Scale	0 – 32,767	Maximum apparent 3-phase power demand over the last incremental energy interval
1951	Last Incremental Interval, Apparent Demand Peak DateTime	—	Table A-1 on page 107	Table A-1 on page 107	Date/Time of the Apparent Power Demand peak during the last completed incremental energy interval

Table A-3: Abbreviated Register List

Reg	Name	Scale	Units	Range	Notes
Demand — Current Demand Channels					
1960	Last Demand Current, Phase A	A	Amps/Scale	0 – 32,767	Phase A current demand, last complete interval
1961	Present Demand Current, Phase A	A	Amps/Scale	0 – 32,767	Phase A current demand, present interval
1962	Running Average Demand Current, Phase A	A	Amps/Scale	0 – 32,767	Phase A current demand, running average demand calculation of short duration
1963	Peak Demand Current, Phase A	A	Amps/Scale	0 – 32,767	Phase A peak current demand
1964	Peak Demand DateTime Current, Phase A	—	Table A-1 on page 107	Table A-1 on page 107	Date/Time of Peak Current Demand, Phase A
1970	Last Demand Current, Phase B	A	Amps/Scale	0 – 32,767	Phase B current demand, last complete interval
1971	Present Demand Current, Phase B	A	Amps/Scale	0 – 32,767	Phase B current demand, present interval
1972	Running Average Demand Current, Phase B	A	Amps/Scale	0 – 32,767	Phase B current demand, running average demand calculation of short duration
1973	Peak Demand Current Phase B	A	Amps/Scale	0 – 32,767	Phase B peak current demand
1974	Peak Demand DateTime Current Phase B	—	Table A-1 on page 107	Table A-1 on page 107	Date/Time of Peak Current Demand, Phase B
1980	Last Demand Current, Phase C	A	Amps/Scale	0 – 32,767	Phase C current demand, last complete interval
1981	Present Demand Current, Phase C	A	Amps/Scale	0 – 32,767	Phase C current demand, present interval
1982	Running Average Demand Current, Phase C	A	Amps/Scale	0 – 32,767	Phase C current demand, running average demand calculation of short duration
1983	Peak Demand Current Phase C	A	Amps/Scale	0 – 32,767	Phase C peak current demand
1984	Peak Demand DateTime Current Phase C	—	Table A-1 on page 107	Table A-1 on page 107	Date/Time of Peak Current Demand, Phase C
1990	Last Demand Current, Neutral	A	Amps/Scale	0 – 32,767 (-32,768 if N/A)	Neutral current demand, last complete interval 4-wire system only
1991	Present Demand Current, Neutral	A	Amps/Scale	0 – 32,767 (-32,768 if N/A)	Neutral current demand, present interval 4-wire system only

Table A–3: Abbreviated Register List

Reg	Name	Scale	Units	Range	Notes
1992	Running Average Demand Current, Neutral	A	Amps/Scale	0 – 32,767 (-32,768 if N/A)	Neutral current demand, running average demand calculation of short duration 4-wire system only
1993	Peak Demand Current, Neutral	A	Amps/Scale	0 – 32,767 (-32,768 if N/A)	Neutral peak current demand 4-wire system only
1994	Peak Demand Date/Time Current, Neutral	—	Table A–1 on page 107	Table A–1 on page 107 (-32,768 if N/A)	Date/Time of Peak Current Demand, Neutral 4-wire system only
2000	Last Demand Current, 3-Phase Average	A	Amps/Scale	0 – 32,767	3-Phase Average current demand, last complete interval
2001	Present Demand Current, 3-Phase Average	A	Amps/Scale	0 – 32,767	3-Phase Average current demand, present interval
2002	Running Average Demand Current, 3-Phase Average	A	Amps/Scale	0 – 32,767	3-Phase Average current demand, short sliding block
2003	Peak Demand Current, 3-Phase Average	A	Amps/Scale	0 – 32,767	3-Phase Average peak current demand
2004	Peak Demand Date/Time Current, 3-Phase Average	—	Table A–1 on page 107	Table A–1 on page 107	Date/Time of Peak Current Demand, 3-Phase Average
Demand — Power Demand Channels					
2150	Last Demand Real Power, 3-Phase Total	F	kW/Scale	-32,767 – 32,767	3-Phase total present real power demand for last completed demand interval – updated every sub-interval
2151	Present Demand Real Power, 3-Phase Total	F	kW/Scale	-32,767 – 32,767	3-Phase total present real power demand for present demand interval
2152	Running Average Demand Real Power, 3-Phase Total	F	kW/Scale	-32,767 – 32,767	Updated every second
2153	Predicted Demand Real Power, 3-Phase Total	F	kW/Scale	-32,767 – 32,767	Predicted real power demand at the end of the present interval
2154	Peak Demand Real Power, 3-Phase Total	F	kW/Scale	-32,767 – 32,767	
2155	Peak Demand Date/Time Real Power, 3-Phase Total	—	Table A–1 on page 107	Table A–1 on page 107	

Table A-3: Abbreviated Register List

Reg	Name	Scale	Units	Range	Notes
2159	Cumulative Demand Real Power, 3-Phase Total	F	kW/Scale	-2147483648 – 2147483647	
2161	Power Factor, Average @ Peak Demand, Real Power	—	0.001	1,000 -100 to 100 (-32,768 if N/A)	Average True Power Factor at the time of the Peak Real Demand
2162	Power Demand, Reactive @ Peak Demand, Real Power	F	kVAr/Scale	-32,767 – 32,767	Reactive Power Demand at the time of the Peak Real Demand
2163	Power Demand, Apparent @ Peak Demand, Real Power	F	kVA/Scale	0 – 32,767	Apparent Power Demand at the time of the Peak Real Demand
2165	Last Demand Reactive Power, 3- Phase Total	F	kVAr /Scale	-32,767 – 32,767	3-Phase total present reactive power demand for last completed demand interval – updated every sub-interval
2166	Present Demand Reactive Power, 3- Phase Total	F	kVAr /Scale	-32,767 – 32,767	3-Phase total present real power demand for present demand interval
2167	Running Average Demand Reactive Power, 3- Phase Total	F	kVAr /Scale	-32,767 – 32,767	3-Phase total present reactive power demand, running average demand calculation of short duration – updated every second
2168	Predicted Demand Reactive Power, 3- Phase Total	F	kVAr /Scale	-32,767 – 32,767	Predicted reactive power demand at the end of the present interval
2169	Peak Demand Reactive Power, 3- Phase Total	F	kVAr /Scale	-32,767 – 32,767	
2170	Peak Demand DateTime Reactive Power, 3- Phase Total	—	Table A-1 on page 107	Table A-1 on page 107	
2174	Cumulative Demand Reactive Power, 3- Phase Total	F	kVAr /Scale	-2147483648 – 2147483647	
2176	Power Factor, Average @ Peak Demand, Reactive Power	—	0.001	1,000 -100 to 100 (-32,768 if N/A)	Average True Power Factor at the time of the Peak Reactive Demand
2177	Power Demand, Real @ Peak Demand, Reactive Power	F	kW/Scale	-32,767 – 32,767	Real Power Demand at the time of the Peak Reactive Demand
2178	Power Demand, Apparent @ Peak Demand, Reactive Power	F	kVA/Scale	0 – 32,767	Apparent Power Demand at the time of the Peak Reactive Demand

Table A–3: Abbreviated Register List

Reg	Name	Scale	Units	Range	Notes
2180	Last Demand Apparent Power 3- Phase Total	F	kVA /Scale	-32,767 – 32,767	3-Phase total present apparent power demand for last completed demand interval – updated every sub-interval
2181	Present Demand Apparent Power, 3- Phase Total	F	kVA /Scale	-32,767 – 32,767	3-Phase total present apparent power demand for present demand interval
2182	Running Average Demand Apparent Power, 3- Phase Total	F	kVA /Scale	-32,767 – 32,767	3-Phase total present apparent power demand, running average demand calculation of short duration – updated every second
2183	Predicted Demand Apparent Power, 3- Phase Total	F	kVA /Scale	-32,767 – 32,767	Predicted apparent power demand at the end of the present interval
2184	Peak Demand Apparent Power, 3- Phase Total	F	kVA /Scale	-32,767 – 32,767	3-Phase total peak apparent power demand peak
2185	Peak Demand Date/Time Apparent Power, 3- Phase Total	—	Table A–1 on page 107	Table A–1 on page 107	Date/Time of 3-Phase peak apparent power demand
2189	Cumulative Demand Apparent Power, 3- Phase Total	F	kVA /Scale	-2,147,483,648– 2,147,483,647	Cumulative Demand, Apparent Power
2191	Power Factor, Average @ Peak Demand, Apparent Power	—	0.001	1,000 -100 to 100 (-32,768 if N/A)	Average True Power Factor at the time of the Peak Apparent Demand
2192	Power Demand, Real @ Peak Demand, Apparent Power	F	kW/Scale	-32,767 – 32,767	Real Power Demand at the time of the Peak Apparent Demand
2193	Power Demand, Reactive @ Peak Demand, Apparent Power	F	kVAr/Scale	0 – 32,767	Reactive Power Demand at the time of the Peak Apparent Demand
Demand — Input Metering Demand Channels					
2200	Consumption Units Code Input Channel #1	—	—	See Unit Codes	Units in which consumption is to be accumulated Default = 0
2201	Demand Units Code Input Channel #1	—	—	See Unit Codes	Units in which demand (rate) is to be expressed Default = 0
2202	Last Demand Input Channel #1	—	—	0 – 32,767	Last complete interval, updated every sub-interval
2203	Present Demand Input Channel #1	—	—	0 – 32,767	Present interval

Table A-3: Abbreviated Register List

Reg	Name	Scale	Units	Range	Notes
2204	Running Average Demand Input Channel #1	—	—	0 – 32,767	Running average demand calculation of short duration, updated every second
2205	Peak Demand Input Channel #1	—	—	0 – 32,767	
2206	Peak Demand Date/Time Input Channel #1	—	Table A-1 on page 107	Table A-1 on page 107	
2210	Minimum Demand Input Channel #1	—	—	0 – 32,767	
2211	Minimum Demand Date/Time Input Channel #1	—	Table A-1 on page 107	Table A-1 on page 107	
2215	Cumulative Usage Input Channel #1	—	(2)	(1)	The user must identify the units to be used in the accumulation.
2220	Input Channel #2				Same as registers 2200 – 2219 except for Channel #2
2240	Input Channel #3				Same as registers 2200 – 2219 except for Channel #3
2260	Input Channel #4				Same as registers 2200 – 2219 except for Channel #4
2280	Input Channel #5				Same as registers 2200 – 2219 except for Channel #5
Demand — Generic Group 1 Demand Channels					
2400	Input Register Generic Channel #1	—	—	—	Register selected for generic demand calculation
2401	Unit Code Generic Channel #1	—	—	-32,767 – 32,767	Used by software
2402	Scale Code Generic Channel #1	—	—	-3 – 3	
2403	Last Demand Generic Channel #1	—	—	0 – 32,767	
2404	Present Demand Generic Channel #1	—	—	0 – 32,767	
2405	Running Average Demand Generic Channel #1	—	—	0 – 32,767	Updated every second
2406	Peak Demand Generic Channel #1	—	—	0 – 32,767	

Table A–3: Abbreviated Register List

Reg	Name	Scale	Units	Range	Notes
2407	Peak Demand Date/Time Generic Channel #1	—	Table A–1 on page 107	Table A–1 on page 107	
2411	Minimum Demand Generic Channel #1	—	—	0 – 32,767	
2412	Minimum Demand Date/Time Generic Channel #1	—	Table A–1 on page 107	Table A–1 on page 107	
2420	Generic Channel #2				Same as registers 2400 – 2419 except for Channel #2
2440	Generic Channel #3				Same as registers 2400 – 2419 except for Channel #3
2460	Generic Channel #4				Same as registers 2400 – 2419 except for Channel #4
2480	Generic Channel #5				Same as registers 2400 – 2419 except for Channel #5
2500	Generic Channel #6				Same as registers 2400 – 2419 except for Channel #6
2520	Generic Channel #7				Same as registers 2400 – 2419 except for Channel #7
2540	Generic Channel #8				Same as registers 2400 – 2419 except for Channel #8
2560	Generic Channel #9				Same as registers 2400 – 2419 except for Channel #9
2580	Generic Channel #10				Same as registers 2400 – 2419 except for Channel #10
Phase Extremes					
2800	Current, Highest Phase Value	A	Amps/Scale	0 – 32,767	Highest value of Phases A, B, C or N
2801	Current, Lowest Phase Value	A	Amps/Scale	0 – 32,767	Lowest value of Phases A, B, C or N
2802	Voltage, L-L, Highest Value	D	Volts/Scale	0 – 32,767	Highest value of Phases A-B, B-C or C-A
2803	Voltage, L-L, Lowest Value	D	Volts/Scale	0 – 32,767	Lowest value of Phases A-B, B-C or C-A
2804	Voltage, L-N, Highest Value	D	Volts/Scale	0 – 32,767 (-32,768 if N/A)	Highest value of Phases A-N, B-N or C-N 4-wire system only
2805	Voltage, L-N, Lowest Value	D	Volts/Scale	0 – 32,767 (-32,768 if N/A)	Lowest value of Phases A-N, B-N or C-N 4-wire system only
System Configuration					
3002	Power Meter Nameplate	—	—	—	
3014	Power Meter Present Operating System Firmware Revision Level	—	—	0x0000 – 0xFFFF	

Table A-3: Abbreviated Register List

Reg	Name	Scale	Units	Range	Notes
3034	Present Date/Time	—	Table A-1 on page 107	Table A-1 on page 107	
3039	Last Unit Restart	—	Table A-1 on page 107	Table A-1 on page 107	Last unit restart time
3043	Number of Metering System Restarts	—	1.0	0 – 32,767	
3044	Number of Control Power Failures	—	1.0	0 – 32,767	
3045	Control Power Failure Date/Time	—	Table A-1 on page 107	Table A-1 on page 107	Date/Time of last control power failure
3049	Cause of Last Meter Reset	—	—	1 – 20	1 = shutdown & soft reset (restart F/W) 2 = shutdown & hard reset (load from flash and run) 3 = shutdown & hard reset and set memory to default 10 = shutdown with no reset (used by DLF) 12 = already shutdown, hard reset only (used by DLF) 20 = Power failure
3050	Self-Test Results	—	—	0x0000 – 0xFFFF	0 = Normal; 1 = Error Bit 00 = Is set to "1" if any failure occurs Bit 01 = RTC failure Bit 02 = Reserved Bit 03 = Reserved Bit 04 = Reserved Bit 05 = Metering Collection overrun failure Bit 06 = Reserved Bit 07 = Metering Process 1.0 overrun failure Bit 08 = Reserved Bit 09 = Reserved Bit 10 = Reserved Bit 11 = Reserved Bit 12 = Reserved Bit 13 = Reserved Bit 14 = Reserved Bit 15 = Reserved

Table A-3: Abbreviated Register List

Reg	Name	Scale	Units	Range	Notes
3051	Self Test Results	—	—	0x0000 – 0xFFFF	0 = Normal; 1 = Error Bit 00 = tbd Aux I/O failure Bit 01 = tbd Option Slot A module failure Bit 02 = tbd Option Slot B module failure Bit 03 = Bit 04 = Bit 05 = Bit 06 = Bit 07 = Bit 08 = OS Create failure Bit 09 = OS Queue overrun failure Bit 10 = Bit 11 = Bit 12 = Bit 13 = Systems shut down due to continuous reset Bit 14 = Unit in Download, Condition A Bit 15 = Unit in Download, Condition B
3052	Configuration Modified	—	—	0x0000 – 0xFFFF	Used by sub-systems to indicate that a value used within that system has been internally modified 0 = No modifications; 1 = Modifications Bit 00 = Summary bit Bit 01 = Metering System Bit 02 = Communications System Bit 03 = Alarm System Bit 04 = File System Bit 05 = Auxiliary I/O System Bit 06 = Display System
3093	Present Month	—	Months	1 – 12	
3094	Present Day	—	Days	1 – 31	
3095	Present Year	—	Years	2,000 – 2,043	
3096	Present Hour	—	Hours	0 – 23	
3097	Present Minute	—	Minutes	0 – 59	
3098	Present Second	—	Seconds	0 – 59	
3099	Day of Week	—	1.0	1 – 7	Sunday = 1

Table A-3: Abbreviated Register List

Reg	Name	Scale	Units	Range	Notes
Current/Voltage Configuration					
3138	CT Ratio, Phase A Correction Factor	—	0.00001	-20,000 – 20,000	Default = 0
3139	CT Ratio, Phase B Correction Factor	—	0.00001	-20,000 – 20,000	Default = 0
3140	CT Ratio, Phase C Correction Factor	—	0.00001	-20,000 – 20,000	Default = 0
3142	PT Ratio, Phase A Correction Factor	—	0.00001	-20,000 – 20,000	Default = 0
3143	PT Ratio, Phase B Correction Factor	—	0.00001	-20,000 – 20,000	Default = 0
3144	PT Ratio, Phase C Correction Factor	—	0.00001	-20,000 – 20,000	Default = 0
3150	Field Calibration Date/Time	—	Table A-1 on page 107	Table A-1 on page 107	
3154	Phase A Current Field Calibration Coefficient	—	0.00001	-20,000 – 20,000	Default = 0
3155	Phase B Current Field Calibration Coefficient	—	0.00001	-20,000 – 20,000	Default = 0
3156	Phase C Current Field Calibration Coefficient	—	0.00001	-20,000 – 20,000	Default = 0
3158	Phase A Voltage Field Calibration Coefficient	—	0.00001	-20,000 – 20,000	Default = 0
3159	Phase B Voltage Field Calibration Coefficient	—	0.00001	-20,000 – 20,000	Default = 0
3160	Phase C Voltage Field Calibration Coefficient	—	0.00001	-20,000 – 20,000	Default = 0
3161	Neutral-Ground Voltage Field Calibration Coefficient	—	0.00001	-20,000 – 20,000	Default = 0
3170	CT Phase Shift Correction @ 1 amp	—	—	-1,000 – 1,000	Phase Shift Correction in the range of -10° to $+10^\circ$. A negative shifts in the lag direction. Default = 0
3171	CT Phase Shift Correction @ 5 amps	—	—	-1,000 – 1,000	Phase Shift Correction in the range of -10° to $+10^\circ$. A negative shifts in the lag direction. Default = 0

Table A-3: Abbreviated Register List

Reg	Name	Scale	Units	Range	Notes
Metering Configuration and Status					
Metering Configuration and Status — Basic					
3200	Metering System Type	—	1.0	30, 31, 40, 42	30 = 3PH3W2CT 31 = 3PH3W3CT 40 = 3PH4W3CT (default) 42 = 3PH4W3CT2PT
3201	CT Ratio, 3-Phase Primary	—	1.0	1 – 32,767	Default = 5
3202	CT Ratio, 3-Phase Secondary	—	1.0	1, 5	Default = 5
3205	PT Ratio, 3-Phase Primary	—	1.0	1 – 32,767	Default = 120
3206	PT Ratio, 3-Phase Primary Scale Factor	—	1.0	-1 – 2	Default = 0 -1 = Direct Connect
3207	PT Ratio, 3-Phase Secondary	—	1.0	100, 110, 115, 120	Default = 120
3208	Nominal System Frequency	—	Hz	50, 60, 400	Default = 60
3209	Scale A – 3 Phase Amps	—	1.0	-2 – 1	Power of 10 Default = 0
3210	Scale B – Neutral Amps	—	1.0	-2 – 1	Power of 10 Default = 0
3212	Scale D – 3 Phase Volts	—	1.0	-1 – 2	Power of 10 Default = 0
3213	Scale E – Neutral Volts	—	1.0	-2 – 2	Power of 10 Default = -1
3214	Scale F – Power	—	1.0	-3 – 3	Power of 10 Default = 0

Table A-3: Abbreviated Register List

Reg	Name	Scale	Units	Range	Notes
3227	Operating Mode Parameters	—	Binary	0x0000 – 0x0FFF	Default = 0 Bit 00 = Reserved Bit 01 = Reactive Energy & Demand Accumulation 0 = Fund. Only; 1 = Harmonics Included Bit 02 = PF Sign Convention 0 = IEEE Convention 1 = IEC Convention Bit 03 = Reserved Bit 04 = Reserved Bit 05 = Reserved Bit 06 = Conditional Energy Accumulation Control 0 = Inputs; 1 = Command Bit 07 = Reserved Bit 08 = Display Setup 0 = Enabled 1 = Disabled Bit 09 = Normal Phase Rotation 0 = ABC 1 = CBA Bit 10 = Total Harmonic Distortion Calculation 0 = THD (% Fundamental) 1 = thd (% Total RMS) Bit 11 = Reserved
3228	Phase Rotation Direction	—	1.0	0 – 1	0 = ABC 1 = CBA
3229	Incremental Energy Interval	—	Minutes	0 – 1440	Default = 60 0 = Continuous Accumulation
3230	Incremental Energy Interval Start Time	—	Minutes	0 – 1440	Minutes from midnight Default = 0
3231	Incremental Energy Interval End Time	—	Minutes	0 – 1440	Minutes from midnight Default = 1440
3232	Energy Accumulation Mode	—	1.0	0 – 1	0 = Absolute (default) 1 = Signed
3233	Peak Current Demand Over Last Year (currently not calculated)	—	Amps	0 – 32,767	Entered by the user for use in calculation of Total Demand Distortion. 0 = Calculation not performed (default)

Table A-3: Abbreviated Register List

Reg	Name	Scale	Units	Range	Notes
Metering Configuration and Status — Harmonics (PM810 with a PM810LOG)					
3240	Harmonic Quantity Selection	—	1.0	0 – 3	0 = Disabled 1 = Harmonic magnitudes only (default) 2 = Harmonic magnitudes and angles
3241	Voltage Harmonic Magnitude Format	—	1.0	0 - 2	0 = % of Fundamental (default) 1 = % of RMS 2 = RMS
3242	Current Harmonic Magnitude Format	—	1.0	0 - 2	0 = % of Fundamental (default) 1 = % of RMS 2 = RMS
3243	Harmonic Refresh Interval	—	Seconds	10 – 60	Default = 30
3244	Time Remaining Until Harmonic Refresh	—	Seconds	10 – 60	The user may write to this register to stretch the hold time.
3245	Harmonic Channel Map	—	Binary	0x0000 – 0x7FFF	Bitmap indicating active Harmonic Channels 0 = Inactive 1 = Active Bit 00 = Vab Bit 01 = Vbc Bit 02 = Vca Bit 03 = Van Bit 04 = Vbn Bit 05 = Vcn Bit 06 = Reserved (Neutral to Ref) Bit 07 = Ia Bit 08 = Ib Bit 09 = Ic Bit 10 = In Bit 11-15 = Reserved
3246	Harmonic Report Status	—	1.0	0 – 1	0 = Processing (default) 1 = Holding
3248	Display 1 second Metering Floating Point Values	—	—	0 – 1	0 = Disabled (default) 1 = Enabled Values begin at register 11700

Table A-3: Abbreviated Register List

Reg	Name	Scale	Units	Range	Notes
Metering Configuration and Status — Diagnostics					
3254	Metering System Diagnostic Summary	—	Binary	0x0000 – 0xFFFF	0 = Normal 1 = Error Bit 00 = Summary Bit (On if any other bit is on) Bit 01 = Configuration Error Bit 02 = Scaling Error Bit 03 = Phase Loss Bit 04 = Wiring Error Bit 05 = Incremental Energy may be incorrect due to meter reset Bit 06 = External Demand Sync Timeout
3255	Metering System Configuration Error Summary	—	Binary	0x0000 – 0xFFFF	0 = Normal 1 = Error Bit 00 = Summary Bit (On if any other bit is on) Bit 01 = Logical Configuration Error Bit 02 = Demand System Configuration Error Bit 03 = Energy System Configuration Error Bit 04 = Reserved Bit 05 = Metering Configuration Error
3257	Wiring Error Detection 1	—	Binary	0x0000 – 0xFFFF	0 = Normal 1 = Error Bit 00 = Summary Bit (On if any other bit is on) Bit 01 = Wiring Check Aborted Bit 02 = System type setup error Bit 03 = Frequency out of range Bit 04 = No voltage Bit 05 = Voltage imbalance Bit 06 = Not enough load to check connections Bit 07 = Check meter configured for direct connect Bit 08 = All CT reverse polarity Bit 09 = Reserved Bit 10 = Reserved Bit 11 = Reserved Bit 12 = Reserved Bit 13 = Reserved Bit 14 = Phase rotation not as expected Bit 15 = Negative kW is usually abnormal

Table A–3: Abbreviated Register List

Reg	Name	Scale	Units	Range	Notes
3258	Wiring Error Detection 2	—	Binary	0x0000 – 0xFFFF	0 = Normal 1 = Error Bit 00 = Van magnitude error Bit 01 = Vbn magnitude error Bit 02 = Vcn magnitude error Bit 03 = Vab magnitude error Bit 04 = Vbc magnitude error Bit 05 = Vca magnitude error Bit 06 = Van angle not as expected Bit 07 = Vbn angle not as expected Bit 08 = Vcn angle not as expected Bit 09 = Vab angle not as expected Bit 10 = Vbc angle not as expected Bit 11 = Vca angle not as expected Bit 12 = Vbn is reversed polarity Bit 13 = Vcn is reversed polarity Bit 14 = Vbc is reversed polarity Bit 15 = Vca is reversed polarity
3259	Wiring Error Detection 3	—	Binary	0x0000 – 0xFFFF	0 = Normal 1 = Error Bit 00 = Move VTa to VTb Bit 01 = Move VTb to VTc Bit 02 = Move VTc to VTa Bit 03 = Move VTa to VTc Bit 04 = Move VTb to VTa Bit 05 = Move VTc to VTb Bit 06 = Reserved Bit 07 = Reserved Bit 08 = Reserved Bit 09 = Reserved Bit 10 = Ia is < 1% of CT Bit 11 = Ib is < 1% of CT Bit 12 = Ic is < 1% of CT Bit 13 = Ia angle not in expected range Bit 14 = Ib angle not in expected range Bit 15 = Ic angle not in expected range

Table A-3: Abbreviated Register List

Reg	Name	Scale	Units	Range	Notes
3260	Wiring Error Detection 4	—	Binary	0x0000 – 0xFFFF	0 = Normal 1 = Error Bit 00 = CTa reversed polarity Bit 01 = CTb reversed polarity Bit 02 = CTc reversed polarity Bit 03 = Reserved Bit 04 = Move CTa to CTb Bit 05 = Move CTb to CTc Bit 06 = Move CTc to Cta Bit 07 = Move CTa to CTc Bit 08 = Move CTb to Cta Bit 09 = Move CTc to CTb Bit 10 = Move CTa to CTb & reverse polarity Bit 11 = Move CTb to CTc & reverse polarity Bit 12 = Move CTc to CTa & reverse polarity Bit 13 = Move CTa to CTc & reverse polarity Bit 14 = Move CTb to CTa & reverse polarity Bit 15 = Move CTc to CTb & reverse polarity
3261	Scaling Error	—	Binary	0x0000 – 0x003F	Indicates potential over range due to scaling error 0 = Normal 1 = Error Bit 00 = Summary Bit (On if any other bit is on) Bit 01 = Scale A – Phase Current Error Bit 02 = Scale B – Neutral Current Error Bit 03 = Unused Bit 04 = Scale D – Phase Voltage Error Bit 05 = Scale E – Neutral Voltage Error Bit 06 = Scale F – Power Error

Table A-3: Abbreviated Register List

Reg	Name	Scale	Units	Range	Notes
3262	Phase Loss Bitmap	—	Binary	0x0000 – 0x007F (-32,768 if N/A)	<p>0 = OK 1 = Phase Loss</p> <p>Bit 00 = Summary Bit (On if any other bit is on) Bit 01 = Voltage Phase A Bit 02 = Voltage Phase B Bit 03 = Voltage Phase C Bit 04 = Current Phase A Bit 05 = Current Phase B Bit 06 = Current Phase C</p> <p>This register is controlled by the voltage and current phase loss alarms. These alarms must be configured and enabled for this register to be populated.</p>
Metering Configuration and Status — Resets					
3266	Previous Month Minimum/Maximum Start Date/Time	—	Table A-1 on page 107	Table A-1 on page 107	
3270	Present Month Minimum/Maximum Reset Date/Time	—	Table A-1 on page 107	Table A-1 on page 107	
3274	Accumulated Energy Reset Date/Time	—	Table A-1 on page 107	Table A-1 on page 107	
3278	Conditional Energy Reset Date/Time	—	Table A-1 on page 107	Table A-1 on page 107	
3282	Incremental Energy Reset Date/Time	—	Table A-1 on page 107	Table A-1 on page 107	
3286	Input Metering Accumulation Reset Date/Time	—	Table A-1 on page 107	Table A-1 on page 107	
3290	Accumulated Energy Preset Date/Time	—	Table A-1 on page 107	Table A-1 on page 107	

Table A-3: Abbreviated Register List

Reg	Name	Scale	Units	Range	Notes
Communications					
Communications — RS485					
3400	Protocol	—	—	0 – 2	0 = Modbus (default) 1 = Jbus
3401	Address	—	—	0 – 255	Valid Addresses: (Default = 1) Modbus: 0 – 247 Jbus: 0 – 255
3402	Baud Rate	—	—	0 – 5	3 = 9600 (default) 4 = 19200 5 = 38400
3403	Parity	—	—	0 – 2	0 = Even (default) 1 = Odd 2 = None
3410	Packets To This Unit	—	—	0 – 32,767	Number of valid messages addressed to this unit
3411	Packets To Other Units	—	—	0 – 32,767	Number of valid messages addressed to other units
3412	Packets With Invalid Address	—	—	0 – 32,767	Number of messages received with invalid address
3413	Packets With Bad CRC	—	—	0 – 32,767	Number of messages received with bad CRC
3414	Packets With Error	—	—	0 – 32,767	Number of messages received with errors
3415	Packets With Illegal Opcode	—	—	0 – 32,767	Number of messages received with an illegal opcode
3416	Packets With Illegal Register	—	—	0 – 32,767	Number of messages received with an illegal register
3417	Invalid Write Responses	—	—	0 – 32,767	Number of invalid write responses
3418	Packets With Illegal Counts	—	—	0 – 32,767	Number of messages received with an illegal count
3419	Packets With Frame Error	—	—	0 – 32,767	Number of messages received with a frame error
3420	Broadcast Messages	—	—	0 – 32,767	Number of broadcast messages received
3421	Number Of Exceptions	—	—	0 – 32,767	Number of exception replies
3422	Messages With Good CRC	—	—	0 – 32,767	Number of messages received with a good CRC
3423	Modbus Event Counter	—	—	0 – 32,767	Modbus Event Counter

Table A-4: Registers for Inputs and Outputs

Reg	Name	Scale	Units	Range	Notes
Auxiliary Inputs and Outputs					
4000	Discrete Input Status Standard Discrete Input	—	—	—	0 = Off 1 = On Bit 00 = Not Used Bit 01 = Standard discrete input I/O Point 2 Remaining bits unused
4000	Discrete Input Status Standard Discrete Input	—	—	—	0 = Off 1 = On Bit 00 = Not Used Bit 01 = Standard discrete input I/O Point 2 Remaining bits unused
4001	Discrete Input Status Position A	—	—	0x0000 – 0xFFFF	0 = Off 1 = On Bit 00 = On/Off Status of I/O Point 3 Bit 01 = On/Off Status of I/O Point 4 Bit 02 = On/Off Status of I/O Point 5 Bit 03 = On/Off Status of I/O Point 6 Bit 04 = On/Off Status of I/O Point 7 Bit 05 = On/Off Status of I/O Point 8 Bit 06 = On/Off Status of I/O Point 9 Bit 07 = On/Off Status of I/O Point 10 Remaining bits unused
4002	Discrete Input Status Position B	—	—	0x0000 – 0xFFFF	0 = Off 1 = On Bit 00 = On/Off Status of I/O Point 11 Bit 01 = On/Off Status of I/O Point 12 Bit 02 = On/Off Status of I/O Point 13 Bit 03 = On/Off Status of I/O Point 14 Bit 04 = On/Off Status of I/O Point 15 Bit 05 = On/Off Status of I/O Point 16 Bit 06 = On/Off Status of I/O Point 17 Bit 07 = On/Off Status of I/O Point 18 Remaining bits unused
4003	Reserved	—	—	—	Reserved for future development

Table A-4: Registers for Inputs and Outputs

Reg	Name	Scale	Units	Range	Notes
4005	Discrete Output Status Standard Discrete Output	—	—	0x0000 – 0x0001	0 = Off 1 = On Bit 00 = Standard discrete output, I/O Point 1 Remaining bits unused
4006	Discrete Output Status Position A	—	—	0x0000 – 0xFFFF	0 = Off 1 = On Bit 00 = On/Off Status of I/O Point 3 Bit 01 = On/Off Status of I/O Point 4 Bit 02 = On/Off Status of I/O Point 5 Bit 03 = On/Off Status of I/O Point 6 Bit 04 = On/Off Status of I/O Point 7 Bit 05 = On/Off Status of I/O Point 8 Bit 06 = On/Off Status of I/O Point 9 Bit 07 = On/Off Status of I/O Point 10 Remaining bits unused
4007	Discrete Output Status Position B	—	—	0x0000 – 0xFFFF	0 = Off 1 = On Bit 00 = On/Off Status of I/O Point 11 Bit 01 = On/Off Status of I/O Point 12 Bit 02 = On/Off Status of I/O Point 13 Bit 03 = On/Off Status of I/O Point 14 Bit 04 = On/Off Status of I/O Point 15 Bit 05 = On/Off Status of I/O Point 16 Bit 06 = On/Off Status of I/O Point 17 Bit 07 = On/Off Status of I/O Point 18 Remaining bits unused
4008	Reserved	—	—	—	Reserved for future development
4010	IO System Diagnostic Summary	—	—	0x0000 – 0x007F	0 = OK 1 = Error Bit 00 = Summary bit Bit 01 = I/O Error – Standard Bit 02 = I/O Error – I/O Position A Bit 03 = I/O Error – I/O Position B Remaining bits unused

Table A-4: Registers for Inputs and Outputs

Reg	Name	Scale	Units	Range	Notes
4011	IO Module Health Status Standard IO	—	—	0x0000 – 0x000F	0 = OK 1 = Error Bit 00 = Module error summary Bit 01 = Point error summary Bit 02 = Module removed while meter is running Bit 03 = Module change validation failed Remaining bits unused
4012	IO Module Health Status Position A	—	—	0x0000 – 0x000F	0 = OK 1 = Error Bit 00 = Module error summary Bit 01 = Point error summary Bit Bit 02 = Module removed while meter is running Bit 03 = Module change validation failed Remaining bits unused
4013	IO Module Health Status Position B	—	—	0x0000 – 0x000F	0 = OK 1 = Error Bit 00 = Module error summary Bit 01 = Point error summary Bit Bit 02 = Module removed while meter is running Bit 03 = Module change validation failed Remaining bits unused
4014	Reserved	—	—	—	Reserved for future development
4020	Present Module Type Standard IO	—	—	255	Should always be 255
4021	Present Module Type Position A	—	—	0 – 7	0 = Not Installed 1 = Reserved 2 = IO-22 3 = IO-26 4 = IO-2222
4022	Present Module Type Position B	—	—	0 – 7	0 = Not Installed 1 = Reserved 2 = IO-22 3 = IO-26 4 = IO-2222
4023	Extended MBUS Device	—	—	—	0x39 = Logging Module
4024	Reserved	—	—	—	Reserved for future development
4025	Previous Module Type Standard IO	—	—	255	Should always be 255

Table A-4: Registers for Inputs and Outputs

Reg	Name	Scale	Units	Range	Notes
4026	Previous Module Type Position A	—	—	0 – 7	Indicates the I/O option module present the last time the meter was reset. 0 = Not Installed 1 = Reserved 2 = IO-22 3 = IO-26 4 = IO-2222
4027	Previous Module Type Position B	—	—	0 – 7	Indicates the I/O option module present the last time the meter was reset. 0 = Not Installed 1 = Reserved 2 = IO-22 3 = IO-26 4 = IO-2222
4028	Reserved	—	—	—	Reserved for future development
4030	Last Module Type Standard IO	—	—	255	Should always be 255
4031	Last Module Type Position A	—	—	0 – 7	Indicates the last valid I/O module type successfully installed 0 = Not Installed 1 = Reserved 2 = IO-22 3 = IO-26 4 = IO-2222
4032	Last Module Type Position B	—	—	0 – 7	Indicates the last valid I/O module type successfully installed 0 = Not Installed 1 = Reserved 2 = IO-22 3 = IO-26 4 = IO-2222
4033	Reserved	—	—	—	Reserved for future development
4080	Reserved	—	—	—	Reserved for future development
4081	Hardware Revision Number Analog I/O Option Module Position A	—	—	ASCII/HEX	4 ASCII bytes

Table A-4: Registers for Inputs and Outputs

Reg	Name	Scale	Units	Range	Notes
4083	Firmware Revision Number Analog I/O Option Module Position A	—	—		
4084	Date/Time of Mfg and/or Calibration Analog I/O Option Module Position A	—	—		
4087	Reserved	—	—	—	Reserved for future development
4088	Serial Number Analog I/O Option Module Position A	—	—		
4090	Process Registers Analog I/O Option Module Position A	—	—		
4100	Reserved	—	—	—	Reserved for future development
4101	Hardware Revision Number Analog I/O Option Module Position B	—	—	ASCII	4 ASCII bytes
4103	Firmware Revision Number Analog I/O Option Module Position B	—	—		
4104	Date/Time of Mfg and/or Calibration Analog I/O Option Module Position B	—	—		
4107	Reserved	—	—	—	Reserved for future development
4108	Serial Number Analog I/O Option Module Position B	—	—		
4110	Process Registers Analog I/O Option Module Position B	—	—		
4111	Reserved	—	—	—	Reserved for future development

Table A-4: Registers for Inputs and Outputs

Reg	Name	Scale	Units	Range	Notes
4200	Discrete Output/Alarm Table	—	—	0 – 4682	Table of discrete output/alarm associations. Upper byte is the I/O Point Number (1 – 18). Lower byte is the Alarm Index Number (1 – 74).
Standard and Option Modules					
4300	IO Point Number 1 Standard Discrete Output I/O point 1				Refer to Discrete Output template below.
4330	IO Point Number 2 Standard Discrete Input I/O point 2				Refer to Discrete Input template below.
4360	IO Point Number 3				Register contents depend on the I/O Point Type. Refer to the I/O templates in this table.
4390	IO Point Number 4				Register contents depend on the I/O Point Type. Refer to the I/O templates in this table.
4420	IO Point Number 5				Register contents depend on the I/O Point Type. Refer to the I/O templates in this table.
4450	IO Point Number 6				Register contents depend on the I/O Point Type. Refer to the I/O templates in this table.
4480	IO Point Number 7				Register contents depend on the I/O Point Type. Refer to the I/O templates in this table.
4510	IO Point Number 8				Register contents depend on the I/O Point Type. Refer to the I/O templates in this table.
4540	IO Point Number 9				Register contents depend on the I/O Point Type. Refer to the I/O templates in this table.
4570	IO Point Number 10				Register contents depend on the I/O Point Type. Refer to the I/O templates in this table.
4600	IO Point Number 11				Register contents depend on the I/O Point Type. Refer to the I/O templates in this table.
4630	IO Point Number 12				Register contents depend on the I/O Point Type. Refer to the I/O templates in this table.
4660	IO Point Number 13				Register contents depend on the I/O Point Type. Refer to the I/O templates in this table.
4690	IO Point Number 14				Register contents depend on the I/O Point Type. Refer to the I/O templates in this table.
4720	IO Point Number 15				Register contents depend on the I/O Point Type. Refer to the I/O templates in this table.
4750	IO Point Number 16				Register contents depend on the I/O Point Type. Refer to the I/O templates in this table.
4780	IO Point Number 17				Register contents depend on the I/O Point Type. Refer to the I/O templates in this table.
4810	IO Point Number 18				Register contents depend on the I/O Point Type. Refer to the I/O templates in this table.

Table A–4: Registers for Inputs and Outputs

Reg	Name	Scale	Units	Range	Notes
4840	Reserved	—	—	—	Reserved for future development
Discrete Input Template					
Base	IO Point Type	—	—	100 – 199	<ul style="list-style-type: none"> • First digit (1) indicates point is discrete input • Second digit indicates module type 0 = Generic discrete input • Third digit indicates input type 1 = Unused 2 = AC/DC
Base +1	IO Point Label	—	—	ASCII	16 Characters
Base +9	Discrete Input Operating Mode	—	—	0 – 3	<p>0 = Normal (default) 1 = Demand Interval Sync Pulse 2 = N/A 3 = Conditional Energy Control 4 = Input Metering, used only with external option modules</p> <p>Only one Time Sync input and one Conditional Energy Control are allowed. If the user attempts to configure more than one of each of these modes, the lowest I/O Point Number takes precedence. The modes of the other points will be set to default.</p>
Base +10	Demand Interval Sync System Assignments	—	—	0x0000 – 0x001F	<p>Bitmap indicating Demand System(s) to which input is assigned. (Default = 0) Bit 00 = Power Demand Bit 01 = Current Demand Bit 02 = NA Bit 03 = Input Metering Demand Bit 04 = Generic Demand 1</p> <p>Only one Demand Sync Pulse is allowed per Demand System. If the user attempts to configure more than one input for each system, the lowest I/O Point Number takes precedence. The corresponding bits of the other points are set to 0.</p>
Base +11	Reserved	—	—	—	Reserved for future development
Base +14	Metering Pulse Channel Assignments	—	—	0x0000 – 0x001F	<p>Up to 5 channels are supported Default = 0 Bit 00 = Channel 1 Bit 01 = Channel 2 Bit 02 = Channel 3 Bit 03 = Channel 4 Bit 04 = Channel 5 Bit 05 – 15 Unused</p>

Table A–4: Registers for Inputs and Outputs

Reg	Name	Scale	Units	Range	Notes
Base +15	Metering Pulse Weight Demand	—	1.0	1– 32,767	Pulse weight associated with the change of state of the input. Used for demand metering. (Default = 1)
Base +16	Metering Pulse Scale Factor Demand	—	1.0	-3 – 3	Pulse weight scale factor (power of 10) to apply to metering pulse weight. Used for demand metering. (Default = 0)
Base +17	Metering Pulse Weight Consumption	—	1.0	1– 32,767	Pulse weight associated with the change of state of the input. Used for consumption metering. (Default = 1)
Base +18	Metering Pulse Scale Factor Consumption	—	1.0	-3 – 3	Pulse weight scale factor (power of 10) to apply to metering pulse weight. Used for consumption metering. (Default = 0)
Base +19	Consumption Units Code	—	See Template	0 - 100	Defines the units associated with the Consumption Pulse Weight/Scale (Default = 0)
Base +20	Reserved	—	—	—	Reserved for future development
Base +22	IO Point Diagnostic Bitmap	—	—	0x0000 – 0xFFFF	0 = OK, 1 = Error Bit 00 = I/O Point diagnostic summary Bit 01 = Configuration invalid – default value used
Base +23	Reserved	—	—	—	Reserved for future development
Base +25	Discrete Input On/Off Status	—	—	0 – 1	0 = Off 1 = On
Base +26	Count	—	—	0 – 99,999,999	Number of times input has transitioned from Off to On
Base +28	On Time	—	Seconds	0 – 99,999,999	Duration that discrete input has been On
Discrete Output Template					
Base	IO Point Type	—	—	200 – 299	<ul style="list-style-type: none"> First digit (2) indicates point is discrete output Second digit indicates module type 0 = Generic discrete output Third digit indicates output type 1 = solid state relay 2 = electromechanical relay
Base +1	IO Point Label	—	—	ASCII	16 Characters

Table A-4: Registers for Inputs and Outputs

Reg	Name	Scale	Units	Range	Notes
Base +9	Discrete Output Operating Mode	—	—	0 – 11	<p>0 = Normal (default) 1 = Latched 2 = Timed 11 = End of power demand interval</p> <p>The following modes are only supported by the standard output (KY). No support is provided for the I/O option modules:</p> <p>3 = Absolute kWh pulse 4 = Absolute kVARh pulse 5 = kVAh pulse 6 = kWh In pulse 7 = kVARh In pulse 8 = kWh out pulse 9 = kVARh out pulse 10 = Register-based pulse (future)</p>
Base +10	On Time For Timed Mode	—	Seconds	1 – 32,767	The time for the output to remain energized when the output is in timed mode or end of power demand interval. (Default = 1)
Base +11	Pulse Weight	—	kWh / Pulse kVARh / Pulse kVAh / Pulse in 100ths	1 – 32,767	Specifies the kWh, kVARh and kVAh per pulse for output when in these modes. (Default = 1)
Base +12	Internal/External Control	—	—	0 – 1	0 = Internal Control 1 = External Control (default)
Base +13	Normal/Override Control	—	—	0 – 1	0 = Normal Control (default) 1 = Override Control
Base +14	Reference Register	—	—	—	Reserved for future development
Base +15	Reserved	—	—	—	Reserved for future development
Base +16	Reserved	—	—	—	Reserved for future development
Base +17	Reserved	—	—	—	Reserved for future development
Base +18	Reserved	—	—	—	Reserved for future development
Base +19	Reserved	—	—	—	Reserved for future development
Base +20	Reserved	—	—	—	Reserved for future development
Base +21	State of Discrete Output at Reset	—	—	0 – 1	Indicates On/Off state of the discrete output when meter reset/shutdown occurs

Table A-4: Registers for Inputs and Outputs

Reg	Name	Scale	Units	Range	Notes
Base +22	IO Point Diagnostic Bitmap	—	—	0x0000 – 0x000F	0 = OK, 1 = Error Bit 00 = I/O Point diagnostic summary Bit 01 = Configuration invalid – default value used Bit 02 = Discrete output energy pulse – time between transitions exceeds 30 seconds Bit 03 = Discrete output energy pulse – time between transitions limited to 20 milliseconds
Base +23	Reserved	—	—	—	Reserved for future development
Base +24	Reserved	—	—	—	Reserved for future development
Base +25	Discrete Output On/Off Status	—	—	0 – 1	0 = Off 1 = On
Base +26	Count	—	—	0 – 99,999,999	Number of times output has transitioned from OFF to ON
Base +28	On Time	—	Seconds	0 – 99,999,999	Duration that discrete output has been ON

Table A-4: Registers for Inputs and Outputs

Reg	Name	Scale	Units	Range	Notes
Analog Input Template					
Base	IO Point Type	—	—	300 – 399	<ul style="list-style-type: none"> First digit (3) = point is analog input Second digit = range of analog I/O values (used without units) <ul style="list-style-type: none"> 0 = 0 – 1 1 = 0 – 5 2 = 0 – 10 3 = 0 – 20 4 = 1 – 5 5 = 4 – 20 6 = -5 – 5 7 = -10 – 10 8 = -100 – 100 9 = User defined (values default to 0) Third digit = digital resolution of the I/O hardware. The user must select from one of these standard ranges. <ul style="list-style-type: none"> 0 = 8-Bit, unipolar 1 = 10-Bit, unipolar 2 = 12-Bit, unipolar 3 = 14-Bit, unipolar 4 = 16-Bit, unipolar 5 = 16-Bit, bipolar with sign 6 = reserved 7 = reserved 8 = Resolution for IO2222 Voltage range 0 - 4000 9 = Resolution for IO2222 Current range 800 - 4000
Base +1	IO Point Label	—	—	ASCII	16 Characters
Base +9	Units Code	—	—	0 – 99	Placeholder for a code used by software to identify the SI units of the analog input being metered, i.e. kW, V, etc.
Base +10	Scale Code	—	—	-3 – 3	Placeholder for the scale code (power of 10) used by software to place the decimal point.
Base +11	Range Select	—	—	0 – 1	<p>Analog input gain select. Applies only to Option Module 2222.</p> <ul style="list-style-type: none"> 1 = Use calibration constants associated with current (Default) 0 = Use calibration constants associated with voltage
Base +12	Analog Input Minimum	—	—	0 – :32,767	Minimum value of the scaled register value for the analog input. (Only if Metering Register Number is not 0.)
Base +13	Analog Input Maximum	—	—	0 – :32,767	Maximum value of the scaled register value for the analog input. (Only if Metering Register Number is not 0.)

Table A-4: Registers for Inputs and Outputs

Reg	Name	Scale	Units	Range	Notes
Base +14	Lower Limit Analog Value	—	—	0 – ± 327	Lower limit of the analog input value. Default value based on I/O Point Type.
Base +15	Upper Limit Analog Value	—	—	0 – ± 327	Upper limit of the analog input value. Default value based on I/O Point Type.
Base +16	Lower Limit Register Value	—	—	0 – $\pm 32,767$	Lower limit of the register value associated with the lower limit of the analog input value.
Base +17	Upper Limit Register Value	—	—	0 – $\pm 32,767$	Upper limit of the register value associated with the upper limit of the analog input value.
Base +18	Reserved	—	—	—	Reserved for future development
Base +19	User Gain Adjustment	—	0.0001	8,000 – 12,000	Analog input user gain adjustment in 100ths of a percent. Default = 10,000.
Base +20	User Offset Adjustment	—	—	0 – $\pm 30,000$	Analog input user offset adjustment in Bits of digital resolution. Default = 0.
Base +21	Reserved	—	—	—	Reserved for future development
Base +22	IO Point Diagnostic Bitmap	—	—	0x0000 – 0x0007	0 = OK, 1 = Error Bit 00 = I/O Point diagnostic summary Bit 01 = Configuration invalid – default value used
Base +23	Lower Limit Digital Value	—	—	0 – $\pm 32,767$	Lower limit of the digital value associated with the lower limit of the analog input value. Value based on I/O Point Type.
Base +24	Upper Limit Digital Value	—	—	0 – $\pm 32,767$	Upper limit of the digital value associated with the upper limit of the analog input value. Value based on I/O Point Type.
Base +25	Present Raw Value	—	—	0 – $\pm 32,767$	Raw digital value read from analog input.
Base +26	Present Scaled Value	—	—	0 – $\pm 32,767$	Raw value corrected by calibration gain and offset adjustments and scaled based on range of register values.
Base +27	Calibration Offset	—	—	0 – $\pm 32,767$	Analog input offset adjustment
Base +28	Calibration Gain (Voltage)	—	0.0001	8,000 – 12,000	Analog input gain adjustment
Base +29	Calibration Gain (Current)	—	0.0001	8,000 – 12,000	Analog input gain adjustment

Table A-4: Registers for Inputs and Outputs

Reg	Name	Scale	Units	Range	Notes
Analog Output Template					
Base	IO Point Type	—	—	400 – 499	<ul style="list-style-type: none"> First digit (4) indicates point is analog output Second digit indicates the range of analog I/O values (used without units) <ul style="list-style-type: none"> 0 = 0 – 1 1 = 0 – 5 2 = 0 – 10 3 = 0 – 20 4 = 1 – 5 5 = 4 – 20 6 = -5 – 5 7 = -10 – 10 8 = -100 – 100 9 = User defined (values default to 0) Third digit indicates the digital resolution of the I/O hardware. The user must select from one of these standard ranges. <ul style="list-style-type: none"> 0 = 8-Bit, unipolar 1 = 10-Bit, unipolar 2 = 12-Bit, unipolar 3 = 14-Bit, unipolar 4 = 16-Bit, unipolar 5 = 16-Bit, bipolar with sign 6 = reserved 7 = reserved 8 = Resolution for IO2222 Voltage range 0 - 4000 9 = Resolution for IO2222 Current range 800 - 4000
Base +1	IO Point Label	—	—	ASCII	16 Characters
Base +9	Reserved	—	—	—	Reserved for future development
Base +10	Reserved	—	—	—	Reserved for future development
Base +11	Reserved	—	—	—	Reserved for future development
Base +12	Output Enable	—	—	0 – 1	<ul style="list-style-type: none"> 0 = Enable (default) 1 = Disable
Base +13	Reserved	—	—	—	Reserved for future development
Base +14	Lower Limit Analog Value	—	—	0 – ± 327	Lower limit of the analog output value. Default value based on I/O Point Type.
Base +15	Upper Limit Analog Value	—	—	0 – ± 327	Upper limit of the analog output value. Default value based on I/O Point Type.
Base +16	Lower Limit Register Value	—	—	0 – $\pm 32,767$	Lower limit of the register value associated with the lower limit of the analog output value.
Base +17	Upper Limit Register Value	—	—	0 – $\pm 32,767$	Upper limit of the register value associated with the upper limit of the analog output value.
Base +18	Reference Register Number	—	—	1000 – 32000	Register location of value upon which to base the analog output.

Table A-4: Registers for Inputs and Outputs

Reg	Name	Scale	Units	Range	Notes
Base +19	User Gain Adjustment	—	0.0001	8000 – 12,000	Analog output user gain adjustment in 100ths of a percent. Default = 10,000.
Base +20	User Offset Adjustment	—	—	0 – ±30000	Analog output user offset adjustment in Bits of digital resolution. Default = 0.
Base +21	Reserved	—	—	—	Reserved for future development
Base +22	I/O Point Diagnostic Bitmap	—	—	0x0000 – 0xFFFF	0 = OK, 1 = Error Bit 00 = I/O Point diagnostic summary Bit 01 = Configuration invalid – default value used
Base +23	Lower Limit Digital Value	—	—	0 – ±32,767	Lower limit of the digital value associated with the lower limit of the analog output value. Value based on I/O Point Type.
Base +24	Upper Limit Digital Value	—	—	0 – ±32,767	Upper limit of the digital value associated with the upper limit of the analog output value. Value based on I/O Point Type.
Base +25	Present Analog Value	—	0.01	0 – ±32,767	Analog value expected to be present at the output terminals of the analog output module.
Base +26	Present Raw (Register) Value	—	—	0 – ±32,767	Value in Reference Register.
Base +27	Calibration Offset	—	—	0 – ±32,767	Analog output offset adjustment in bits of digital resolution.
Base +28	Calibration Gain (Voltage)	—	0.0001	8000 – 12,000	Analog output gain adjustment in 100ths of a percent.
Base +29	Present Digital Value	—	—	—	

Table A-5: Registers for Alarm Logs

Reg	Name	Scale	Units	Range	Notes
Active Alarm Log					
5850	Acknowledge/Relay/Priority Entry 1	—	—		Bits 0 -7 = Alarm Number Bits 8 = Active/Inactive 0=active 1=inactive Bits 9-11 = Unused Bits 12-13 = Priority Bit 14 = relay (1 = association) Bit 15 = Alarm Acknowledge (1 = acknowledged)
5851	Unique Identifier	—	—	0 – 0xFFFFFFFF	Bits 00 – 07 = Level (0 – 9) Bits 08 – 15 = Alarm Type Bits 16 – 31 = Test Register
5853	Label	—	—	ASCII	16 Characters
5861	Pickup Value for Entry 1	A-F	Units/Scale	0 – 32,767	Does not apply to digital or unary alarms

Table A-5: Registers for Alarm Logs

Reg	Name	Scale	Units	Range	Notes
5862	Pickup Date/Time Entry 1	—	Table A-1 on page 107	Table A-1 on page 107	
5865	Active Alarm Log Entry 2				Same as 5850 – 5864 except for entry 2
5880	Active Alarm Log Entry 3				Same as 5850 – 5864 except for entry 3
5895	Active Alarm Log Entry 4				Same as 5850 – 5864 except for entry 4
5910	Active Alarm Log Entry 5				Same as 5850 – 5864 except for entry 5
5925	Active Alarm Log Entry 6				Same as 5850 – 5864 except for entry 6
5940	Active Alarm Log Entry 7				Same as 5850 – 5864 except for entry 7
5955	Active Alarm Log Entry 8				Same as 5850 – 5864 except for entry 8
5970	Active Alarm Log Entry 9				Same as 5850 – 5864 except for entry 9
5985	Active Alarm Log Entry 10				Same as 5850 – 5864 except for entry 10
6000	Active Alarm Log Entry 11				Same as 5850 – 5864 except for entry 11
6015	Active Alarm Log Entry 12				Same as 5850 – 5864 except for entry 12
6030	Active Alarm Log Entry 13				Same as 5850 – 5864 except for entry 13
6045	Active Alarm Log Entry 14				Same as 5850 – 5864 except for entry 14
6060	Active Alarm Log Entry 15				Same as 5850 – 5864 except for entry 15
6075	Active Alarm Log Entry 16				Same as 5850 – 5864 except for entry 16
6090	Active Alarm Log Entry 17				Same as 5850 – 5864 except for entry 17
6105	Active Alarm Log Entry 18				Same as 5850 – 5864 except for entry 18
6120	Active Alarm Log Entry 19				Same as 5850 – 5864 except for entry 19
6135	Active Alarm Log Entry 20				Same as 5850 – 5864 except for entry 20
6150	Active Alarm Log Entry 21				Same as 5850 – 5864 except for entry 21
6165	Active Alarm Log Entry 22				Same as 5850 – 5864 except for entry 22
6180	Active Alarm Log Entry 23				Same as 5850 – 5864 except for entry 23
6195	Active Alarm Log Entry 24				Same as 5850 – 5864 except for entry 24

Table A-5: Registers for Alarm Logs

Reg	Name	Scale	Units	Range	Notes
6210	Active Alarm Log Entry 25				Same as 5850 – 5864 except for entry 25
6225	Number of unacknowledged alarms in active alarm log	—	1.0	0 – 50	The number of active alarms added to the active alarm log since reset that have not been acknowledged
6226	Number of unacknowledged alarms in active alarm list	—	1.0	0 – 50	The number of alarms that have not been acknowledged since reset
Alarm History Log					
6250	Acknowledge/Relay/Priority Entry 1	—	—		Bits 0 - 7 = Alarm Number Bits 8-11 = Unused Bits 12-13 = Priority Bit 14 = relay (1 = association) Bit 15 = Alarm Acknowledged
6251	Unique Identifier	—	—	0 – 0xFFFFFFFF	Bits 00 – 07 = Level (0 – 9) Bits 08 – 15 = Alarm Type Bits 16 – 31 = Test Register
6253	Label	—	—	ASCII	16 Characters
6261	Extreme Value for History Log Entry 1	A-F	Units/Scale	0 – 32,767	Does not apply to digital or unary alarms
6262	Dropout Date/Time Entry 1	—	Table A-1 on page 107	Table A-1 on page 107	
6265	Elapsed Seconds for History Log Entry 1	—	Seconds	0 – 2147483647	
6267	Alarm History Log Entry 2				Same as 6250 – 6266 except for entry 2
6284	Alarm History Log Entry 3				Same as 6250 – 6266 except for entry 3
6301	Alarm History Log Entry 4				Same as 6250 – 6266 except for entry 4
6318	Alarm History Log Entry 5				Same as 6250 – 6266 except for entry 5
6335	Alarm History Log Entry 6				Same as 6250 – 6266 except for entry 6
6352	Alarm History Log Entry 7				Same as 6250 – 6266 except for entry 7
6369	Alarm History Log Entry 8				Same as 6250 – 6266 except for entry 8
6386	Alarm History Log Entry 9				Same as 6250 – 6266 except for entry 9
6403	Alarm History Log Entry 10				Same as 6250 – 6266 except for entry 10
6420	Alarm History Log Entry 11				Same as 6250 – 6266 except for entry 11

Table A-5: Registers for Alarm Logs

Reg	Name	Scale	Units	Range	Notes
6437	Alarm History Log Entry 12				Same as 6250 – 6266 except for entry 12
6454	Alarm History Log Entry 13				Same as 6250 – 6266 except for entry 13
6471	Alarm History Log Entry 14				Same as 6250 – 6266 except for entry 14
6488	Alarm History Log Entry 15				Same as 6250 – 6266 except for entry 15
6505	Alarm History Log Entry 16				Same as 6250 – 6266 except for entry 16
6522	Alarm History Log Entry 17				Same as 6250 – 6266 except for entry 17
6539	Alarm History Log Entry 18				Same as 6250 – 6266 except for entry 18
6556	Alarm History Log Entry 19				Same as 6250 – 6266 except for entry 19
6573	Alarm History Log Entry 20				Same as 6250 – 6266 except for entry 20
6590	Alarm History Log Entry 21				Same as 6250 – 6266 except for entry 21
6607	Alarm History Log Entry 22				Same as 6250 – 6266 except for entry 22
6624	Alarm History Log Entry 23				Same as 6250 – 6266 except for entry 23
6641	Alarm History Log Entry 24				Same as 6250 – 6266 except for entry 24
6658	Alarm History Log Entry 25				Same as 6250 – 6266 except for entry 25
6675	Number of unacknowledged alarms in alarm history log	—	1.0	0 – 50	The number of unacknowledged alarms added to the alarm history log since reset
6676	Lost Alarms	—	1.0	0 – 32767	The number of alarm pickups FIFOed from the internal active alarm list before a correlating pickup is received

Table A–6: Registers for Alarm Position Counters

Reg	Name	Scale	Units	Range	Notes
Alarms					
Alarms — System Status					
10011	Active Alarm Map	—	Binary	0x0000 – 0xFFFF	0 = Inactive, 1 = Active Bit00 = Alarm #01 Bit01 = Alarm #02etc.
10023	Active Alarm Status	—	Binary	0x0000 – 0x000F	Bit00 = 1 if any priority 1-3 alarm is active Bit01 = 1 if a "High" (1) priority alarm is active Bit02 = 1 if a "Medium" (2) priority alarm is active Bit03 = 1 if a "Low" (3) priority alarm is active
10024	Latched Active Alarm Status	—	Binary	0x0000 – 0x000F	Latched Active Alarms: (from the last time the register was cleared) Bit00 = 1 if any priority 1-3 alarm is active Bit01 = 1 if a "High" (1) priority alarm is active Bit02 = 1 if a "Medium" (2) priority alarm is active Bit03 = 1 if a "Low" (3) priority alarm is active
10025	Total Counter	—	1.0	0 – 32,767	Total alarm counter, including all priorities 1, 2 and 3
10026	P3 Counter	—	1.0	0 – 32,767	Low alarm counter, all priority 3s
10027	P2 Counter	—	1.0	0 – 32,767	Medium alarm counter, all priority 2s
10028	P1 Counter	—	1.0	0 – 32,767	High alarm counter, all priority 1s
10029	Pickup Mode Selection	—	Binary	0x0 – 0xFFFF	Selection of absolute or relative pickup test for each of the alarm positions (if applicable, based on type) Alarm #01 is least significant bit in register 10040 0 = Absolute (default) 1 = Relative Bit00 = Alarm #01 Bit01 = Alarm #02, etc.
10041	Number Of Samples In Relative Threshold Average	—	1.0	5 – 30	Number of 1-second update intervals used to compute the RMS average value used in relative pickup alarms (Default = 30)
Alarms — Counters					
10115	Alarm Position #001 Counter	—	1.0	0 – 32,767	Standard Speed Alarm Position #001
10116	Alarm Position #002 Counter	—	1.0	0 – 32,767	Standard Speed Alarm Position #002
10117	Alarm Position #003 Counter	—	1.0	0 – 32,767	Standard Speed Alarm Position #003

Table A–6: Registers for Alarm Position Counters

Reg	Name	Scale	Units	Range	Notes
10118	Alarm Position #004 Counter	—	1.0	0 – 32,767	Standard Speed Alarm Position #004
10119	Alarm Position #005 Counter	—	1.0	0 – 32,767	Standard Speed Alarm Position #005
10120	Alarm Position #006 Counter	—	1.0	0 – 32,767	Standard Speed Alarm Position #006
10121	Alarm Position #007 Counter	—	1.0	0 – 32,767	Standard Speed Alarm Position #007
10122	Alarm Position #008 Counter	—	1.0	0 – 32,767	Standard Speed Alarm Position #008
10123	Alarm Position #009 Counter	—	1.0	0 – 32,767	Standard Speed Alarm Position #009
10124	Alarm Position #010 Counter	—	1.0	0 – 32,767	Standard Speed Alarm Position #010
10125	Alarm Position #011 Counter	—	1.0	0 – 32,767	Standard Speed Alarm Position #011
10126	Alarm Position #012 Counter	—	1.0	0 – 32,767	Standard Speed Alarm Position #012
10127	Alarm Position #013 Counter	—	1.0	0 – 32,767	Standard Speed Alarm Position #013
10128	Alarm Position #014 Counter	—	1.0	0 – 32,767	Standard Speed Alarm Position #014
10129	Alarm Position #015 Counter	—	1.0	0 – 32,767	Standard Speed Alarm Position #015
10130	Alarm Position #016 Counter	—	1.0	0 – 32,767	Standard Speed Alarm Position #016
10131	Alarm Position #017 Counter	—	1.0	0 – 32,767	Standard Speed Alarm Position #017
10132	Alarm Position #018 Counter	—	1.0	0 – 32,767	Standard Speed Alarm Position #018
10133	Alarm Position #019 Counter	—	1.0	0 – 32,767	Standard Speed Alarm Position #019
10134	Alarm Position #020 Counter	—	1.0	0 – 32,767	Standard Speed Alarm Position #020
10135	Alarm Position #021 Counter	—	1.0	0 – 32,767	Standard Speed Alarm Position #021
10136	Alarm Position #022 Counter	—	1.0	0 – 32,767	Standard Speed Alarm Position #022
10137	Alarm Position #023 Counter	—	1.0	0 – 32,767	Standard Speed Alarm Position #023
10138	Alarm Position #024 Counter	—	1.0	0 – 32,767	Standard Speed Alarm Position #024
10139	Alarm Position #025 Counter	—	1.0	0 – 32,767	Standard Speed Alarm Position #025
10140	Alarm Position #026 Counter	—	1.0	0 – 32,767	Standard Speed Alarm Position #026
10141	Alarm Position #027 Counter	—	1.0	0 – 32,767	Standard Speed Alarm Position #027

Table A–6: Registers for Alarm Position Counters

Reg	Name	Scale	Units	Range	Notes
10142	Alarm Position #028 Counter	—	1.0	0 – 32,767	Standard Speed Alarm Position #028
10143	Alarm Position #029 Counter	—	1.0	0 – 32,767	Standard Speed Alarm Position #029
10144	Alarm Position #030 Counter	—	1.0	0 – 32,767	Standard Speed Alarm Position #030
10145	Alarm Position #031 Counter	—	1.0	0 – 32,767	Standard Speed Alarm Position #031
10146	Alarm Position #032 Counter	—	1.0	0 – 32,767	Standard Speed Alarm Position #032
10147	Alarm Position #033 Counter	—	1.0	0 – 32,767	Standard Speed Alarm Position #033
10148	Alarm Position #034 Counter	—	1.0	0 – 32,767	Standard Speed Alarm Position #034
10149	Alarm Position #035 Counter	—	1.0	0 – 32,767	Standard Speed Alarm Position #035
10150	Alarm Position #036 Counter	—	1.0	0 – 32,767	Standard Speed Alarm Position #036
10151	Alarm Position #037 Counter	—	1.0	0 – 32,767	Standard Speed Alarm Position #037
10152	Alarm Position #038 Counter	—	1.0	0 – 32,767	Standard Speed Alarm Position #038
10153	Alarm Position #039 Counter	—	1.0	0 – 32,767	Standard Speed Alarm Position #039
10154	Alarm Position #040 Counter	—	1.0	0 – 32,767	Standard Speed Alarm Position #040
10167	Alarm Position #053 Counter	—	1.0	0 – 32,767	Digital Alarm Position #001
10168	Alarm Position #054 Counter	—	1.0	0 – 32,767	Digital Alarm Position #002
10169	Alarm Position #055 Counter	—	1.0	0 – 32,767	Digital Alarm Position #003
10170	Alarm Position #056 Counter	—	1.0	0 – 32,767	Digital Alarm Position #004
10171	Alarm Position #057 Counter	—	1.0	0 – 32,767	Digital Alarm Position #005
10172	Alarm Position #058 Counter	—	1.0	0 – 32,767	Digital Alarm Position #006
10173	Alarm Position #059 Counter	—	1.0	0 – 32,767	Digital Alarm Position #007
10174	Alarm Position #060 Counter	—	1.0	0 – 32,767	Digital Alarm Position #008
10175	Alarm Position #061 Counter	—	1.0	0 – 32,767	Digital Alarm Position #009
10176	Alarm Position #062 Counter	—	1.0	0 – 32,767	Digital Alarm Position #010
10177	Alarm Position #063 Counter	—	1.0	0 – 32,767	Digital Alarm Position #011

Table A-6: Registers for Alarm Position Counters

Reg	Name	Scale	Units	Range	Notes
10178	Alarm Position #064 Counter	—	1.0	0 – 32,767	Digital Alarm Position #012
Alarms — Standard Speed					
10200	Alarm Position #001	—	See "Alarms — Template 1" on page 163	See "Alarms — Template 1" on page 163	Standard Speed Alarm Position #001 - See "Alarms — Template 1" on page 163
10220	Alarm Position #002	—	See "Alarms — Template 1" on page 163	See "Alarms — Template 1" on page 163	Standard Speed Alarm Position #002 - See "Alarms — Template 1" on page 163
10240	Alarm Position #003	—	See "Alarms — Template 1" on page 163	See "Alarms — Template 1" on page 163	Standard Speed Alarm Position #003 - See "Alarms — Template 1" on page 163
10260	Alarm Position #004	—	See "Alarms — Template 1" on page 163	See "Alarms — Template 1" on page 163	Standard Speed Alarm Position #004 - See "Alarms — Template 1" on page 163
10280	Alarm Position #005	—	See "Alarms — Template 1" on page 163	See "Alarms — Template 1" on page 163	Standard Speed Alarm Position #005 - See "Alarms — Template 1" on page 163
10300	Alarm Position #006	—	See "Alarms — Template 1" on page 163	See "Alarms — Template 1" on page 163	Standard Speed Alarm Position #006 - See "Alarms — Template 1" on page 163
10320	Alarm Position #007	—	See "Alarms — Template 1" on page 163	See "Alarms — Template 1" on page 163	Standard Speed Alarm Position #007 - See "Alarms — Template 1" on page 163
10340	Alarm Position #008	—	See "Alarms — Template 1" on page 163	See "Alarms — Template 1" on page 163	Standard Speed Alarm Position #008 - See "Alarms — Template 1" on page 163
10360	Alarm Position #009	—	See "Alarms — Template 1" on page 163	See "Alarms — Template 1" on page 163	Standard Speed Alarm Position #009 - See "Alarms — Template 1" on page 163
10380	Alarm Position #010	—	See "Alarms — Template 1" on page 163	See "Alarms — Template 1" on page 163	Standard Speed Alarm Position #010 - See "Alarms — Template 1" on page 163
10400	Alarm Position #011	—	See "Alarms — Template 1" on page 163	See "Alarms — Template 1" on page 163	Standard Speed Alarm Position #011 - See "Alarms — Template 1" on page 163
10420	Alarm Position #012	—	See "Alarms — Template 1" on page 163	See "Alarms — Template 1" on page 163	Standard Speed Alarm Position #012 - See "Alarms — Template 1" on page 163

Table A–6: Registers for Alarm Position Counters

Reg	Name	Scale	Units	Range	Notes
10440	Alarm Position #013	—	See "Alarms — Template 1" on page 163	See "Alarms — Template 1" on page 163	Standard Speed Alarm Position #013 - See "Alarms — Template 1" on page 163
10460	Alarm Position #014	—	See "Alarms — Template 1" on page 163	See "Alarms — Template 1" on page 163	Standard Speed Alarm Position #014 - See "Alarms — Template 1" on page 163
10480	Alarm Position #015	—	See "Alarms — Template 1" on page 163	See "Alarms — Template 1" on page 163	Standard Speed Alarm Position #015 - See "Alarms — Template 1" on page 163
10500	Alarm Position #016	—	See "Alarms — Template 1" on page 163	See "Alarms — Template 1" on page 163	Standard Speed Alarm Position #016 - See "Alarms — Template 1" on page 163
10520	Alarm Position #017	—	See "Alarms — Template 1" on page 163	See "Alarms — Template 1" on page 163	Standard Speed Alarm Position #017 - See "Alarms — Template 1" on page 163
10540	Alarm Position #018	—	See "Alarms — Template 1" on page 163	See "Alarms — Template 1" on page 163	Standard Speed Alarm Position #018 - See "Alarms — Template 1" on page 163
10560	Alarm Position #019	—	See "Alarms — Template 1" on page 163	See "Alarms — Template 1" on page 163	Standard Speed Alarm Position #019 - See "Alarms — Template 1" on page 163
10580	Alarm Position #020	—	See "Alarms — Template 1" on page 163	See "Alarms — Template 1" on page 163	Standard Speed Alarm Position #020 - See "Alarms — Template 1" on page 163
10600	Alarm Position #021	—	See "Alarms — Template 1" on page 163	See "Alarms — Template 1" on page 163	Standard Speed Alarm Position #021 - See "Alarms — Template 1" on page 163
10620	Alarm Position #022	—	See "Alarms — Template 1" on page 163	See "Alarms — Template 1" on page 163	Standard Speed Alarm Position #022 - See "Alarms — Template 1" on page 163
10640	Alarm Position #023	—	See "Alarms — Template 1" on page 163	See "Alarms — Template 1" on page 163	Standard Speed Alarm Position #023 - See "Alarms — Template 1" on page 163
10660	Alarm Position #024	—	See "Alarms — Template 1" on page 163	See "Alarms — Template 1" on page 163	Standard Speed Alarm Position #024 - See "Alarms — Template 1" on page 163
10680	Alarm Position #025	—	See "Alarms — Template 1" on page 163	See "Alarms — Template 1" on page 163	Standard Speed Alarm Position #025 - See "Alarms — Template 1" on page 163

Table A-6: Registers for Alarm Position Counters

Reg	Name	Scale	Units	Range	Notes
10700	Alarm Position #026	—	See "Alarms — Template 1" on page 163	See "Alarms — Template 1" on page 163	Standard Speed Alarm Position #026 - See "Alarms — Template 1" on page 163
10720	Alarm Position #027	—	See "Alarms — Template 1" on page 163	See "Alarms — Template 1" on page 163	Standard Speed Alarm Position #027 - See "Alarms — Template 1" on page 163
10740	Alarm Position #028	—	See "Alarms — Template 1" on page 163	See "Alarms — Template 1" on page 163	Standard Speed Alarm Position #028 - See "Alarms — Template 1" on page 163
10760	Alarm Position #029	—	See "Alarms — Template 1" on page 163	See "Alarms — Template 1" on page 163	Standard Speed Alarm Position #029 - See "Alarms — Template 1" on page 163
10780	Alarm Position #030	—	See "Alarms — Template 1" on page 163	See "Alarms — Template 1" on page 163	Standard Speed Alarm Position #030 - See "Alarms — Template 1" on page 163
10800	Alarm Position #031	—	See "Alarms — Template 1" on page 163	See "Alarms — Template 1" on page 163	Standard Speed Alarm Position #031 - See "Alarms — Template 1" on page 163
10820	Alarm Position #032	—	See "Alarms — Template 1" on page 163	See "Alarms — Template 1" on page 163	Standard Speed Alarm Position #032 - See "Alarms — Template 1" on page 163
10840	Alarm Position #033	—	See "Alarms — Template 1" on page 163	See "Alarms — Template 1" on page 163	Standard Speed Alarm Position #033 - See "Alarms — Template 1" on page 163
10860	Alarm Position #034	—	See "Alarms — Template 1" on page 163	See "Alarms — Template 1" on page 163	Standard Speed Alarm Position #034 - See "Alarms — Template 1" on page 163
10880	Alarm Position #035	—	See "Alarms — Template 1" on page 163	See "Alarms — Template 1" on page 163	Standard Speed Alarm Position #035 - See "Alarms — Template 1" on page 163
10900	Alarm Position #036	—	See "Alarms — Template 1" on page 163	See "Alarms — Template 1" on page 163	Standard Speed Alarm Position #036 - See "Alarms — Template 1" on page 163
10920	Alarm Position #037	—	See "Alarms — Template 1" on page 163	See "Alarms — Template 1" on page 163	Standard Speed Alarm Position #037 - See "Alarms — Template 1" on page 163
10940	Alarm Position #038	—	See "Alarms — Template 1" on page 163	See "Alarms — Template 1" on page 163	Standard Speed Alarm Position #038 - See "Alarms — Template 1" on page 163

Table A–6: Registers for Alarm Position Counters

Reg	Name	Scale	Units	Range	Notes
10960	Alarm Position #039	—	See "Alarms — Template 1" on page 163	See "Alarms — Template 1" on page 163	Standard Speed Alarm Position #039 - See "Alarms — Template 1" on page 163
10980	Alarm Position #040	—	See "Alarms — Template 1" on page 163	See "Alarms — Template 1" on page 163	Standard Speed Alarm Position #040 - See "Alarms — Template 1" on page 163
Alarms — Digital					
11240	Alarm Position #053	—	See "Alarms — Template 1" on page 163	See "Alarms — Template 1" on page 163	Digital Alarm Position #001 - See "Alarms — Template 1" on page 163
11260	Alarm Position #054	—	See "Alarms — Template 1" on page 163	See "Alarms — Template 1" on page 163	Digital Alarm Position #002 - See "Alarms — Template 1" on page 163
11280	Alarm Position #055	—	See "Alarms — Template 1" on page 163	See "Alarms — Template 1" on page 163	Digital Alarm Position #003 - See "Alarms — Template 1" on page 163
11300	Alarm Position #056	—	See "Alarms — Template 1" on page 163	See "Alarms — Template 1" on page 163	Digital Alarm Position #004 - See "Alarms — Template 1" on page 163
11320	Alarm Position #057	—	See "Alarms — Template 1" on page 163	See "Alarms — Template 1" on page 163	Digital Alarm Position #005 - See "Alarms — Template 1" on page 163
11340	Alarm Position #058	—	See "Alarms — Template 1" on page 163	See "Alarms — Template 1" on page 163	Digital Alarm Position #006 - See "Alarms — Template 1" on page 163
11360	Alarm Position #059	—	See "Alarms — Template 1" on page 163	See "Alarms — Template 1" on page 163	Digital Alarm Position #007 - See "Alarms — Template 1" on page 163
11380	Alarm Position #060	—	See "Alarms — Template 1" on page 163	See "Alarms — Template 1" on page 163	Digital Alarm Position #008 - See "Alarms — Template 1" on page 163
11400	Alarm Position #061	—	See "Alarms — Template 1" on page 163	See "Alarms — Template 1" on page 163	Digital Alarm Position #009 - See "Alarms — Template 1" on page 163
11420	Alarm Position #062	—	See "Alarms — Template 1" on page 163	See "Alarms — Template 1" on page 163	Digital Alarm Position #010 - See "Alarms — Template 1" on page 163
11440	Alarm Position #063	—	See "Alarms — Template 1" on page 163	See "Alarms — Template 1" on page 163	Digital Alarm Position #011 - See "Alarms — Template 1" on page 163

Table A-6: Registers for Alarm Position Counters

Reg	Name	Scale	Units	Range	Notes
11460	Alarm Position #064	—	See "Alarms — Template 1" on page 163	See "Alarms — Template 1" on page 163	Digital Alarm Position #012 - See "Alarms — Template 1" on page 163
Alarms — Template 1					
Base	Unique Identifier	—	—	0 – 0xFFFFFFFF	Bits 00 – 07 = Level (0 – 9) Bits 08 – 15 = Alarm Type Bits 16 – 31 = Test Register For Unary Alarms, Test Register is: 1 = End of Incremental Energy Interval 2 = End of Power Demand Interval 3 = End of 1s Meter Update Cycle 4 = Reserved 5 = Power up/ Reset
Base +2	Enable/Disable, Priority	—	—	MSB: 0 – FF LSB: 0 – 3	MSB: 0x00 = Disabled (Default) 0xFF = Enabled LSB: Specifies the priority level 0 – 3
Base +3	Label	—	—	ASCII	16 Characters
Base +11	Pickup Value	A-F	Units/Scale	0 – 32,767	Does not apply to digital or unary alarms
Base +12	Pickup Delay	—	1s Cycle	0 – 32,767 0 – 999 0 – 999	Standard Speed Alarms Does not apply to digital or unary alarms.
Base +13	Dropout Value	A-F —	Units/Scale	0 – 32,767	Does not apply to digital or unary alarms.
Base +14	Dropout Delay	—	1s Cycle	0 – 32,767 0 – 999 0 – 999	Standard Speed Alarms Does not apply to digital or unary alarms.
Base +15	Reserved	—	—	—	Reserved for future development
Base +16	Datalog Specifier	—	—	0 – 0xFFFFFFFF	Bit 00 = Datalog #1 (PM810 with PM810LOG)
Alarms — Template 2					
Base	Unique Identifier	—	—	0 – 0xFFFFFFFF	Bits 00 – 07 = Level (0 – 9) Bits 08 – 15 = Alarm Type Bits 16 – 31 = Test Register
Base +2	Enable/Disable, Priority	—	—	MSB: 0 – FF LSB: 0 – 3	MSB: 0x00 = Disable; 0xFF = Enable LSB: Specifies the priority level 0 – 3
Base +3	Label	—	—	ASCII	16 Characters
Base +11	Alarm test list	—	—	0 – 74	Alarm test list (position # in the normal alarm list)

Table A–7: Abbreviated Floating-Point Register List

Reg	Name	Units	Notes
1s Metering – Current			
11700	Current, Phase A	Amps	RMS
11702	Current, Phase B	Amps	RMS
11704	Current, Phase C	Amps	RMS
11706	Current, Neutral	Amps	RMS 4-wire system only
11708	Current, Ground	Amps	RMS 4-wire system only
11710	Current, 3-Phase Average	Amps	Calculated mean of Phases A, B & C
1s Metering – Voltage			
11712	Voltage, A-B	Volts	RMS Voltage measured between A & B
11714	Voltage, B-C	Volts	RMS Voltage measured between B & C
11716	Voltage, C-A	Volts	RMS Voltage measured between C & A
11718	Voltage, L-L Average	Volts	RMS 3 Phase Average L-L Voltage
11720	Voltage, A-N	Volts	RMS Voltage measured between A & N 4-wire system only
11722	Voltage, B-N	Volts	RMS Voltage measured between B & N 4-wire system only
11724	Voltage, C-N	Volts	RMS Voltage measured between C & N 4-wire system only
11726	Voltage, N-G	Volts	RMS Voltage measured between N & G 4-wire system with 4 element metering only
11728	Voltage, L-N Average	Volts	RMS 3-Phase Average L-N Voltage
1s Metering – Power			
11730	Real Power, Phase A	W	Real Power (PA) 4-wire system only
11732	Real Power, Phase B	W	Real Power (PB) 4-wire system only
11734	Real Power, Phase C	W	Real Power (PC) 4-wire system only
11736	Real Power, Total	W	4-wire system = PA+PB+PC 3-wire system = 3-Phase real power
11738	Reactive Power, Phase A	VA _r	Reactive Power (QA) 4-wire system only
11740	Reactive Power, Phase B	VA _r	Reactive Power (QB) 4-wire system only
11742	Reactive Power, Phase C	VA _r	Reactive Power (QC) 4-wire system only
11744	Reactive Power, Total	VA _r	4-wire system = QA+QB+QC 3 wire system = 3-Phase reactive power
11746	Apparent Power, Phase A	VA	Apparent Power (SA) 4-wire system only
11748	Apparent Power, Phase B	VA	Apparent Power (SB) 4-wire system only
11750	Apparent Power, Phase C	VA	Apparent Power (SC) 4-wire system only

Table A-7: Abbreviated Floating-Point Register List

Reg	Name	Units	Notes
11752	Apparent Power, Total	VA	4-wire system = SA+SB+SC 3-wire system = 3-Phase apparent power
1s Metering – Power Factor			
11754	True Power Factor, Phase A		Derived using the complete harmonic content of real and apparent power. 4-wire system only
11756	True Power Factor, Phase B		Derived using the complete harmonic content of real and apparent power. 4-wire system only
11758	True Power Factor, Phase C		Derived using the complete harmonic content of real and apparent power. 4-wire system only
11760	True Power Factor, Total		Derived using the complete harmonic content of real and apparent power
1s Metering – Frequency			
11762	Frequency	Hz	Frequency of circuits being monitored. If the frequency is out of range, the register will be -32,768.
Energy			
11800	Energy, Real In	WH	3-Phase total real energy into the load
11802	Energy, Reactive In	VArH	3-Phase total reactive energy into the load
11804	Energy, Real Out	WH	3-Phase total real energy out of the load
11806	Energy, Reactive Out	VArH	3-Phase total reactive energy out of the load
11808	Energy, Real Total (signed/absolute)	WH	Total Real Energy In, Out or In + Out
11810	Energy, Reactive Total (signed/absolute)	VArH	Total Reactive Energy In, Out or In + Out
11812	Energy, Apparent	VAH	3-Phase total apparent energy
11814	Energy, Conditional Real In	WH	3-Phase total accumulated conditional real energy into the load
11816	Energy, Conditional Reactive In	VArH	3-Phase total accumulated conditional reactive energy into the load
11818	Energy, Conditional Real Out	WH	3-Phase total accumulated conditional real energy out of the load
11820	Energy, Conditional Reactive Out	VArH	3-Phase total accumulated conditional reactive energy out of the load
11822	Energy, Conditional Apparent	VAH	3-Phase total accumulated conditional apparent energy
11824	Energy, Incremental Real In, Last Complete Interval	WH	3-Phase total accumulated incremental real energy into the load
11826	Energy, Incremental Reactive In, Last Complete Interval	VArH	3-Phase total accumulated incremental reactive energy into the load
11828	Energy, Incremental Real Out, Last Complete Interval	WH	3-Phase total accumulated incremental real energy out of the load
11830	Energy, Incremental Reactive Out, Last Complete Interval	VArH	3-Phase total accumulated incremental reactive energy out of the load
11832	Energy, Incremental Apparent, Last Complete Interval	VAH	3-Phase total accumulated incremental apparent energy

Table A-7: Abbreviated Floating-Point Register List

Reg	Name	Units	Notes
11836	Energy, Incremental Real In, Present Interval	WH	3-Phase total accumulated incremental real energy into the load
11838	Energy, Incremental Reactive In, Present Interval	VARH	3-Phase total accumulated incremental reactive energy into the load
11840	Energy, Incremental Real Out, Present Interval	WH	3-Phase total accumulated incremental real energy out of the load
11842	Energy, Incremental Reactive Out, Present Interval	VARH	3-Phase total accumulated incremental reactive energy out of the load
11844	Energy, Incremental Apparent, Present Interval	VAH	3-Phase total accumulated incremental apparent energy
11846	Energy, Reactive, Quadrant 1	VARH	3-Phase total accumulated incremental reactive energy – quadrant 1
11848	Energy, Reactive, Quadrant 2	VARH	3-Phase total accumulated incremental reactive energy – quadrant 2
11850	Energy, Reactive, Quadrant 3	VARH	3-Phase total accumulated incremental reactive energy – quadrant 3
11852	Energy, Reactive, Quadrant 4	VARH	3-Phase total accumulated incremental reactive energy – quadrant 4
11854	Cumulative Usage Input Channel #1	(2)	The user must identify the units to be used in the accumulation.
11856	Cumulative Usage Input Channel #2	(2)	The user must identify the units to be used in the accumulation.
11858	Cumulative Usage Input Channel #3	(2)	The user must identify the units to be used in the accumulation.
11860	Cumulative Usage Input Channel #4	(2)	The user must identify the units to be used in the accumulation.
11862	Cumulative Usage Input Channel #5	(2)	The user must identify the units to be used in the accumulation.
11864	Energy, Real 3-Phase Total Usage Today	WH	
11866	Energy, Real 3-Phase Total Usage Yesterday	WH	
11868	Energy, Real 3-Phase Total Usage This Week	WH	
11870	Energy, Real 3-Phase Total Usage Last Week	WH	
11872	Energy, Real 3-Phase Total Usage This Month	WH	
11874	Energy, Real 3-Phase Total Usage Last Month	WH	
11876	Energy, Apparent 3-Phase Total Usage Today	WH	
11878	Energy, Apparent 3-Phase Total Usage Yesterday	WH	
11880	Energy, Apparent 3-Phase Total Usage This Week	VAH	

Table A-7: Abbreviated Floating-Point Register List

Reg	Name	Units	Notes
11882	Energy, Apparent 3-Phase Total Usage Last Week	VAH	
11884	Energy, Apparent 3-Phase Total Usage This Month	VAH	
11886	Energy, Apparent 3-Phase Total Usage Last Month	VAH	
11888	Energy, Real 3-Phase Total Usage – First Shift – Today	VAH	
11890	Energy, Real 3-Phase Total Usage – Second Shift – Today	VAH	
11892	Energy, Real 3-Phase Total Usage – Third Shift – Today	VAH	
11894	Energy, Real 3-Phase Total Usage – First Shift – Yesterday	VAH	
11896	Energy, Real 3-Phase Total Usage – Second Shift – Yesterday	WH	
11898	Energy, Real 3-Phase Total Usage – Third Shift – Yesterday	WH	
11900	Energy, Real 3-Phase Total Usage – First Shift – This Week	WH	
11902	Energy, Real 3-Phase Total Usage – Second Shift – This Week	WH	
11904	Energy, Real 3-Phase Total Usage – Third Shift – This Week	WH	
11906	Energy, Real 3-Phase Total Usage – First Shift – Last Week	WH	
11908	Energy, Real 3-Phase Total Usage – Second Shift – Last Week	WH	
11910	Energy, Real 3-Phase Total Usage – Third Shift – Last Week	WH	
11912	Energy, Real 3-Phase Total Usage – First Shift – This Month	WH	
11914	Energy, Real 3-Phase Total Usage – Second Shift – This Month	WH	
11916	Energy, Real 3-Phase Total Usage – Third Shift – This Month	WH	

Table A-7: Abbreviated Floating-Point Register List

Reg	Name	Units	Notes
11918	Energy, Real 3-Phase Total Usage – First Shift – Last Month	WH	
11920	Energy, Real 3-Phase Total Usage – Second Shift – Last Month	WH	
11922	Energy, Real 3-Phase Total Usage – Third Shift – Last Month	WH	
11924	Energy, Apparent 3-Phase Total Usage – First Shift – Today	WH	
11926	Energy, Apparent 3-Phase Total Usage – Second Shift – Today	WH	
11928	Energy, Apparent 3-Phase Total Usage – Third Shift – Today	WH	
11930	Energy, Apparent 3-Phase Total Usage – First Shift – Yesterday	WH	
11932	Energy, Apparent 3-Phase Total Usage – Second Shift – Yesterday	VAH	
11934	Energy, Apparent 3-Phase Total Usage – Third Shift – Yesterday	VAH	
11936	Energy, Apparent 3-Phase Total Usage – First Shift – This Week	VAH	
11938	Energy, Apparent 3-Phase Total Usage – Second Shift – This Week	VAH	
11940	Energy, Apparent 3-Phase Total Usage – Third Shift – This Week	VAH	
11942	Energy, Apparent 3-Phase Total Usage – First Shift – Last Week	VAH	
11944	Energy, Apparent 3-Phase Total Usage – Second Shift – Last Week	VAH	
11946	Energy, Apparent 3-Phase Total Usage – Third Shift – Last Week	VAH	

Table A-7: Abbreviated Floating-Point Register List

Reg	Name	Units	Notes
11948	Energy, Apparent 3-Phase Total Usage – First Shift – This Month	VAH	
11950	Energy, Apparent 3-Phase Total Usage – Second Shift – This Month	VAH	
11952	Energy, Apparent 3-Phase Total Usage – Third Shift – This Month	VAH	
11954	Energy, Apparent 3-Phase Total Usage – First Shift – Last Month	VAH	
11956	Energy, Apparent 3-Phase Total Usage – Second Shift – Last Month	VAH	
11958	Energy, Apparent 3-Phase Total Usage – Third Shift – Last Month	VAH	
11960	THD/thd Current, Phase A	-	Total Harmonic Distortion, Phase A Current See register 3227 for THD/ thd definition
11962	THD/thd Current, Phase B	-	Total Harmonic Distortion, Phase B Current See register 3227 for THD/ thd definition
11964	THD/thd Current, Phase C	-	Total Harmonic Distortion, Phase C Current See register 3227 for THD/ thd definition
11966	THD/thd Current, Phase N	-	Total Harmonic Distortion, Phase N Current (4-wire systems and system type and 12 only) See register 3227 for THD/ thd definition
11968	THD/thd Voltage, Phase A-N	-	Total Harmonic Distortion Phase A-N (4-wire systems and system types 10 and 12) See register 3227 for THD/ thd definition
11970	THD/thd Voltage, Phase B-N	-	Total Harmonic Distortion Phase B-N (4-wire systems and system type 12 only) See register 3227 for THD/ thd definition
11972	THD/thd Voltage, Phase C-N	-	Total Harmonic Distortion Phase C-N (4-wire system only) See register 3227 for THD/ thd definition
11974	THD/thd Voltage, Phase A-B	-	Total Harmonic Distortion Phase A-B See register 3227 for THD/ thd definition
11976	THD/thd Voltage, Phase B-C	-	Total Harmonic Distortion Phase B-C See register 3227 for THD/ thd definition
11978	THD/thd Voltage, Phase C-A	-	Total Harmonic Distortion Phase C-A See register 3227 for THD/ thd definition

Table A–8: Spectral Components (PM810 with PM810LOG)

Reg	Name	Scale	Units	Range	Notes
Spectral Components					
Spectral Components — Harmonic Magnitudes and Angles					
13200	Harmonic Magnitudes and Angles, Voltage A-B	—	See "Spectral Components — Data Template (PM810 with PM810LOG)" on page 171	See "Spectral Components — Data Template (PM810 with PM810LOG)" on page 171	See "Spectral Components — Data Template (PM810 with PM810LOG)" on page 171
13328	Harmonic Magnitudes and Angles, Voltage B-C	—	See "Spectral Components — Data Template (PM810 with PM810LOG)" on page 171	See "Spectral Components — Data Template (PM810 with PM810LOG)" on page 171	See "Spectral Components — Data Template (PM810 with PM810LOG)" on page 171
13456	Harmonic Magnitudes and Angles, Voltage C-A	—	See "Spectral Components — Data Template (PM810 with PM810LOG)" on page 171	See "Spectral Components — Data Template (PM810 with PM810LOG)" on page 171	See "Spectral Components — Data Template (PM810 with PM810LOG)" on page 171
13584	Harmonic Magnitudes and Angles, Voltage A-N	—	See "Spectral Components — Data Template (PM810 with PM810LOG)" on page 171	See "Spectral Components — Data Template (PM810 with PM810LOG)" on page 171	See "Spectral Components — Data Template (PM810 with PM810LOG)" on page 171
13712	Harmonic Magnitudes and Angles, Voltage B-N	—	See "Spectral Components — Data Template (PM810 with PM810LOG)" on page 171	See "Spectral Components — Data Template (PM810 with PM810LOG)" on page 171	See "Spectral Components — Data Template (PM810 with PM810LOG)" on page 171
13840	Harmonic Magnitudes and Angles, Voltage C-N	—	See "Spectral Components — Data Template (PM810 with PM810LOG)" on page 171	See "Spectral Components — Data Template (PM810 with PM810LOG)" on page 171	See "Spectral Components — Data Template (PM810 with PM810LOG)" on page 171
13968	Harmonic Magnitudes and Angles, Voltage N-G	—	See "Spectral Components — Data Template (PM810 with PM810LOG)" on page 171	See "Spectral Components — Data Template (PM810 with PM810LOG)" on page 171	See "Spectral Components — Data Template (PM810 with PM810LOG)" on page 171
14096	Harmonic Magnitudes and Angles, Current, Phase A	—	See "Spectral Components — Data Template (PM810 with PM810LOG)" on page 171	See "Spectral Components — Data Template (PM810 with PM810LOG)" on page 171	See "Spectral Components — Data Template (PM810 with PM810LOG)" on page 171

Table A–8: Spectral Components (PM810 with PM810LOG)

Reg	Name	Scale	Units	Range	Notes
14224	Harmonic Magnitudes and Angles, Current, Phase B	—	See "Spectral Components — Data Template (PM810 with PM810LOG)" on page 171	See "Spectral Components — Data Template (PM810 with PM810LOG)" on page 171	See "Spectral Components — Data Template (PM810 with PM810LOG)" on page 171
14352	Harmonic Magnitudes and Angles, Current, Phase C	—	See "Spectral Components — Data Template (PM810 with PM810LOG)" on page 171	See "Spectral Components — Data Template (PM810 with PM810LOG)" on page 171	See "Spectral Components — Data Template (PM810 with PM810LOG)" on page 171
14480	Harmonic Magnitudes and Angles, Current, Neutral	—	See "Spectral Components — Data Template (PM810 with PM810LOG)" on page 171	See "Spectral Components — Data Template (PM810 with PM810LOG)" on page 171	See "Spectral Components — Data Template (PM810 with PM810LOG)" on page 171
Spectral Components — Data Template (PM810 with PM810LOG)					
Base	Reference Magnitude	—	Volts/Scale Amps/Scale	0 – 32,767 (-32,768 if N/A)	Magnitude of fundamental or overall RMS value which harmonic percentages are based. Format selection is based on the value in register 3241 or 3242. A selection of 2 (RMS) will cause a value of -32768 to be entered.
Base +1	Scale Factor	—	1.0	-3 – 3 (-32,768 if N/A)	Power of 10
Base +2	H1 Magnitude	% D,E A,B	.01 Volts/Scale Amps/Scale	0 – 10000 0 – 32,767 0 – 32,767	Magnitude of harmonic expressed as a percentage of the reference value, or as an absolute value.
Base +3	H1 Angle	—	0.1 °	0 – 3,599 (-32,678 if N/A)	Angle of 1st harmonic referenced to fundamental Voltage A-N (4-wire) or Voltage A-B (3-wire).
Base +4	H2 Magnitude	% D,E A,B	.01 Volts/Scale Amps/Scale	0 – 10000 0 – 32,767 0 – 32,767	Magnitude of harmonic expressed as a percentage of the reference value, or as an absolute value.
Base +5	H2 Angle	—	0.1 °	0 – 3,599 (-32,678 if N/A)	Angle of 2nd harmonic referenced to fundamental Voltage A-N (4-wire) or Voltage A-B (3-wire).
Base +6	H3 Magnitude	% D,E A,B	.01 Volts/Scale Amps/Scale	0 – 10000 0 – 32,767 0 – 32,767	Magnitude of harmonic expressed as a percentage of the reference value, or as an absolute value.
Base +7	H3 Angle	—	0.1 °	0 – 3,599 (-32,678 if N/A)	Angle of 3rd harmonic referenced to fundamental Voltage A-N (4-wire) or Voltage A-B (3-wire).
Base +8	H4 Magnitude	% D,E A,B	.01 Volts/Scale Amps/Scale	0 – 10000 0 – 32,767 0 – 32,767	Magnitude of harmonic expressed as a percentage of the reference value, or as an absolute value.

Table A–8: Spectral Components (PM810 with PM810LOG)

Reg	Name	Scale	Units	Range	Notes
Base +9	H4 Angle	—	0.1 °	0 – 3,599 (-32,678 if N/A)	Angle of 4th harmonic referenced to fundamental Voltage A-N (4-wire) or Voltage A-B (3-wire).
Base +10	H5 Magnitude	% D,E A,B	.01 Volts/Scale Amps/Scale	0 – 10000 0 – 32,767 0 – 32,767	Magnitude of harmonic expressed as a percentage of the reference value, or as an absolute value.
Base +11	H5 Angle	—	0.1 °	0 – 3,599 (-32,678 if N/A)	Angle of 5th harmonic referenced to fundamental Voltage A-N (4-wire) or Voltage A-B (3-wire).
Base +12	H6 Magnitude	% D,E A,B	.01 Volts/Scale Amps/Scale	0 – 10000 0 – 32,767 0 – 32,767	Magnitude of harmonic expressed as a percentage of the reference value, or as an absolute value.
Base +13	H6 Angle	—	0.1 °	0 – 3,599 (-32,678 if N/A)	Angle of 6th harmonic referenced to fundamental Voltage A-N (4-wire) or Voltage A-B (3-wire).
Base +14	H7 Magnitude	% D,E A,B	.01 Volts/Scale Amps/Scale	0 – 10000 0 – 32,767 0 – 32,767	Magnitude of harmonic expressed as a percentage of the reference value, or as an absolute value.
Base +15	H7 Angle	—	0.1 °	0 – 3,599 (-32,678 if N/A)	Angle of 7th harmonic referenced to fundamental Voltage A-N (4-wire) or Voltage A-B (3-wire).
Base +16	H8 Magnitude	% D,E A,B	.01 Volts/Scale Amps/Scale	0 – 10000 0 – 32,767 0 – 32,767	Magnitude of harmonic expressed as a percentage of the reference value, or as an absolute value.
Base +17	H8 Angle	—	0.1 °	0 – 3,599 (-32,678 if N/A)	Angle of 8th harmonic referenced to fundamental Voltage A-N (4-wire) or Voltage A-B (3-wire).
Base +18	H9 Magnitude	% D,E A,B	.01 Volts/Scale Amps/Scale	0 – 10000 0 – 32,767 0 – 32,767	Magnitude of harmonic expressed as a percentage of the reference value, or as an absolute value.
Base +19	H9 Angle	—	0.1 °	0 – 3,599 (-32,678 if N/A)	Angle of 9th harmonic referenced to fundamental Voltage A-N (4-wire) or Voltage A-B (3-wire).
Base +20	H10 Magnitude	% D,E A,B	.01 Volts/Scale Amps/Scale	0 – 10000 0 – 32,767 0 – 32,767	Magnitude of harmonic expressed as a percentage of the reference value, or as an absolute value.
Base +21	H10 Angle	—	0.1 °	0 – 3,599 (-32,678 if N/A)	Angle of 10th harmonic referenced to fundamental Voltage A-N (4-wire) or Voltage A-B (3-wire).
Base +22	H11 Magnitude	% D,E A,B	.01 Volts/Scale Amps/Scale	0 – 10000 0 – 32,767 0 – 32,767	Magnitude of harmonic expressed as a percentage of the reference value, or as an absolute value.
Base +23	H11 Angle	—	0.1 °	0 – 3,599 (-32,678 if N/A)	Angle of 11th harmonic referenced to fundamental Voltage A-N (4-wire) or Voltage A-B (3-wire).

Table A-8: Spectral Components (PM810 with PM810LOG)

Reg	Name	Scale	Units	Range	Notes
Base + 24	H12 Magnitude	% D,E A,B	.01 Volts/Scale Amps/Scale	0 – 10000 0 – 32,767 0 – 32,767	Magnitude of harmonic expressed as a percentage of the reference value, or as an absolute value.
Base + 25	H12 Angle	—	0.1 °	0 – 3,599 (-32,678 if N/A)	Angle of 12th harmonic referenced to fundamental Voltage A-N (4-wire) or Voltage A-B (3-wire).
Base + 26	H13 Magnitude	% D,E A,B	.01 Volts/Scale Amps/Scale	0 – 10000 0 – 32,767 0 – 32,767	Magnitude of harmonic expressed as a percentage of the reference value, or as an absolute value.
Base + 27	H13 Angle	—	0.1 °	0 – 3,599 (-32,678 if N/A)	Angle of 13th harmonic referenced to fundamental Voltage A-N (4-wire) or Voltage A-B (3-wire).
Base + 28	H14 Magnitude	% D,E A,B	.01 Volts/Scale Amps/Scale	0 – 10000 0 – 32,767 0 – 32,767	Magnitude of harmonic expressed as a percentage of the reference value, or as an absolute value.
Base + 29	H14 Angle	—	0.1 °	0 – 3,599 (-32,678 if N/A)	Angle of 14th harmonic referenced to fundamental Voltage A-N (4-wire) or Voltage A-B (3-wire).
Base + 30	H15 Magnitude	% D,E A,B	.01 Volts/Scale Amps/Scale	0 – 10000 0 – 32,767 0 – 32,767	Magnitude of harmonic expressed as a percentage of the reference value, or as an absolute value.
Base + 31	H15 Angle	—	0.1 °	0 – 3,599 (-32,678 if N/A)	Angle of 15th harmonic referenced to fundamental Voltage A-N (4-wire) or Voltage A-B (3-wire).
Base + 32	H16 Magnitude	% D,E A,B	.01 Volts/Scale Amps/Scale	0 – 10000 0 – 32,767 0 – 32,767	Magnitude of harmonic expressed as a percentage of the reference value, or as an absolute value.
Base + 33	H16 Angle	—	0.1 °	0 – 3,599 (-32,678 if N/A)	Angle of 16th harmonic referenced to fundamental Voltage A-N (4-wire) or Voltage A-B (3-wire).
Base + 34	H17 Magnitude	% D,E A,B	.01 Volts/Scale Amps/Scale	0 – 10000 0 – 32,767 0 – 32,767	Magnitude of harmonic expressed as a percentage of the reference value, or as an absolute value.
Base + 35	H17 Angle	—	0.1 °	0 – 3,599 (-32,678 if N/A)	Angle of 17th harmonic referenced to fundamental Voltage A-N (4-wire) or Voltage A-B (3-wire).
Base + 36	H18 Magnitude	% D,E A,B	.01 Volts/Scale Amps/Scale	0 – 10000 0 – 32,767 0 – 32,767	Magnitude of harmonic expressed as a percentage of the reference value, or as an absolute value.
Base + 37	H18 Angle	—	0.1 °	0 – 3,599 (-32,678 if N/A)	Angle of 18th harmonic referenced to fundamental Voltage A-N (4-wire) or Voltage A-B (3-wire).
Base + 38	H19 Magnitude	% D,E A,B	.01 Volts/Scale Amps/Scale	0 – 10000 0 – 32,767 0 – 32,767	Magnitude of harmonic expressed as a percentage of the reference value, or as an absolute value.

Table A–8: Spectral Components (PM810 with PM810LOG)

Reg	Name	Scale	Units	Range	Notes
Base + 39	H19 Angle	—	0.1 °	0 – 3,599 (-32,678 if N/A)	Angle of 19th harmonic referenced to fundamental Voltage A-N (4-wire) or Voltage A-B (3-wire).
Base + 40	H20 Magnitude	% D,E A,B	.01 Volts/Scale Amps/Scale	0 – 10000 0 – 32,767 0 – 32,767	Magnitude of harmonic expressed as a percentage of the reference value, or as an absolute value.
Base + 41	H20 Angle	—	0.1 °	0 – 3,599 (-32,678 if N/A)	Angle of 20th harmonic referenced to fundamental Voltage A-N (4-wire) or Voltage A-B (3-wire).
Base + 42	H21 Magnitude	% D,E A,B	.01 Volts/Scale Amps/Scale	0 – 10000 0 – 32,767 0 – 32,767	Magnitude of harmonic expressed as a percentage of the reference value, or as an absolute value.
Base + 43	H21 Angle	—	0.1 °	0 – 3,599 (-32,678 if N/A)	Angle of 21st harmonic referenced to fundamental Voltage A-N (4-wire) or Voltage A-B (3-wire).
Base + 44	H22 Magnitude	% D,E A,B	.01 Volts/Scale Amps/Scale	0 – 10000 0 – 32,767 0 – 32,767	Magnitude of harmonic expressed as a percentage of the reference value, or as an absolute value.
Base + 45	H22 Angle	—	0.1 °	0 – 3,599 (-32,678 if N/A)	Angle of 22nd harmonic referenced to fundamental Voltage A-N (4-wire) or Voltage A-B (3-wire).
Base + 46	H23 Magnitude	% D,E A,B	.01 Volts/Scale Amps/Scale	0 – 10000 0 – 32,767 0 – 32,767	Magnitude of harmonic expressed as a percentage of the reference value, or as an absolute value.
Base + 47	H23 Angle	—	0.1 °	0 – 3,599 (-32,678 if N/A)	Angle of 23rd harmonic referenced to fundamental Voltage A-N (4-wire) or Voltage A-B (3-wire).
Base + 48	H24 Magnitude	% D,E A,B	.01 Volts/Scale Amps/Scale	0 – 10000 0 – 32,767 0 – 32,767	Magnitude of harmonic expressed as a percentage of the reference value, or as an absolute value.
Base + 49	H24 Angle	—	0.1 °	0 – 3,599 (-32,678 if N/A)	Angle of 24th harmonic referenced to fundamental Voltage A-N (4-wire) or Voltage A-B (3-wire).
Base + 50	H25 Magnitude	% D,E A,B	.01 Volts/Scale Amps/Scale	0 – 10000 0 – 32,767 0 – 32,767	Magnitude of harmonic expressed as a percentage of the reference value, or as an absolute value.
Base + 51	H25 Angle	—	0.1 °	0 – 3,599 (-32,678 if N/A)	Angle of 25th harmonic referenced to fundamental Voltage A-N (4-wire) or Voltage A-B (3-wire).
Base + 52	H26 Magnitude	% D,E A,B	.01 Volts/Scale Amps/Scale	0 – 10000 0 – 32,767 0 – 32,767	Magnitude of harmonic expressed as a percentage of the reference value, or as an absolute value.
Base + 53	H26 Angle	—	0.1 °	0 – 3,599 (-32,678 if N/A)	Angle of 26th harmonic referenced to fundamental Voltage A-N (4-wire) or Voltage A-B (3-wire).

Table A–8: Spectral Components (PM810 with PM810LOG)

Reg	Name	Scale	Units	Range	Notes
Base + 54	H27 Magnitude	% D,E A,B	.01 Volts/Scale Amps/Scale	0 – 10000 0 – 32,767 0 – 32,767	Magnitude of harmonic expressed as a percentage of the reference value, or as an absolute value.
Base + 55	H27 Angle	—	0.1 °	0 – 3,599 (-32,678 if N/A)	Angle of 27th harmonic referenced to fundamental Voltage A-N (4-wire) or Voltage A-B (3-wire).
Base + 56	H28 Magnitude	% D,E A,B	.01 Volts/Scale Amps/Scale	0 – 10000 0 – 32,767 0 – 32,767	Magnitude of harmonic expressed as a percentage of the reference value, or as an absolute value.
Base + 57	H28 Angle	—	0.1 °	0 – 3,599 (-32,678 if N/A)	Angle of 28th harmonic referenced to fundamental Voltage A-N (4-wire) or Voltage A-B (3-wire).
Base + 58	H29 Magnitude	% D,E A,B	.01 Volts/Scale Amps/Scale	0 – 10000 0 – 32,767 0 – 32,767	Magnitude of harmonic expressed as a percentage of the reference value, or as an absolute value.
Base + 59	H29 Angle	—	0.1 °	0 – 3,599 (-32,678 if N/A)	Angle of 29th harmonic referenced to fundamental Voltage A-N (4-wire) or Voltage A-B (3-wire).
Base + 60	H30 Magnitude	% D,E A,B	.01 Volts/Scale Amps/Scale	0 – 10000 0 – 32,767 0 – 32,767	Magnitude of harmonic expressed as a percentage of the reference value, or as an absolute value.
Base + 61	H30 Angle	—	0.1 °	0 – 3,599 (-32,678 if N/A)	Angle of 30th harmonic referenced to fundamental Voltage A-N (4-wire) or Voltage A-B (3-wire).
Base + 62	H31 Magnitude	% D,E A,B	.01 Volts/Scale Amps/Scale	0 – 10000 0 – 32,767 0 – 32,767	Magnitude of harmonic expressed as a percentage of the reference value, or as an absolute value.
Base + 63	H31 Angle	—	0.1 °	0 – 3,599 (-32,678 if N/A)	Angle of 31st harmonic referenced to fundamental Voltage A-N (4-wire) or Voltage A-B (3-wire).

Table A–9: Energy Registers (PM810 with PM810LOG)

Reg	Name	Units	Range	Notes
Energy Summary Usage				
16202	Energy, Real 3-Phase Total Usage Today	WH	(1)	
16205	Energy, Real 3-Phase Total Usage Yesterday	WH	(1)	
16208	Energy, Real 3-Phase Total Usage This Week	WH	(1)	
16211	Energy, Real 3-Phase Total Usage Last Week	WH	(1)	

Table A–9: Energy Registers (PM810 with PM810LOG)

Reg	Name	Units	Range	Notes
16214	Energy, Real 3-Phase Total Usage This Month	WH	(1)	
16217	Energy, Real 3-Phase Total Usage Last Month	WH	(1)	
16220	Energy, Apparent 3-Phase Total Usage Today	VAH	(1)	
16223	Energy, Apparent 3-Phase Total Usage Yesterday	VAH	(1)	
16226	Energy, Apparent 3-Phase Total Usage This Week	VAH	(1)	
16229	Energy, Apparent 3-Phase Total Usage Last Week	VAH	(1)	
16232	Energy, Apparent 3-Phase Total Usage This Month	VAH	(1)	
16235	Energy, Apparent 3-Phase Total Usage Last Month	VAH	(1)	
Energy Per Shift Usage (PM810 with PM810LOG)				
16238	Energy, Real 3-Phase Total Usage – First Shift - Today	WH		
16241	Energy, Real 3-Phase Total Usage - Second Shift - Today	WH	(1)	
16244	Energy, Real 3-Phase Total Usage - Third Shift - Today	WH	(1)	
16247	Energy, Real 3-Phase Total Usage - First Shift - Yesterday	WH	(1)	
16250	Energy, Real 3-Phase Total Usage - Second Shift - Yesterday	WH	(1)	
16253	Energy, Real 3-Phase Total Usage - Third Shift - Yesterday	WH	(1)	
16256	Energy, Real 3-Phase Total Usage - First Shift - This Week	WH	(1)	
16259	Energy, Real 3-Phase Total Usage - Second Shift - This Week	WH	(1)	
16262	Energy, Real 3-Phase Total Usage - Third Shift - This Week	WH	(1)	
16265	Energy, Real 3-Phase Total Usage - First Shift - Last Week	WH	(1)	
16268	Energy, Real 3-Phase Total Usage - Second Shift - Last Week	WH	(1)	
16271	Energy, Real 3-Phase Total Usage - Third Shift - Last Week	WH	(1)	
16274	Energy, Real 3-Phase Total Usage - First Shift - This Month	WH	(1)	
16277	Energy, Real 3-Phase Total Usage - Second Shift - This Month	WH	(1)	

Table A–9: Energy Registers (PM810 with PM810LOG)

Reg	Name	Units	Range	Notes
16280	Energy, Real 3-Phase Total Usage - Third Shift - This Month	WH	(1)	
16283	Energy, Real 3-Phase Total Usage - First Shift - Last Month	WH	(1)	
16286	Energy, Real 3-Phase Total Usage - Second Shift - Last Month	WH	(1)	
16289	Energy, Real 3-Phase Total Usage - Third Shift - Last Month	WH	(1)	
16292	Energy, Apparent 3-Phase Total Usage - First Shift - Today	VAH	(1)	
16295	Energy, Apparent 3-Phase Total Usage - Second Shift - Today	VAH	(1)	
16298	Energy, Apparent 3-Phase Total Usage - Third Shift - Today	VAH	(1)	
16301	Energy, Apparent 3-Phase Total Usage - First Shift - Yesterday	VAH	(1)	
16304	Energy, Apparent 3-Phase Total Usage - Second Shift - Yesterday	VAH	(1)	
16307	Energy, Apparent 3-Phase Total Usage - Third Shift - Yesterday	VAH	(1)	
16310	Energy, Apparent 3-Phase Total Usage - First Shift - This Week	VAH	(1)	
16313	Energy, Apparent 3-Phase Total Usage - Second Shift - This Week	VAH	(1)	
16316	Energy, Apparent 3-Phase Total Usage - Third Shift - This Week	VAH	(1)	
16319	Energy, Apparent 3-Phase Total Usage - First Shift - Last Week	VAH	(1)	
16322	Energy, Apparent 3-Phase Total Usage - Second Shift - Last Week	VAH	(1)	
16325	Energy, Apparent 3-Phase Total Usage - Third Shift - Last Week	VAH	(1)	
16328	Energy, Apparent 3-Phase Total Usage - First Shift - This Month	VAH	(1)	
16331	Energy, Apparent 3-Phase Total Usage - Second Shift - This Month	VAH	(1)	
16334	Energy, Apparent 3-Phase Total Usage - Third Shift - This Month	VAH	(1)	
16337	Energy, Apparent 3-Phase Total Usage - First Shift - Last Month	VAH	(1)	
16340	Energy, Apparent 3-Phase Total Usage - Second Shift - Last Month	VAH	(1)	
16343	Energy, Apparent 3-Phase Total Usage - Third Shift - Last Month	VAH	(1)	

Table A–9: Energy Registers (PM810 with PM810LOG)

Reg	Name	Units	Range	Notes
Energy Per Shift Cost (PM810 with PM810LOG)				
16348	Energy Cost - First Shift Today	Unit Code		Units associated with the cost per kWh.
16350	Energy Cost - Second Shift Today	Unit Code		Units associated with the cost per kWh.
16352	Energy Cost - Third Shift Today	Unit Code		Units associated with the cost per kWh.
16354	Energy Cost - First Shift Yesterday	Unit Code		Units associated with the cost per kWh.
16356	Energy Cost - Second Shift Yesterday	Unit Code		Units associated with the cost per kWh.
16358	Energy Cost - Third Shift Yesterday	Unit Code		Units associated with the cost per kWh.
16360	Energy Cost - First Shift This Week	Unit Code		Units associated with the cost per kWh.
16362	Energy Cost - Second Shift This Week	Unit Code		Units associated with the cost per kWh.
16364	Energy Cost - Third Shift This Week	Unit Code		Units associated with the cost per kWh.
16366	Energy Cost - First Shift Last Week	Unit Code		Units associated with the cost per kWh.
16368	Energy Cost - Second Shift Last Week	Unit Code		Units associated with the cost per kWh.
16370	Energy Cost - Third Shift Last Week	Unit Code		Units associated with the cost per kWh.
16372	Energy Cost - First Shift This Month	Unit Code		Units associated with the cost per kWh.
16374	Energy Cost - Second Shift This Month	Unit Code		Units associated with the cost per kWh.
16376	Energy Cost - Third Shift This Month	Unit Code		Units associated with the cost per kWh.
16378	Energy Cost - First Shift Last Month	Unit Code		Units associated with the cost per kWh.
16380	Energy Cost - Second Shift Last Month	Unit Code		Units associated with the cost per kWh.
16382	Energy Cost - Third Shift Last Month	Unit Code		Units associated with the cost per kWh.

APPENDIX B—USING THE COMMAND INTERFACE

Overview of the Command Interface

The power meter provides a command interface, which you can use to issue commands that perform various operations such as controlling relays. Table B–2 on page 181 lists the available commands. The command interface is located in memory at registers 8000–8149. Table B–1 lists the definitions for the registers.

Table B–1: Location of the command interface

Register	Description
8000	This is the register where you write the commands.
8001–8015	These are the registers where you write the parameters for a command. Commands can have up to 15 parameters associated with them.
8017	Command pointer. This register holds the register number where the last command is stored.
8018	Results pointer. This register holds the register number where the last command is stored.
8019	I/O data pointer. Use this register to point to data buffer registers where you can send additional data or return data.
8020–8149	These registers are for you (the user) to write information. Depending on which pointer places the information in the register, the register can contain status (from pointer 8017), results (from pointer 8018), or data (from pointer 8019). The registers will contain information such as whether the function is enabled or disabled, set to fill and hold, start and stop times, logging intervals, and so forth. By default, return data will start at 8020 unless you specify otherwise.

When registers 8017–8019 are set to zero, no values are returned. When any or all of these registers contain a value, the value in the register “points” to a target register, which contains the status, error code, or I/O data (depending on the command) when the command is executed. Figure B–1 shows how these registers work.

NOTE: You determine the register location where results will be written. Therefore, take care when assigning register values in the pointer registers; values may be corrupted when two commands use the same register.

Figure B-1: Command interface pointer registers

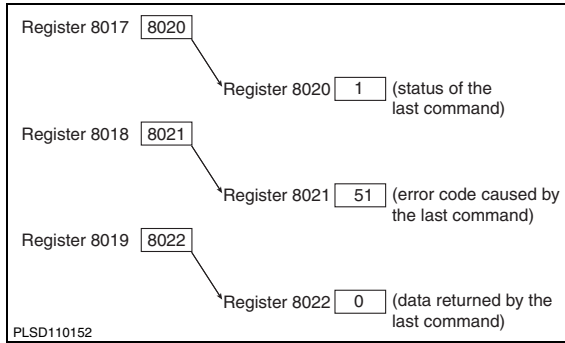

Issuing Commands

To issue commands using the command interface, follow these general steps:

1. Write the related parameter(s) to the command parameter registers 8001–15.
2. Write the command code to command interface register 8000.

If no parameters are associated with the command, then you need only to write the command code to register 8000. Table B–2 lists the command codes that can be written to the command interface into register 8000. Some commands have an associated registers where you write parameters for that command. For example, when you write the parameter 9999 to register 8001 and issue command code 3351, all relays will be energized if they are set up for external control.

Table B–2: Command Codes

Command Code	Command Parameter Register	Parameters	Description
1110	None	None	Causes soft reset of the unit (re-initializes the power meter).
1210	None	None	Clears the communications counters.
1310	8001 8002 8003 8004 8005 8006	Month Day Year Hour Minute Second	Sets the system date and time. Values for the registers are: Month (1–12) Day (1–31) Year (4-digit, for example 2000) Hour (Military time, for example 14 = 2:00pm) Minute (1–59) Second (1–59)
Relay Outputs			
3310	8001	Relay Output Number ①	Configures relay for external control.
3311	8001	Relay Output Number ①	Configures relay for internal control.
3320	8001	Relay Output Number ①	De-energizes designated relay.
3321	8001	Relay Output Number ①	Energizes designated relay.
3330	8001	Relay Output Number ①	Releases specified relay from latched condition.
① You must write to register 8001 the number that identifies which output you would like to use. To determine the identifying number, refer to “I/O Point Numbers” on page 185 for instructions.			
② Data buffer location (register 8019) is the pointer to the first register where data will be stored. By default, return data begins at register 8020, although you can use any of the registers from 8020–8149. <i>Take care when assigning pointers. Values may be corrupted if two commands are using the same register.</i>			

Table B-2: Command Codes

Command Code	Command Parameter Register	Parameters	Description
3340	8001	Relay Output Number ①	Releases specified relay from override control.
3341	8001	Relay Output Number ①	Places specified relay under override control.
3350	8001	9999	De-energizes all relays.
3351	8001	9999	Energizes all relays.
3361	8001	Relay Output Number ①	Resets operation counter for specified relay.
3362	8001	Relay Output Number ①	Resets the turn-on time for specified relay.
3363	8001	None	Resets the operation counter for all relays.
3364	8001	None	Resets the turn-on time for all relays.
3365	8001	Input Number ①	Resets the operation counter for specified input.
3366	8001	Input Number ①	Resets turn-on time for specified input.
3367	8001	None	Resets the operation counter for all inputs.
3368	8001	None	Resets turn-on time for all inputs.
3369	8001	None	Resets all counters and timers for all I/Os.
Resets			
1522	None	None	Resets the alarm history log.
4110	8001	0 = Present and previous months 1 = Present month 2 = Previous month	Resets min/max.
5110	None	None	Resets all demand registers.
5111	None	None	Resets current demand.
5113	None	None	Resets power demand.
5114	None	None	Resets input demand.
5115	None	None	Resets generic demand for first group of 10 quantities.
5210	None	None	Resets all min/max demand.
5211	None	None	Resets current min/max demand.
5213	None	None	Resets power min/max demand.
5214	None	None	Resets input min/max demand.
5215	None	None	Resets generic 1 min/max demand.
① You must write to register 8001 the number that identifies which output you would like to use. To determine the identifying number, refer to “I/O Point Numbers” on page 185 for instructions. ② Data buffer location (register 8019) is the pointer to the first register where data will be stored. By default, return data begins at register 8020, although you can use any of the registers from 8020–8149. <i>Take care when assigning pointers. Values may be corrupted if two commands are using the same register.</i>			

Table B–2: Command Codes

Command Code	Command Parameter Register	Parameters	Description
5910	8001	Bitmap	Start new demand interval. Bit 0 = Power Demand 1 = Current Demand 2 = Input Metering Demand 3 = Generic Demand Profile
6209	8019	I/O Data Pointer ②	Preset Accumulated Energies Requires the IO Data Pointer to point to registers where energy preset values are entered. All Accumulated energy values must be entered in the order in which they occur in registers 1700 to 1727.
6210	None	None	Clears all energies.
6211	None	None	Clears all accumulated energy values.
6212	None	None	Clears conditional energy values.
6213	None	None	Clears incremental energy values.
6214	None	None	Clears input metering accumulation.
6215	None	1 = IEEE 2 = IEC	Resets the following parameters to IEEE or IEC defaults: 1. Phase labels 2. Menu labels 3. Harmonic units 4. PF sign 5. THD denominator 6. Date Format
6320	None	None	Disables conditional energy accumulation.
6321	None	None	Enables conditional energy accumulation.
6910	None	None	Starts a new incremental energy interval.
Files			
7510	8001	1–3	Triggers data log entry. Bitmap where Bit 0 = Data Log 1, Bit 1 = Data Log 2, Bit 2 = Data Log 3, etc.
7511	8001	File Number	Triggers single data log entry.
<p>① You must write to register 8001 the number that identifies which output you would like to use. To determine the identifying number, refer to “I/O Point Numbers” on page 185 for instructions.</p> <p>② Data buffer location (register 8019) is the pointer to the first register where data will be stored. By default, return data begins at register 8020, although you can use any of the registers from 8020–8149. Take care when assigning pointers. Values may be corrupted if two commands are using the same register.</p>			

Table B-2: Command Codes

Command Code	Command Parameter Register	Parameters	Description
Setup			
9020	None	None	Enter into setup mode.
9021	8001	1 = Save 2 = Do not save	Exit setup mode and save all changes.
<p>① You must write to register 8001 the number that identifies which output you would like to use. To determine the identifying number, refer to “I/O Point Numbers” on page 185 for instructions.</p> <p>② Data buffer location (register 8019) is the pointer to the first register where data will be stored. By default, return data begins at register 8020, although you can use any of the registers from 8020–8149. <i>Take care when assigning pointers. Values may be corrupted if two commands are using the same register.</i></p>			

I/O Point Numbers

All inputs and outputs of the power meter have a reference number and a label that correspond to the position of that particular input or output.

- The reference number is used to manually control the input or output with the command interface.
- The label is the default identifier that identifies that same input or output. The label appears on the display, in SMS, and on the option card.
- See Table B–3 on page 185 for a complete list of I/O Point Numbers

Table B–3: I/O Point Numbers

Module	Standard I/O	PM8M22	PM8M26	PM8M2222	I/O Point Number
—	KY S1	—	—	—	1 2
A	—	A-R1 A-R2 A-S1 A-S2 A-S3 A-S4 A-S5 A-S6	A-R1 A-R2 A-S1 A-S2 A-S3 A-S4 A-S5 A-S6	A-R1 A-R2 A-S1 A-S2 A-AI1 A-AI2 A-AO1 A-AO2	3 4 5 6 7 8 9 10
B	—	B-R1 B-R2 B-S1 B-S2	B-R1 B-R2 B-S1 B-S2 B-S3 B-S4 B-S5 B-S6	B-R1 B-R2 B-S1 B-S2 B-AI1 B-AI2 B-AO1 B-AO2	11 12 13 14 15 16 17 18

Operating Outputs from the Command Interface

To operate an output from the command interface, first identify the relay using the *I/O point number*. Then, set the output to external control. For example, to energize output 1, write the commands as follows:

1. Write number 1 to register 8001.
2. Write command code 3310 to register 8000 to set the relay to external control.
3. Write command code 3321 to register 8000.

If you look in the “Relay Outputs” section of Table B–2 on page 181, you’ll see that command code 3310 sets the relay to external control and command code 3321 is listed as the command used to energize a relay. Command codes 3310–3381 are for use with inputs and outputs.

Using the Command Interface to Change Configuration Registers

You can also use the command interface to change values in selected metering-related registers, such as setting the time of day of the clock or resetting generic demand.

Two commands, 9020 and 9021, work together as part of the command interface procedure when you use it to change power meter configuration. You must first issue command 9020 to enter into setup mode, change the register, and then issue 9021 to save your changes and exit setup mode.

Only one setup session is allowed at a time. While in this mode, if the power meter detects more than two minutes of inactivity, that is, if you do not write any register values or press any buttons on the display, the power meter will timeout and restore the original configuration values. All changes will be lost. Also, if the power meter loses power or communications while in setup mode, your changes will be lost.

The general procedure for changing configuration registers using the command interface is as follows:

1. Issue command 9020 in register 8000 to enter into the setup mode.
2. Make changes to the appropriate register by writing the new value to that register. Perform register writes to all registers that you want to change. For instructions on reading and writing registers, see “View the Meter Information” on page 35 in **Chapter 3—Operation**.
3. To save the changes, write the value 1 to register 8001.
NOTE: Writing any other value except 1 to register 8001 lets you exit setup mode without saving your changes.
4. Issue command 9021 in register 8000 to initiate the save and reset the power meter.

For example, the procedure to change the demand interval for current is as follows:

1. Issue command code 9020 in register 8000.
2. Write the new demand interval to register 1801.
3. Write 1 to register 8001.
4. Issue command code 9021 in register 8000.

See **Appendix A—Power Meter Register List** on page 105 for those registers that require you to enter setup mode to make changes to the registers.

Conditional Energy

Power meter registers 1728–1744 are conditional energy registers.

Conditional energy can be controlled in one of two ways:

- Over the communications link, by writing commands to the power meter's command interface, or
- By a digital input—for example, conditional energy accumulates when the assigned digital input is on, but does not accumulate when the digital input is off.

The following procedures tell how to set up conditional energy for command interface control, and for digital input control. The procedures refer to register numbers and command codes. For a listing of power meter registers, see **Appendix A—Register List** on page 108. For a listing of command codes, see Table B–2 on page 181 in this chapter.

Command Interface Control

- **Set Control**—To *set control* of conditional energy to the command interface:
 1. Write command code 9020 to register 8000.
 2. In register 3227, set bit 6 to 1 (preserve other bits that are ON).
 3. Write 1 to register 8001.
 4. Write command code 9021 to register 8000.
- **Start**—To *start* conditional energy accumulation, write command code 6321 to register 8000.
- **Verify Setup**—To *verify proper setup*, read register 1794. The register should read 1, indicating conditional energy accumulation is ON.
- **Stop**—To *stop* conditional energy accumulation, write command code 6320 to register 8000.
- **Clear**—To *clear* all conditional energy registers (1728-1747), write command code 6212 to register 8000.

Digital Input Control

- **Set Control**—To configure conditional energy for digital input control:
 1. Write command code 9020 to register 8000.
 2. In register 3227, set bit 6 to 0 (preserve other bits that are ON).
 3. Configure the digital input that will drive conditional energy accumulation. For the appropriate digital input, write 3 to the *Base +9* register. See the digital input templates in Table A–3 on page 108 in **Appendix A—Power Meter Register List** on page 105.
 4. Write 1 to register 8001.
 5. Write command code 9021 to register 8000.
- **Clear**—To clear all conditional energy registers (1728–1747), write command code 6212 to register 8000.
- **Verify Setup**—To *verify proper setup*, read register 1794. The register should read 0 when the digital input is off, indicating that conditional energy accumulation is off. The register should read 1 when conditional energy accumulation is on.

Incremental Energy

The power meter's incremental energy feature allows you to define a start time, end time, and time interval for incremental energy accumulation. At the end of each incremental energy period, the following information is available:

- Wh IN during the last completed interval (reg. 1748–1750)
- VARh IN during the last completed interval (reg. 1751–1753)
- Wh OUT during the last completed interval (reg. 1754–1756)
- VARh OUT during the last completed interval (reg. 1757–1759)
- VAh during the last completed interval (reg. 1760–1762)
- Date/time of the last completed interval (reg. 1763–1765)
- Peak kW demand during the last completed interval (reg. 1940)
- Date/Time of Peak kW during the last interval (reg. 1941–1943)
- Peak kVAR demand during the last completed interval (reg. 1945)
- Date/Time of Peak kVAR during the last interval (reg. 1946–1948)
- Peak kVA demand during the last completed interval (reg. 1950)
- Date/Time of Peak kVA during the last interval (reg. 1951–1953)

The power meter can log the incremental energy data listed above. This logged data provides all the information needed to analyze energy and power usage against present or future utility rates. The information is especially useful for comparing different time-of-use rate structures.

When using the incremental energy feature, keep the following points in mind:

- Peak demands help minimize the size of the data log in cases of sliding or rolling demand. Shorter incremental energy periods make it easier to reconstruct a load profile analysis.
- Since the incremental energy registers are synchronized to the power meter clock, it is possible to log this data from multiple circuits and perform accurate totalizing.

Using Incremental Energy

Incremental energy accumulation begins at the specified start time and ends at the specified end time. When the start time arrives, a new incremental energy period begins. The start and end time are specified in minutes from midnight. For example:

Interval: 420 minutes (7 hours)

Start time: 480 minutes (8:00 a.m.)

End time = 1440 minutes (12:00 p.m.)

The first incremental energy calculation will be from 8:00 a.m. to 3:00 p.m. (7 hours) as illustrated in Figure B–2 on page 191. The next interval will be from 3:00 p.m. to 10:00 p.m., and the third interval will be from 10 p.m. to 12:00 p.m. because 12:00 p.m. is the specified end time. A new interval will begin on the next day at 8:00 a.m. Incremental energy accumulation will continue in this manner until the configuration is changed or a new interval is started by a remote master.

Figure B–2: Incremental energy example

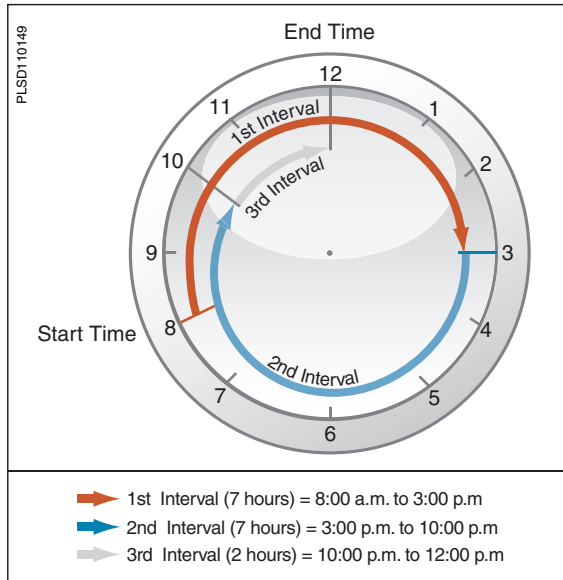

- **Set up**—To set up incremental energy:
 1. Write command code 9020 to register 8000.
 2. In register 3230, write a start time (in minutes-from-midnight).
 3. For example, 8:00 am is 480 minutes.
 4. In register 3231, write an end time (in minutes-from-midnight).
 5. Write the desired interval length, from 0–1440 minutes, to register 3229.
 6. If incremental energy will be controlled from a remote master, such as a programmable controller, write 0 to the register.
 7. Write 1 to register 8001.
 8. Write command code 9021 to register 8000.
- **Start**—To start a new incremental energy interval from a remote master, write command code 6910 to register 8000.

Setting Up Individual Harmonic Calculations

The PM810 with a PM810LOG can perform up to the 31st harmonic magnitude and angle calculations for each metered value and for each residual value. The harmonic magnitude for current and voltage can be formatted as either a percentage of the fundamental (THD), as a percentage of the rms values (thd), or rms. The harmonic magnitude and angles are stored in a set of registers: 13,200–14,608. During the time that the power meter is refreshing harmonic data, the power meter posts a value of 0 in register 3246. When the set of harmonic registers is updated with new data, the power meter posts a value of 1 in register 3246. The power meter can be configured to hold the values in these registers for up to 60 metering update cycles once the data processing is complete.

The power meter has three operating modes for harmonic data processing: disabled, magnitude only, and magnitude and angles. Because of the extra processing time necessary to perform these calculations, the factory default operating mode is magnitudes only.

To configure the harmonic data processing, write to the registers described in Table B-4:

Reg No.	Value	Description
3240	0, 1, 2	Harmonic processing; 0 = disabled 1 = magnitudes only enabled 2 = magnitudes and angles enabled
3241	0, 1, 2	Harmonic magnitude formatting for voltage; 0 = % of fundamental (default) 1 = % of rms 2 = rms
3242	0, 1, 2	Harmonic magnitude formatting for current; 0 = % of fundamental (default) 1 = % of rms 2 = rms
3243	10–60 seconds	This register shows the harmonics refresh interval (default is 30 seconds).
3244	0–60 seconds	This register shows the time remaining before the next harmonic data update.
3245	0,1	This register indicates whether harmonic data processing is complete: 0 = processing incomplete 1 = processing complete

Changing Scale Factors

The power meter stores instantaneous metering data in 16-bit single registers. A value held in each register must be an integer between –32,767 and +32,767. Because some values for metered current, voltage, and power readings fall outside this range, the power meter uses multipliers, or scale factors. This enables the power meter to extend the range of metered values that it can record.

The power meter stores these multipliers as scale factors. A scale factor is the multiplier expressed as a power of 10. For example, a multiplier of 10 is represented as a scale factor of 1, since $10^1=10$; a multiplier of 100 is represented as a scale factor of 2, since $10^2=100$.

You can change the default value of 1 to other values such as 10, 100, or 1,000. However, these scale factors are automatically selected when you set up the power meter, either from the display or by using SMS.

If the power meter displays “overflow” for any reading, change the scale factor to bring the reading back into a range that fits in the register. For example, because the register cannot store a number as large as 138,000, a 138 kV system requires a multiplier of 10. 138,000 is converted to 13,800 x 10. The power meter stores this value as 13,800 with a scale factor of 1 (because $10^1=10$).

Scale factors are arranged in scale groups. The abbreviated register list in **Appendix A—Power Meter Register List** on page 105 shows the scale group associated with each metered value.

You can use the command interface to change scale factors on a group of metered values. However, be aware of these important points if you choose to change scale factors:

NOTE:

- We **strongly recommend** that you do not change the default scale factors, which are automatically selected by POWERLOGIC hardware and software.
- When using custom software to read power meter data over the communications link, you must account for these scale factors. To correctly read any metered value with a scale factor other than 0, multiply the register value read by the appropriate power of 10.
- As with any change to basic meter setup, when you change a scale factor, all min/max and peak demand values should be reset.

Enabling Floating-point Registers

For each register in integer format, the power meter includes a duplicate set of registers in floating-point format. For an abbreviated list of floating-point registers, see Table A–7 on page 164. The floating point registers are disabled by default, but they can be turned ON by doing the following:

NOTE: See “Read and Write Registers” on page 36 for instructions on how to read and write registers.

1. Read register 11700 (Current Phase A in floating-point format). If floating-point registers are OFF, you will see -32,768.
2. Write command code 9020 to register 8000.
3. Write 1 in register 3248.
4. Write 1 to register 8001.
5. Write command code 9021 to register 8000.
6. Read register 11700. You will see a value other than -32,768, which indicates floating-point registers are ON.

NOTE: Values such as current phase A are not shown in floating-point format on the display even though floating-point registers are ON. To view floating-point values, read the floating-point registers using the display or SMS.

APPENDIX C—GLOSSARY

Terms

accumulated energy—energy can accumulate in either signed or unsigned (absolute) mode. In signed mode, the direction of power flow is considered and the accumulated energy magnitude may increase and decrease. In absolute mode, energy accumulates as a positive regardless of the power flow direction.

active alarm – an alarm that has been set up to trigger, when certain conditions are met, the execution of a task or notification. An icon in the upper-right corner of the meter indicates that an alarm is active (▲). See also *enabled alarm* and *disabled alarm*.

baud rate—specifies how fast data is transmitted across a network port.

block interval demand— power demand calculation method for a block of time and includes three ways to apply calculating to that block of time using the sliding block, fixed block, or rolling block method.

communications link—a chain of devices connected by a communications cable to a communications port.

current transformer (CT)—current transformer for current inputs.

demand—average value of a quantity, such as power, over a specified interval of time.

device address—defines where the power meter resides in the power monitoring system.

disabled alarm – an alarm which has been configured but which is currently

“turned off”; i.e, the alarm will not execute its associated task even when its conditions are met. See also *enabled alarm* and *active alarm*.

enabled alarm – an alarm that has been configured and “turned on” and will execute its associated task when its conditions are met. See also *disabled alarm* and *active alarm*.

event—the occurrence of an alarm condition, such as *Undervoltage Phase A*, configured in the power meter.

firmware—operating system within the power meter

fixed block—an interval selected from 1 to 60 minutes (in 1-minute increments). The power meter calculates and updates the demand at the end of each interval.

float—a 32-bit floating point value returned by a register (see Appendix A—Power Meter Register List on page 105). The upper 16-bits are in the lowest-numbered register pair. For example, in the register 4010/11, 4010 contains the upper 16-bits while 4011 contains the lower 16-bits.

frequency—number of cycles in one second.

line-to-line voltages—measurement of the rms line-to-line voltages of the circuit.

line-to-neutral voltages—measurement of the rms line-to-neutral voltages of the circuit.

maximum demand current—highest demand current measured in amperes since the last reset of demand.

maximum demand real power—highest demand real power measured since the last rest of demand.

maximum demand voltage—highest demand voltage measured since the last reset of demand voltage.

maximum demand (peak demand) — highest average load during a specific time interval.

maximum value—highest value recorded of the instantaneous quantity such as Phase A Current, Phase A Voltage, etc., since the last reset of the minimums and maximums.

minimum value—lowest value recorded of the instantaneous quantity such as Phase A Current, Phase A Voltage, etc., since the last reset of the minimums and maximums.

nominal—typical or average.

parity—refers to binary numbers sent over the communications link. An extra bit is added so that the number of ones in the binary number is either even or odd, depending on your configuration). Used to detect errors in the transmission of data.

partial interval demand—calculation of energy thus far in a present interval. Equal to energy accumulated thus far in the interval divided by the length of the complete interval.

phase currents (rms)—measurement in amperes of the rms current for each of the three phases of the circuit. See also *maximum value*.

phase rotation—phase rotations refers to the order in which the instantaneous values of the voltages or currents of the system reach their maximum positive values. Two phase rotations are possible: A-B-C or A-C-B.

potential transformer (PT)—also known as a voltage transformer

power factor (PF)—true power factor is the ratio of real power to apparent power using the complete harmonic content of real and apparent power. Calculated by dividing watts by volt amperes. Power factor is the difference between the total power your utility delivers and the portion of total power that does useful work. Power factor is the degree to which voltage and current to a load are out of phase.

real power—calculation of the real power (3-phase total and per-phase real power calculated) to obtain kilowatts.

rms—root mean square. Power meters are true rms sensing devices.

rolling block—a selected interval and subinterval that the power meter uses for demand calculation. The subinterval must divide evenly into the interval. Demand is updated at each subinterval, and the power meter displays the demand value for the last completed interval.

sag/swell—fluctuation (decreasing or increasing) in voltage or current in the electrical system being monitored. See also, voltage sag and voltage swell.

scale factor—multipliers that the power meter uses to make values fit into the register where information is stored.

safety extra low voltage (SELV)

circuit—a SELV circuit is expected to always be below a hazardous voltage level.

short integer—a signed 16-bit integer (see Register List on page 108).

sliding block—an interval selected from 1 to 60 minutes (in 1-minute increments). If the interval is between 1 and 15 minutes, the demand calculation updates every 15 seconds. If the interval is between 16 and 60 minutes, the demand calculation updates every 60 seconds. The power meter displays the demand value for the last completed interval.

SMS—see System Manager Software.

System Manager Software (SMS)—

software designed by POWERLOGIC for use in evaluating power monitoring and control data.

system type—a unique code assigned to each type of system wiring configuration of the power meter.

thermal demand—demand calculation based on thermal response.

Total Harmonic Distortion (THD or

thd)—indicates the degree to which the voltage or current signal is distorted in a circuit.

total power factor—see *power factor*.

true power factor—see *power factor*.

unsigned integer—an unsigned 16-bit integer (see Register List on page 89).

unsigned long integer—an unsigned 32-bit value returned by a register (see Register List on page 89). The upper 16-bits are in the lowest-numbered register pair. For example, in the register pair 4010

and 4011, 4010 contains the upper 16-bits while 4011 contains the lower 16-bits.

VAR—volt ampere reactive.

voltage sag—a brief decrease in effective voltage for up to one minute in duration.

voltage swell—increase in effective voltage for up to one minute in duration.

Abbreviations and Symbols

A —Ampere	F —Frequency
A IN —Analog Input	HARM —Harmonics
A OUT —Analog Output	HEX —Hexadecimal
ABSOL —Absolute Value	HIST —History
ACCUM —Accumulated	HZ —Hertz
ACTIV —Active	I —Current
ADDR —Power meter address	I/O —Input/Output
ADVAN —Advanced screen	IMAX —Current maximum demand
AMPS —Amperes	kVA —Kilovolt-Ampere
BARGR —Bargraph	kVAD —Kilovolt-Ampere demand
COINC —Demand values occurring at the same time as a peak demand value	kVAR —Kilovolt-Ampere reactive
COMMS —Communications	kVARD —Kilovolt-Ampere reactive demand
COND —Conditional Energy Control	kVARH —Kilovolt-Ampere reactive hour
CONTR —Contrast	kW —Kilowatt
CPT —Control Power Transformer	kWD —Kilowatt demand
CT —see <i>current transformer</i> on page 195	kWH —Kilowatthours
DEC —Decimal	kWH/P —Kilowatthours per pulse
D IN —Digital Input	kWMAX —Kilowatt maximum demand
DIAG —Diagnostic	LANG —Language
DISAB —Disabled	LOWER —Lower Limit
DISPL —Displacement	MAG —Magnitude
D OUT —Digital Output	MAINT —Maintenance screen
DMD —Demand	MAMP —Milliamperes
DO —Drop Out Limit	MB A7 —MODBUS ASCII 7 Bits
ENABL —Enabled	MB A8 —MODBUS ASCII 8 Bits
ENDOF —End of demand interval	MBRTU —MODBUS RTU
ENERG —Energy	MIN —Minimum

MINS —Minutes	RELAT —Relative value in %
MINMX —Minimum and maximum values	REG —Register Number
MSEC —Milliseconds	S —Apparent power
MVAh —Megavolt ampere hour	S.N. —Power meter serial number
MVARh —Megavolt ampere reactive hour	SCALE —see <i>scale factor</i> on page 196
MWh —Megawatt hour	Sd —Apparent power demand
NORM —Normal mode	SECON —Secondary
O.S. —Operating System (firmware version)	SEC —Secondary
P —Real power	Sh —Apparent Energy
PAR —Parity	SUB-I —Subinterval
PASSW —Password	SYS —System Manager™ software (SMS) system type (ID)
Pd —Real power demand	THD —Total Harmonic Distortion
PF —Power factor	U —Voltage line to line
Ph —Real energy	UNBAL —Unbalance
PM —Power meter	UPPER —Upper limit
PQS —Real, reactive, apparent power	V —Voltage
PQsd —Real, reactive, apparent power demand	VAh —Volt amp hour
PR —Alarm Priority	VARh —Volt amp reactive hour
PRIM —Primary	VMAX —Maximum voltage
PT —Number of voltage connections (see <i>potential transformer</i> on page 196)	VMIN —Minimum voltage
PU —Pick Up Limit	Wh —Watt-hour
PULSE —Pulse output mode	
PWR —Power	
Q —Reactive power	
Qd —Reactive power demand	
Qh —Reactive energy	
R.S. —Firmware reset system version	

INDEX

A

- accumulate energy
 - signed or unsigned more 54
- active alarm log
 - registers 152–154
- address
 - device address 104
- alarm backlight
 - setup 29
- alarm history
 - registers 154–155
- alarm log
 - description 91
- alarms
 - abbreviated names defined 84
 - alarm conditions 73, 83
 - alarm numbers 84
 - alarm types 84, 85
 - creating data log entries 95
 - custom alarms 74
 - digital 74
 - introduction to 73
 - priorities 77
 - scaling alarm setpoints 81, 83
 - setpoints 75
 - setup 23
 - standard 74
 - test registers 84
 - types 78
- analog input
 - set up 70
- analog output 71

B

- bar graph
 - setup 29
- baud rate 104
- billing log 95
 - configure log interval 96
 - data calculation 95
 - register list 96
- block interval demand method 45

- box contents 8

C

- calculating
 - duration of an event 76
 - watthours per pulse 69
 - changing
 - scale factors 81
 - clock
 - view 37
 - clock synchronized demand 47
 - command interface
 - changing configuration registers 187
 - issuing commands 181
 - operating outputs 186
 - overview 179
 - registers for 179
 - scale factors 193
 - command synchronized demand 47
 - communications
 - problems with PC communication 104
 - setup 17, 18
 - conditional energy
 - controlling from the command interface 188
 - register for 188
 - contacting technical support 101
 - controlling relays 64
 - correlation sequence number 76
 - CT
 - setup 20
 - custom
 - alarms 74
- D**
- data log 93
 - clearing the logs 94
 - storage in power meter 100
 - date
 - setup 19
 - view 37

- default password 16
 - demand
 - current 48
 - generic 50
 - predicted 48
 - thermal 48
 - demand current calculation 48
 - demand power
 - calculation 45
 - demand power calculation methods 47
 - demand readings 44
 - demand current 48
 - demand power calculation methods 45
 - generic demand 50
 - peak demand 49
 - predicted demand 48
 - reset 32
 - demand synch pulse method 63
 - diagnostics
 - password 25
 - digital alarms 74
 - digital inputs 61
 - digital input alarms 74
 - operating modes 62
 - receiving a synch pulse 47
 - Digital Inputs screen 61
 - displacement power factor described 58
 - display
 - menu overview 14
 - operating 13
 - dropout and pickup setpoints 75
- E**
- energy
 - conditional energy registers 188
 - password 25
 - energy readings 53, 54
 - reactive accumulated 54
 - reset 32
 - event log

calculating duration of event 76
correlation sequence number 76
data storage 91

F
features 9
firmware 10
fixed block 45
floating-point registers enabling 105

G
generic demand calculation 50
getting technical support 101

H
harmonic setting up individual calculations 192
values 58
health status 36
heartbeat LED 103
high priority alarms 77
Hi-Pot testing 99

I
I/O position numbers 185
setup 24
incremental energy 189
interval 49
using with the command interface 190
incremental energy interval setup 27
initialize power meter 31
input digital input 61
input synchronized demand 47
input/output setup 24
inputs accepting pulse from another meter 47
digital input alarms 74
digital inputs operating modes 62
issuing commands 181

K
KY 68
calculating watt hours per pulse 69

L
labels for inputs and outputs 185
language changing 101
setup 20, 101

LED
heartbeat 103
lock resets setup 28
logs 89
alarm log 91
billing log 95
clearing data logs 94
data log 93
maintenance log 91
low priority alarms 77

M
maintenance logs 91
maintenance icon 103
stored log values 91
medium priority alarms 77
megger testing 99
memory power meter memory 100
menu 14
meter information 35
metered values demand readings 44
energy readings 53
real-time readings 39
minimum/maximum password 25
minimum/maximum values reset 33
mode reset 33

N
no priority alarms 77
nonvolatile memory 100

O
on-board logs 89
operating time reset 34
operating time threshold set up 25
operation 13
problems with the power meter 103
using the command interface 179
outputs analog 71
overvoltage alarm type 78

P
password default 16
diagnostics 25
energy 25
minimum/maximum 25
setup 25
peak demand calculation 49
phase loss alarm type for current 79
alarm type for voltage 79
phase reversal alarm type 80
phase rotation setup 26
pickups and dropouts scale factors 81
setpoints 75

PLC
synchronizing demand with 47
power analysis values 58, 59
power demand configuration setup 30
power factor 58 min/max conventions 42
storage of 106
power meter accessories 7
described 3
firmware 10
hardware 4
initialization 31
instrumentation summary 3

- models 7
- reset 31
- setup 16
- with display
 - parts 4, 6
 - without display
 - parts 5
- predicted demand calculation 48
- problems
 - see troubleshooting 102
- protocols
 - register addressing
 - convention 105
- PT
 - setup 21
- R**
- read registers 36
- readings
 - demand 44
- real-time readings 39
 - min/max values 40
- recording
 - data in logs 93
- registers
 - 1s metering
 - current 108
 - frequency 111
 - power 109
 - power factor 109–111
 - voltage 108
 - addressing conventions 105
 - alarm log
 - active 152–154
 - history 154–155
 - alarms
 - counters 156–159
 - digital 162
 - standard speed 159–162
 - system status 156
 - template (1) 163
 - billing log 96
 - communications
 - RS485 138
 - current/voltage configuration 130
 - demand
 - current channels 122–
 - 123
 - current configuration and data 117–118
 - generic configuration and data 120–121
 - generic group 1 channels 126–127
 - input metering channels 125–126
 - input metering configuration and data 119–120
 - miscellaneous configuration and data 121
 - power channels 123–125
 - power configuration and data 118–119
 - energy 116–117
 - cost per shift 178
 - per shift 176–177
 - usage summary 175–176
 - floating-point 105
 - 1s metering
 - current 164
 - energy 165–169
 - frequency 165
 - power 164–165
 - power factor 165
 - voltage 164
 - for conditional energy 188
 - fundamental magnitudes and angles
 - current 112
 - sequence components 113
 - input/output
 - analog input template 149–150
 - analog output template 151–152
 - auxiliary 139–144
 - discrete input template 145–146
 - discrete output template 146–148
 - option modules 144–145
 - standard modules 144–145
 - metering configuration and status
 - basic 131–132
 - diagnostics 134–137
 - harmonics 133
 - resets 137
 - minimum/maximum
 - present group 1 114
 - present group 2 115
 - previous group 1 114–115
 - previous group 2 115
 - phase extremes 127
 - power factor format 106
 - power quality
 - THD 111–112
 - read 36
 - spectral components
 - harmonic 170–171
 - template
 - data 171–175
 - system configuration 127–129
 - templates
 - alarms (1) 163
 - analog input 149–150
 - analog output 151–152
 - discrete input 145–146
 - discrete output 146–148
 - minimum/maximum 115
 - spectral components 171–175
 - using the command interface 187
 - write 36
- relay operating modes
 - absolute kVARh pulse 66
 - absolute kWh pulse 66
 - end of demand interval 65
 - kVAh pulse 66
 - kVAR out pulse 66
 - kVARh in pulse 66
 - kWh in pulse 66
 - kWh out pulse 66
 - latched 65
 - normal 64
 - timed 65
- relays
 - internal or external control of

64
operating using command interface 181
reset
 accumulated operating time 34
 demand readings 32
 energy readings 32
 minimum/maximum values 33
 mode 33
 power meter 31
resets
 of peak demand values 49
 values in generic demand profile 50
reverse power alarm type 80
rolling block 45
route statement 104
S
scale factors 81
 changing scale factors 193
 scale groups 81
 scaling alarm setpoints 83
scale groups 81
set up
 analog outputs 71
 custom alarms 74
 individual harmonic calculations 192
setup 16
 alarm backlight 29
 alarms 23
 bar graph 29
 communications 17, 18
 CT 20
 date 19
 I/O 24
 incremental energy interval 27
 input/output 24
 language 20, 101
 lock resets 28
 password 25
 phase rotation 26
 power demand configuration 30
 PT 21

 system type 21, 22
 THD calculation 27
 time 19
 VAR/PF convention 28
sliding block 45
SMS
 power meters supported by 2
 using SMS 2
standard alarms 74
synchronized demand
 clock 47
 command 47
 input 47
synchronizing
 demand interval to internal clock 47
 demand interval to multiple meters 47
 to PLC command 47
System Manager Software 3
 see SMS.
system type
 setup 21, 22

T
technical support 101
testing
 dielectric (hi-pot) test 99
 megger test 99
THD
 setup 27
 thd calculation method 58
thermal demand method 48
time
 setup 19
 view 37
total harmonic distortion 58
types of alarms 85

U
unbalance current alarm type 79
unbalance voltage alarm type 79
undervoltage alarm type 78

V
VAR
 sign conventions 43

VAR/PF convention
 setup 28
view clock 37
view date and time 37
viewing meter information 35, 37
W
watthours
 calculating watthours per KYZ pulse 69
wiring
 troubleshooting 104
write registers 36

Schneider Electric
Power Monitoring and Control
295 Tech Park Drive, Suite 100
La Vergne, TN, 37086
1 (615) 287-3400
www.schneider-electric.com
www.powerlogic.com

This product must be installed, connected, and used in compliance with prevailing standards and/or installation regulations.

As standards, specifications, and designs change from time to time, please ask for confirmation of the information given in this publication.

Este producto deberá instalarse, conectarse y utilizarse en conformidad con las normas y/o los reglamentos de instalación vigentes.

Debido a la evolución constante de las normas y del material, es recomendable solicitar previamente confirmación de las características y dimensiones.

Ce produit doit être installé, raccordé et utilisé conformément aux normes et/ou aux règlements d'installation en vigueur.

En raison de l'évolution des normes et du matériel, les caractéristiques et cotes d'encombrement données ne nous engagent qu'après confirmation par nos services.

Publishing: Square D Company PMO

Production: Square D Company PMO